

Radio-Electronics®

FOR MEN WITH IDEAS IN ELECTRONICS

ALL ABOUT ACTIVE FILTERS
Don Lancaster Tells It

INSIDE THE VARIOMATRIX
How Sansui Does It

BUILD THIS ELECTRONIC STOPWATCH

COMPUTER ARITHMETIC
How It Works

PLUS

Appliance Clinic
Servicing Record Changers

Bob Scott's Technical Topics
R-E's Replacement Transistor Guide



BERNSBACK PUBLICATION

The Timesaver!



Latest, all solid state version of the sensational signal circuit analyzing timesaver originated by Castle.

Invaluable for locating the break in the tuner and i.f. signal chain or analyzing agc system defects in tube TV receivers . . . essential for speedy location of signal circuit defects in modular IC, solid state and hybrid TV receivers.

A NEW APPROACH to agc system analyzing!

Permits signal injection after the agc controlled stages to simplify testing for agc defects.

- Works with any 40MHz receiver . . . color or black and white . . . solid state, tube or hybrid.
- High level, low impedance output furnishes signal usable at input of final i.f. stage.
- Special output circuit works equally well into first i.f. input of late model, link coupled systems and older, low "C" bandpass coupled systems.
- Antenna input and i.f. output electrically isolated; no "hot" chassis hazards.
- No need to disconnect supply leads from suspected tuner being tested. Substitutes the VHF tuner and tests the UHF tuner.
- Tunes all 12 VHF channels, has preset (memory) fine tuning on all channels.
- Higher overall gain than previous models with wide range gain reduction control of 60db.
- Completely self contained and battery operated, uses popular batteries available everywhere. Simple battery replacement; battery compartment in rear of custom molded case.
- Reduced current consumption extends battery life to as much as double that of previous models. Bright LED indicator warns when unit is ON.
- Use on the bench or in the home . . . anywhere.
- Comes complete with extension cables, batteries and instructions.

Specifications

Inputs:	300 ohms balanced VHF antenna terminals, electrically isolated; 75 ohms 40 MHz amplifier (Ch.#1) RCA phono jack, electrically isolated.
Sensitivity:	30 microvolts, Input signal handling capability; over 100,000 microvolts.
Output:	40 MHz TV i.f.: bandwidth 6 MHz, "Mastermatchcoupler" output circuit with matched cable to furnish usable signal for all input circuits, Termination is RCA phono jack, electrically isolated.
Tuning Range:	All 12 VHF TV channels, plus Ch.#1 40 MHz amplifier position for testing UHF tuners. High stability of 40 MHz amplifier permits two Mk.IV Subbers to be cascaded for high level 40 MHz output signal from any VHF channel.
Tuning:	Preset (memory) fine tuning.
Gain Control:	Gain reduction 60 db.
Power supply:	18 volts. Uses two 9v transistor batteries.
Size & Weight:	6.5"x 6.5"x 3.25" exclusive of control knobs and handle, 1.5 lbs complete with batteries.
Accessories:	"Mastermatchcoupler" output cable with RCA phono Jack termination, "Mastermatchcoupler" output cable with alligator clip terminations, UHF tuner test cable.

TV TUNER SUBBERTM Mark IV net \$45.95

Contact your distributor



CASTLE TV TUNER SERVICE, INC.

5715 N. Western Ave., Chicago, Illinois 60645 • Phone: (312) - 561-6354

In Canada: Len Finkler Co., Ontario

Circle 1 on reader service card

FREE...demonstration lesson to prove that you can learn TV servicing at home.

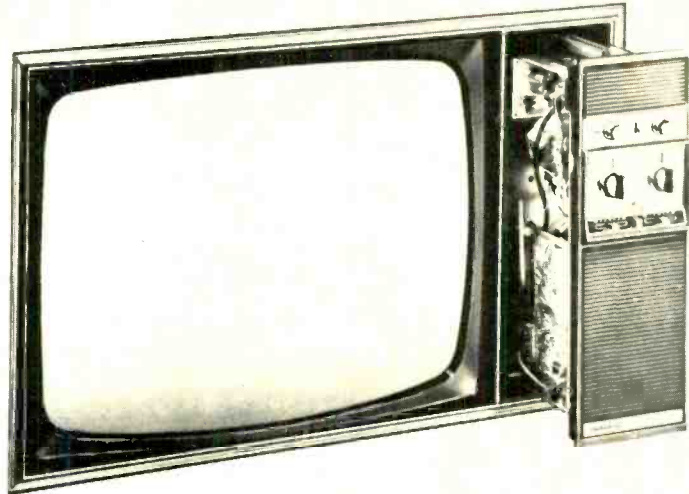

Practice on a new 25" MOTOROLA QUASAR II® chassis.

TV Servicing is a satisfying career . . . and the pay is great. Qualified men are needed now to maintain the 93 million sets in U.S. homes. And prospects for the future are even brighter.

Now . . . here's an opportunity for you to prove to yourself that **you** can learn TV Servicing . . . at home, in your spare time. ICS, the world's most experienced home-study school, will send you a **FREE** Demonstration Lesson (complete with sample questions) if you will merely fill out the coupon below and mail it to us.

In addition to your free demonstration lesson, we'll send you . . . also **FREE** . . . a brochure that describes the 25" (diagonally measured screen) MOTOROLA QUASAR II® Color TV chassis that we include in our TV Service Training Program.

This chassis with automatic fine tuning control is ideal for training purposes because it combines solid state devices with vacuum tubes to give you both kinds of practical experience.

Credit towards a Certified Electronic Technician (C.E.T.) rating will be granted by the National Electronics Association to ICS students upon completion of the ICS Career Program in TV Service/Repair.

ICS

International Correspondence Schools
Since 1890
School of Electronics
Scranton, Pa. 18515

Approved for Veterans' Training, Eligible students use coupon address for service from Institution under the Guaranteed Student Loan Program. Accredited Member National Home Study Council, Canadian ICS Canadian, Ltd. In Hawaii: 931 University Ave., Honolulu, Hawaii 96813

All parts carry Motorola's two year replacement guarantee!

The QUASAR II chassis comes to you in three basic sub-assemblies . . . NOT AS A KIT . . . because we want you to learn how to **repair** TV sets, not build them.

Our free literature also describes the fully assembled test equipment you receive such as the Deluxe 5" Solid State Oscilloscope, the tools and the learn-by-doing kits, all of the finest quality.

And we're going to tell you about eight other career opportunities in Electronics and the ICS Career Programs that can help prepare you for them. All you've got to do is mail the coupon. **SEND IT TODAY!**

ICS School of Electronics
International Correspondence Schools
Scranton, Pa. 18515

YES, I want you to mail to me without obligation, the FREE DEMONSTRATION LESSON and complete literature on the career program checked below. (Please check one.)

- | | |
|--|--|
| <input type="checkbox"/> Color TV Servicing & Repair | <input type="checkbox"/> FCC Licensing |
| <input type="checkbox"/> Computer Maintenance | <input type="checkbox"/> Communications/
Broadcasting |
| <input type="checkbox"/> CATV/MATV Technician | <input type="checkbox"/> Hi-Fi Sound Systems |
| <input type="checkbox"/> Telephony | <input type="checkbox"/> Industrial Electronics |
| <input type="checkbox"/> Electrician | |

AA625S

Name _____ Age _____

Address _____

City _____

State _____ Zip _____

We've expanded our replacement guide to over 75,000 listings.

That's 34,000 more than our last ECG™ Semiconductor Replacement Guide. And more replacements than you'll find in any other guide.

We've also made our new ECG 212E guide more useful by including our industrial replacement types so you can locate commercial components with the same ease as consumer components.

You'll also find more imported types listed and the proper ECG replacement cross referenced.

Both the ECG 212E guide and the ECG replacement semiconductors are available at your local Sylvania distributor.

And we've made sure that the parts are just as available as the guide.

After all, when you work hard to produce the biggest and the best replacement guide, you also work hard to make sure the parts are available when needed.

Sylvania Electronic Components, 100 First Ave., Waltham, Mass. 02154

GTE SYLVANIA

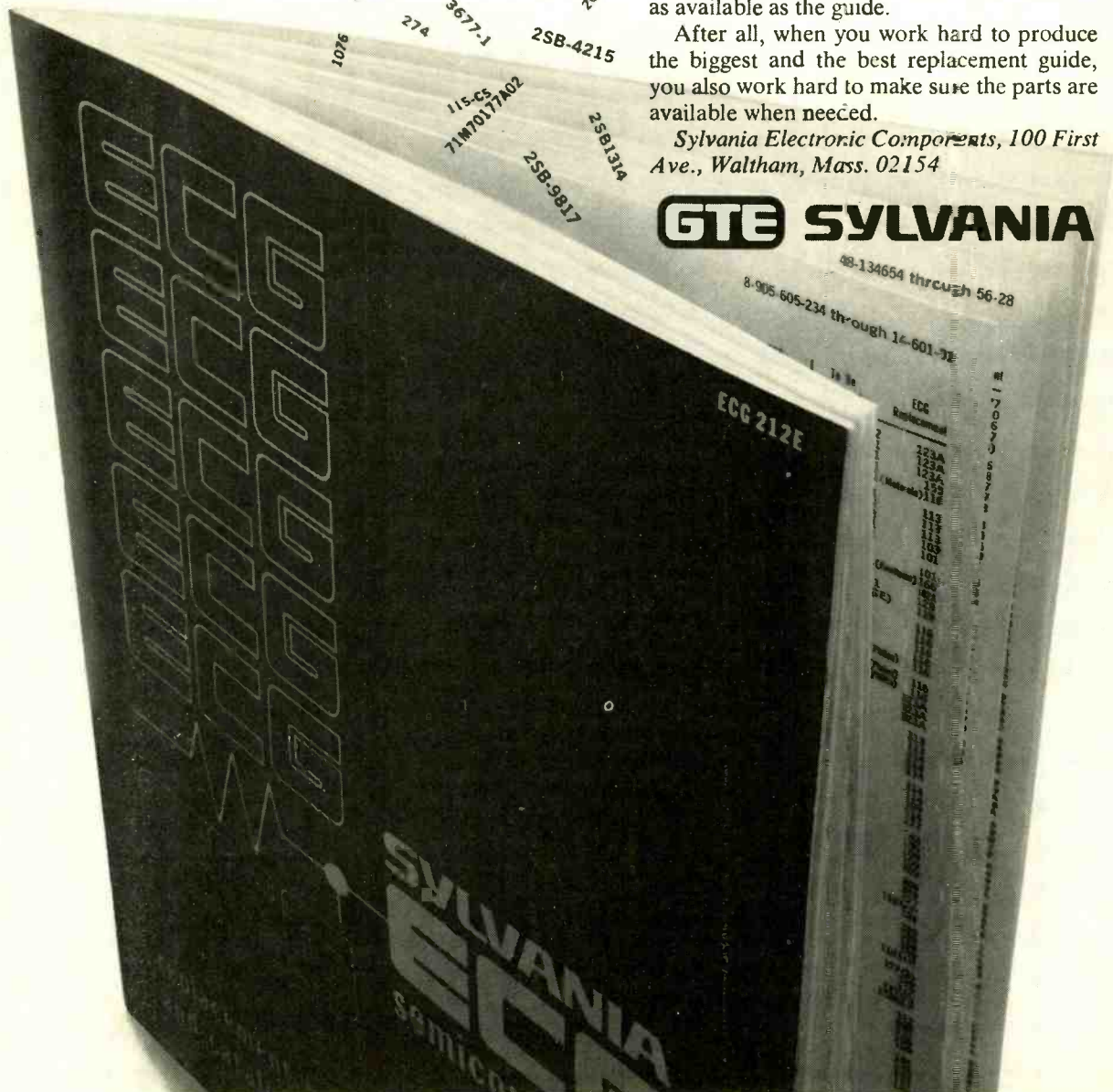

Radio-Electronics

FOR MEN WITH IDEAS IN ELECTRONICS

More than 65 years of electronics publishing

NOVEMBER 1973

BUILD THIS ONE

- 31 **Hand-Held Digital Stopwatch**
Your choice of 3, 4, 5, or 6 digits. Times; tells time; can be remotely triggered on and off. *by Bill Green*

4-CHANNEL HIGH-FIDELITY AUDIO

- 35 **Inside The Sansui 4-Channel QS Variomatrix**
Another step forward in the continuing development of the matrix system for reproduction of 4-channel records. *by Leonard Feldman*
- 51 **Servicing Record Changers**
21 basic steps that take many of the headaches out of record changer repairs. *by Elliot S. Kanter*
- 61 **Equipment Report**
Lafayette LR-4000, 4-channel receiver

GENERAL ELECTRONICS

- 4 **Looking Ahead**
Tomorrow's news today. *by David Lachenbruch*
- 26 **Appliance Clinic**
Electronic matches. *by Jack Darr*
- 42 **All About Active Filters**
They offer several important advantages, but do have drawbacks too. Make sure you know how to use them effectively. *by Don Lancaster*
- 45 **Careers In Electronics**
Countless opportunities are open to the High-School graduate. Here is a close-up look at several of these choices. *by James A. Gupton*
- 58 **Understanding Computer Arithmetic**
How do electronic circuits solve problems? Here's an article that tells what happens. *by H. Edward Roberts*

TELEVISION

- 62 **Step-By-Step Troubleshooting**
Foreign-brand agc systems can spell trouble. Get to know them before they turn up on your bench. *by Stan Prentiss*
- 72 **Service Clinic**
The color is a mess. *by Jack Darr*
- 80 **Reader Questions**
R-E's Service Editor helps solve your problems.

SOLID-STATE ELECTRONICS

- 48 **Technical Topics**
Four practical solid-state circuits we think you'll enjoy. *by Robert F. Scott*
- 68 **R-E's Transistor Replacement Guide**
Two more pages of replacement transistor types. *compiled by Robert and Elizabeth Scott*

TEST EQUIPMENT

- 28 **Equipment Report**
Data Precision Digital Multimeter
- 61 **Equipment Report**
Jud Williams Model A Curve Tracer

DEPARTMENTS

- | | |
|---------------------------|---------------------------|
| 95 Books | 84 New Products |
| 96 Technotes | 92 Next Month |
| 16 Letters | 111 Reader Service |
| 6 New & Timely | 98 Try This |
| 89 New Literature | |



VARIOMATRIX means better 4-channel sound from your record player. Learn how this recent development operates. . . . see page 35

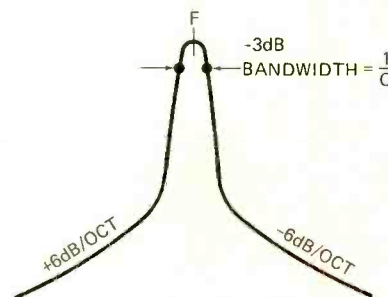

ACTIVE FILTERS make sharp rolloffs both possible and practical. Learn how they work and what they will and won't do. . . . see page 42

Hugo Gernsback (1884-1967)
founder
M. Harvey Gernsback, editor-in-chief
and publisher
Larry Steckler, CET, editor
Robert F. Scott, W2PWG CET, technical editor
Jack Darr, CET, service editor
I. Queen, editorial associate
Leonard Feldman, contributing high-fidelity editor
David Lachenbruch, contributing editor
Barbara Schwartz, editorial assistant
Vincent P. Cicenia, production manager
Sarah Martin, production assistant
H. Matysko, circulation
Arline R. Fishman, advertising coordinator

Cover photograph by Walter Herstatt
Cover design by Louis E. Rubsam

Radio-Electronics is indexed in *Applied Science & Technology Index and Readers Guide to Periodical Literature*.



Radio-Electronics, November 1973, Vol. 44, No. 11. Published monthly by Gernsback Publications, Inc., 200 Park Avenue South, New York City 10003. Second-class postage paid at New York, N. Y. and additional mailing office. One-year subscription rate: U.S.A., U.S. possessions and Canada, \$7. Pan-American countries, \$8. Other countries, \$8.50. Single copies 80¢. ©1973 by Gernsback Publications, Inc. All rights reserved. Printed in U.S.A.

Subscription Service: Mail all subscription orders, changes, correspondence and Postmaster Notices of undelivered copies (Form 3579) to Radio-Electronics Subscription Service, Boulder, Colo. 80302.

A stamped self-addressed envelope must accompany all submitted manuscripts and/or artwork or photographs if their return is desired should they be rejected. We disclaim any responsibility for the loss or damage of manuscripts and/or artwork or photographs while in our possession or otherwise.

As a service to readers, Radio-Electronics publishes available plans or information relating to newsworthy products, techniques and scientific and technological developments. Because of possible variances in the quality and condition of materials and workmanship used by readers, Radio-Electronics disclaims any responsibility for the safe and proper functioning of reader-built projects based upon or from plans or information published in this magazine.

looking ahead

Another videodisc

Paris, France—New home videodisc systems are cropping up with the same regularity that videotape systems were proposed a couple of years ago. The latest to surface is a long-rumored laser-optical system developed by Thomson-CSF, the audio-visual branch of the huge French electrical-electronics firm, Thomson-Brandt. Thomson has indicated that it is nearly ready to think about commercialization of its system and has staged demonstrations for television manufacturers of the world, including American set makers.

Thomson hasn't yet released details on its system, but it belongs to the same family as videodiscs demonstrated by Philips of Holland and MCA Disco-Vision of Universal City, Cal. The latter two systems, as previously described in this space, bounce laser light from reflective discs spinning at a speed synchronized with television's frame rate. The Thomson system differs in that it uses a transparent disc, and the scanning laser light shines through the disc. Thomson has given no date for public showing or marketing, but is making a strong effort to have its own system adopted as the world standard.

In addition to the three laser-optical systems, two other techniques are employed in videodisc systems announced so far: (1) Mechanical pressure pickup with flexible disc, used in the Telefunken-Decca-Teldec German-British system now in pilot production. (2) Electrostatic, or capacitance, system which is understood to be employed by RCA. All of the systems are designed to play at least 20 minutes of color per 12-

inch record, except the Teldec mechanical system, which gives 10 minutes' playing time on an eight-inch disc.

'Video card'

Details about another simple and potentially low-cost home color TV playback system have been released by Digital Recording Corp., Scarborough, N.Y. Working with Battelle Development Co., DRC says it has succeeded in compressing 30 minutes of monochrome programming onto a 5-by-7-inch piece of film, and hopes to have a color version with stereo sound soon. The recording is made by converting the video signal to digital pulses which switch a laser beam on and off. Scanned vertically across the photographic plate, the laser makes a series of dots. The system records only the differences between successive pictures, thereby making possible high-density recording in a small area.

Playback equipment directs a switched laser to the film by a scanning wheel containing four lenses, revolving at 3,600 rpm. The video cards are duplicated by standard photographic processes. DRC says home playback attachments for color TV should cost about \$200, and processing of a 30-minute video card about 50 cents, exclusive of the cost of the program, of course.

Trouble in videoland

Although dreams of home video systems continue to be rosy, the one company already in the business of providing color VTR's to the consumer is finding the going rough. Cartridge Television Inc., which has been manufacturing home videotape

decks for Admiral, Sears, Teledyne and Montgomery Ward, has filed a petition of involuntary bankruptcy in New York federal court. Whether it's just growing pains for a new product or a basic consumer reluctance to accept videoplayers can't yet be determined. However, at press time, the prospects appeared good for the infusion of new capital and resumption of operations.

More Chromacolors

Another major name has left the color picture tube manufacturing business. Philco-Ford has sold its tube plant in Lansdale, Pa. to Zenith, which will expand it and convert it to the manufacture of its patented Chromacolor negative-matrix tube. Philco, which has been in the picture tube manufacturing business virtually since the start of television, thus joins Admiral and Motorola as TV makers who have left the tube business. The remaining U.S.-based color tube makers are General Electric, RCA, Sylvania, Westinghouse and Zenith—recently joined by Sony, which is establishing Trinitron manufacturing facilities in California, near its new American television plant.

Quick color

Color TV warmup time has been a real problem in the past, and it has been tackled by keeping tube filaments warm when the set is off, at the cost of extra electrical power to the set owner. With the advent of solid-state sets, the picture tube has become the weak link, and for quick-on performance its heater is the only one left to be preheated. Now Philips has developed a picture tube which provides a quick picture with-

out preheating. The trick is a very small coiled cathode which reaches operating temperature in five seconds, as opposed to 15 to 30 seconds in the standard tube. The tube offers the added advantage of a saving of about 20% in power consumption when the set is turned on, in addition to the economy of eliminating preheating. American tube makers may be expected to emulate the Philips quick-heating cathode design.

Television's junk heap

The American public has junked more than 99,000,000 television sets since the start of the TV era. Nevertheless, more than half of the TVs ever sold—105,300,000—are still in use. These facts are brought to light in an analysis made by Sylvania's Research Department and published in the 1973-74 edition of *Television Factbook*. The tabulation shows that more than 205 million television sets have been produced in the United States since the start of post-war telecasting.

Surprisingly, the Sylvania research shows that some 1,600,000 color TV sets joined the junkpile last year and were replaced. This means that close to 20 percent of color sales last year were replacements. In 1973, it's expected that 2,200,000 color sets will be scrapped and that 24 percent of the sales will be replacements for old color sets rather than first color sets introduced into homes. The survey shows that the public now owns 62,800,000 monochrome sets and 42,500,000 color sets. Sylvania estimates that the average life of a black-and-white or color set is about the same—10 years.

by DAVID LACHENBRUCH
CONTRIBUTING EDITOR

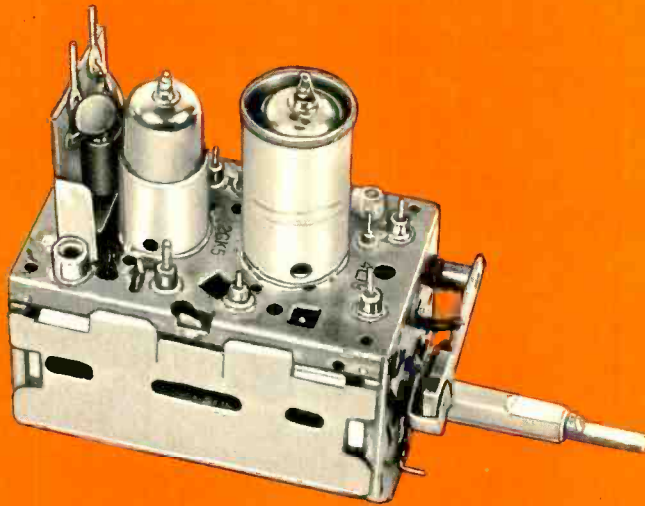

\$9.95

ALL PARTS INCLUDED

except tubes and transistors

ONE YEAR GUARANTEE

TUNER SERVICE CORPORATION

PROVIDES YOU WITH A COMPLETE SERVICE FOR ALL YOUR TELEVISION TUNER REQUIREMENTS.

REPAIR

VHF Or UHF Any Type \$9.95.
UHF/VHF Combo \$15.00.

In this price all parts are included. Tubes, transistors, diodes, and nuvistors are charged extra.

Fast efficient service at our conveniently located service centers. This price does not cover mutilated tuners.

All tuners are cleaned ultrasonically, repaired, realigned and air tested.

REPLACE

Universal Replacement Tuner \$9.95.

This price buys you a complete new tuner built specifically by SARKES TARZIAN INC. for this purpose.

All shafts have a maximum length of 10" which can be cut to 1½".

Specify heater type parallel and series 450mA or 600mA.

CUSTOMIZE

Customized tuners are available at a cost of only \$15.95. (With trade-in \$13.95)

Send in your original tuner for comparison purposes to:

TUNER SERVICE CORPORATION FACTORY-SUPERVISED TUNER SERVICE

Backed by the largest tuner manufacturer in the U.S.—SARKES TARZIAN, Inc.

HEADQUARTERS	BLOOMINGTON, INDIANA 47401	537 South Walnut St.	Tel: 812-332-7251
ARIZONA	TUCSON, ARIZONA 85713	1528 S. 6th St.	Tel: 602-791-9243 (P.O. Box 4534)
CALIFORNIA	BURLINGAME, CALIFORNIA 94010	1324 Marsten Road	Tel: 415-347-5728
CALIFORNIA	MODESTO, CALIFORNIA 95351	123 Phoenix Ave.	Tel: 209-521-8051
CALIFORNIA	NORTH HOLLYWOOD, CALIF. 91601	18654 Magnolia Blvd.	Tel: 213-769-2720
FLORIDA	TAMPA, FLORIDA 33606	1505 Cypress St.	Tel: 813-253-0324
GEORGIA	ATLANTA, GEORGIA 30310	938 Gordon St., S.W.	Tel: 404-758-2232
ILLINOIS	CHICAGO, ILLINOIS 60621	741 W. 55th St.	Tel: 312-873-5555-6-7
INDIANA	INDIANAPOLIS, IND. 46204	817 N. Pennsylvania St.	Tel: 317-632-3493
INDIANA	HAMMOND, INDIANA 46323	6833 Grand Ave.	Tel: 219-845-2676
KENTUCKY	LOUISVILLE, KENTUCKY 40208	2920 Taylor Blvd.	Tel: 502-634-3334
MARYLAND	BALTIMORE, MD. 21215	5505 Reisterstown Rd.	Tel: 301-338-1186 (P.O. Box 2624)
MISSOURI	ST. LOUIS, MO. 63132	10530 Page Ave.	Tel: 314-429-0633
NEVADA	LAS VEGAS, NEVADA 89108	305 Vegas Drive	Tel: 702-648-1450
NEW JERSEY	JERSEY CITY, NEW JERSEY 07307	547-49 Tonnele Ave.	Tel: 201-792-3730 (On U.S. Highway 1 & 9)
NEW JERSEY	TRENTON, NEW JERSEY 08638	901 N. Olden Ave.	Tel: 609-393-0999
OHIO	CINCINNATI, OHIO 45216	7450 Vine St.	Tel: 513-821-5080
OHIO	CLEVELAND, OHIO 44109	4597 Pearl Road	Tel: 216-741-2314
OHIO	TOLEDO, OHIO 43624	119 N. Erie St.	Tel: 419-243-6733
OREGON	PORTLAND, OREGON 97210	1732 N.W. 25th Ave.	Tel: 503-222-9059
TENNESSEE	GREENVILLE, TENNESSEE 37743	1215 Snapps Ferry Rd.	Tel: 615-639-8451
TENNESSEE	MEMPHIS, TENNESSEE 38114	1703 Lamar Ave.	Tel: 901-278-4484
TEXAS	DALLAS, TEXAS 75213	11540 Garland Rd.	Tel: 214-327-8413
VIRGINIA	NORFOLK, VIRGINIA 23502	4538 Princess Ann Road ..	Tel: 703-855-2518

Franchises available—Contact headquarters.

Circle 3 on reader service card



**WATCH US
GROW**

Spacecraft electrical system to be computer controlled

NASA is now testing and evaluating a new system for controlling electrical power in advanced spacecraft. In present aerospace electrical systems, heavy wire feeders lead from the power source to cockpit switches and circuit breakers, to permit the flight crew to control the electrical loads. In the new approach, called Automatically Controlled Electrical System (ACES) by its developer, the Westinghouse Aerospace Division, the feeders run from the generator to various load centers. These are located in electrical "centers of gravity" for various parts of the craft, and are so placed as to minimize feeder lengths. Power is switched at these points by solid-state controllers remotely controlled from the cockpit. Thus reliability is increased and feeder voltage drops and conductor weight are minimized.

The remote controllers are hybrid switching circuits. The dc controller con-



NASA ENGINEER T. D. JEFFCOAT punches a combination of load and power for a simulation run into the data entry panel in the cockpit test setup at NASA's Manned Spacecraft Center. The five consoles in the background simulate the electrical loads for the nose, electronics, air lock, intervehicular activity and tall compartments of a hypothetical space shuttle vehicle.

sists of a power transistor which is the actual power switching element, current and voltage sensors, and a control circuit for on, off, trip, and voltage limiting.

The ac controller has an SCR power switch, voltage and current sensors and a control that provides a shaped trip characteristic as well as on-off control.

All electrical loads are controlled and sequenced with logic programmed into the distribution control center, a general purpose digital computer. Signals from the control switches and sensors are transmitted to it on multiplexed data buses, logic equations are performed and control signals sent back to turn the power controllers on or off. Indication signals from the remote points are also processed and transmitted to the craft status indicators. The display panel shows system status and also provides for manual control.

ACES automatically sheds loads to prevent overloading the power sources if a portion of the generating capacity is lost. Up to 12 priority programming schedules can be selected as required.

Two of the systems have been supplied for testing to NASA by Westinghouse.

Deaf child learns from teddy bear

Teddy, a stuffed brown bear, is an educator, whose eyes beam at the success of his pupils. He is also the pet of 3-year-old Nicola Stapleton, of Bedfordshire, England, who is at the same time Teddy's pupil.

Nicola, born practically deaf, has some remnants of hearing. "She can hear, with the help of powerful amplifiers, over a limited frequency range," explains her teacher, Mrs. Gwyneth Cobb of the Bedfordshire Deaf Children's Society. "But when she begins to talk she cannot hear her own voice. How was I to put it over to children like Nicola that they are making sounds?"

Teddy was the answer. Rigged up by a couple of fellow Society workers, he is equipped with a microphone and an amplifier that supplies output signals to small lamps in his eyes. When Nicola makes a sound, Teddy's eyes light up with pleasure.

"Teddy was a success from the word go," says Mrs. Cobb. "Nicola first hugged the bear, then prodded and poked it. At 2½ years, she was in the gurgling stage, where she makes sounds from pure excitement. When Teddy's eyes lit up for the first time she was baffled, but in no time at all she came to realize that it was sound coming from

her that worked the eyes."

Teddy's eyes flash an authentic red, like those of other bears, which is why they may not look too bright in the black-and-white photo. But why is he



NICOLA AND TEDDY, WITH MRS. COBB

wearing the headphones? Nicola is fitted permanently with ultra-powerful earphones, but sound from the amplifier and headphones is more controllable. "Nicola has to use them, so I put them on Teddy," says Mrs. Cobb. "Then Nicola wants to wear them, too."

Gerald F. Rice winner of latest Gernsback award

A resident of Jamaica, NY, Gerald F. Rice, is the recipient of the Hugo Gernsback Scholarship Award for 1973. This award is a \$125 grant given each year to a student in each of nine leading home-study electronics schools. The candidates for the award are selected by the schools, and Mr. Rice was selected on the basis of an excellent academic record with the school, his deep involvement with electronics studies, and scholarship need due to partial disability.

A sheet-metal worker, he was disabled by an industrial accident in 1970. Although four severed fingers on his left hand were sewn back into place and 50 per cent of the capability of the hand restored, he was unable to continue at his trade.

His father had been an RCA employee, and had sparked an interest in electronics in his son, who now decided to turn to that field. Enrolling in Home Entertainment Systems course of the Bell

(continued on page 12)

Our tests show that JERROLD Super Vu-Finders And Paralogs Outperform All Others

- MORE GAIN & FLATTER RESPONSE
- RUGGED AND EASY TO INSTALL
- ELECTRICALLY GROUNDING

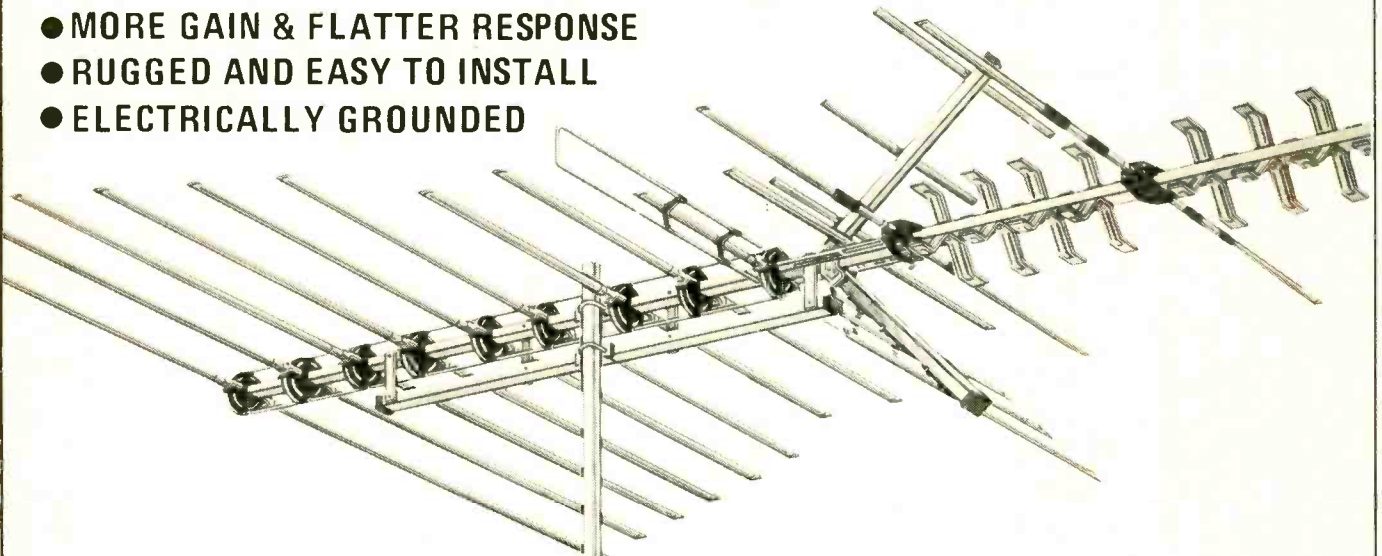

WE WANT YOUR PROFESSIONAL OPINION.



(TOOLS
NOT
INCLUDED)

FREE! HEAVY DUTY LEATHER TOOL POUCH

Last year we offered NFL Coffee Mugs for trying Jerrald antennas. This year it's Tool Pouches. Why do we make these offers? Because we know that once you stack Jerrald antennas up against the antennas you are using now, you'll switch to Jerrald. Hundreds of dealers switched last year.

If you're a professional antenna installer, you owe it to yourself to make this evaluation.

FOR EVALUATING ANY SUPERVU-FINDER OR PARALOG 300 PLUS.

JERROLD ELECTRONICS CORPORATION



P. O. Box 350, Dept. DSD, 200 Witmer Road, Horsham, Pa. 19044

Please send me a free Tool Pouch. Enclosed is an instruction sheet from the following Super VU-Finder antenna.

(model) _____

1 Before trying the Super VU-Finder, I was using the following antenna:
(make) _____ (model) _____

2 In my opinion the Super VU-Finder is: BETTER WORSE
because: _____

3 Comments: _____

NAME _____

COMPANY NAME _____

ADDRESS _____

CITY _____ STATE _____ ZIP _____

COUPON MUST BE POSTMARKED BEFORE DEC. 31, 1973

Circle 4 on reader service card

NOVEMBER 1973 • RADIO-ELECTRONICS 7

NOW train at home with NRI to be a Computer or Digital Technician—no other program is so complete in digital logic, computer operation and programming.

ANOTHER



FIRST

Your own digital computer included at no extra cost

This may very well be the most unique educational aid ever developed for home training—a *real* digital computer you build yourself and use to learn organization, operation, trouble shooting and programming. This remarkable training aid performs the same functions as bigger commercial computers. One of ten training kits you receive in the new NRI Complete Computer Electronics course.



NRI FIRSTS make learning Electronics fast and fascinating—give you priceless confidence

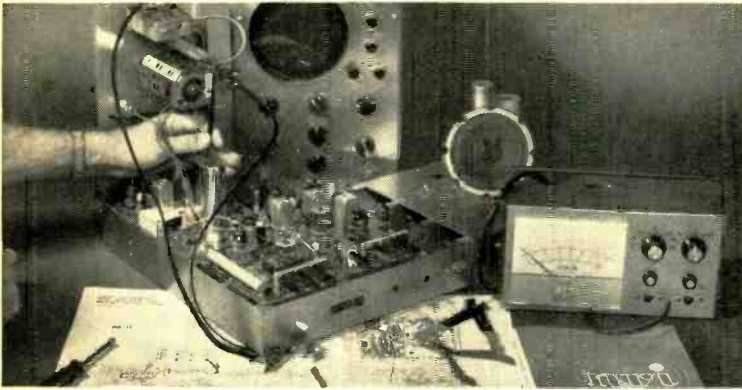

FIRST to give you Color TV training equipment engineered specifically for education—built to fit NRI instructional material, not a do-it-yourself hobby kit. The end product is a superb Color TV receiver that will give you and your family years of pleasure. You “open up and explore” the functions of each color circuit as you build.

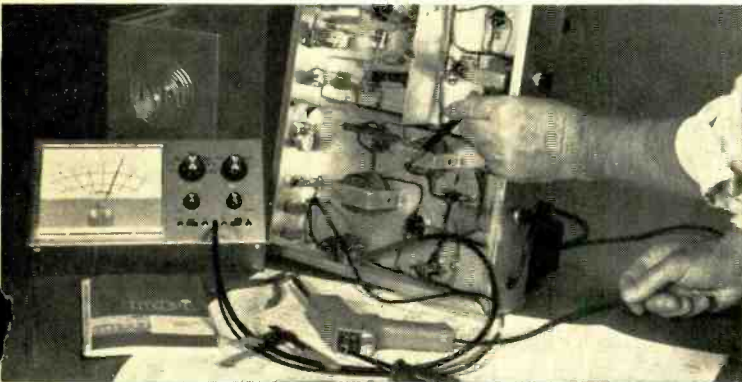

FIRST to give you true-to-life experiences as a Communications Technician. Every fascinating step you take in NRI Communications training, including circuit analysis of your own 25-watt, phone/cw transmitter, is engineered to help you prove theory and later apply it on the job. Studio equipment operation and trouble shooting become a matter of easily remembered logic.

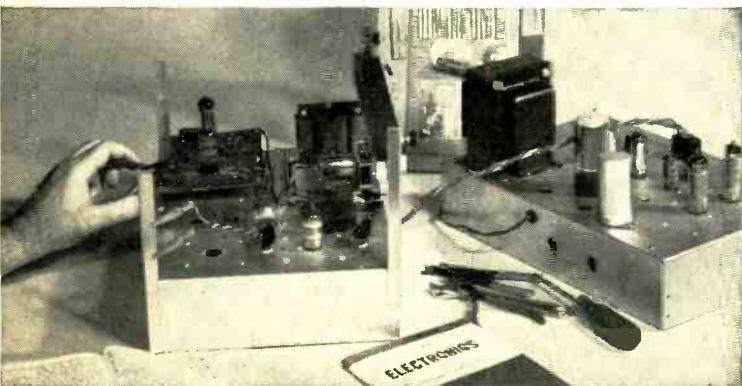

FIRST to give you completely specialized training kits engineered for business, industrial and military Electronics Technology. Shown is your own training center in solid-state motor control and analog computer servo-mechanisms. Telemetering circuits, solid-state multivibrators and the latest types of integrated circuits are included in your course.

There is so much to tell you about this latest “first” in home training from NRI, you must fill in and mail the postage-free card today to get the full story of the Complete Computer Electronics course and the amazing digital computer you build and use as you learn.

Planned from the start to include specially designed training equipment in the pioneering NRI tradition, this exceptional new course succeeds in combining kits with NRI “bite-sized” texts to give you an easy-to-understand educational package. But, unlike other home training, this is not a general electronics course. Lessons have been specifically written to stress computer repair. You perform a hundred experiments, you build hundreds of circuits. Included are over 50 modern, dual-in-line TTL integrated circuits you use in the construction of your computer. You use professional test equipment. In addition to your digital computer, you build and use your own solid-state voltohmmeter and oscilloscope. Because you work with your hands as well as your head, your training is as much *fun* as it is education.

Train with the leader—NRI

As it has in other fields of home-study Electronics training, NRI has taken the leadership in computer training because the “Computer Age” continues to leap ahead. Qualified men are urgently needed, not only as digital technicians and field service representatives, but also for work on data acquisition systems in such fascinating fields as telemetry, meteorology and pollution control. Office equipment and test instruments also demand the skills of the digital technician. Like other NRI courses, this exciting new program can give you the priceless confidence you seek to walk into a technician’s job and know just what to do and how to do it. Mail the postage-free card for the FREE NRI Catalog. No obligation. No salesman will call. NATIONAL RADIO INSTITUTE, Washington, D.C. 20016.

GET FACTS ABOUT GI BILL

If you have served since January 31, 1955, or are in service now, check GI line on postage-free card or in coupon.

If postcard has been used, mail this coupon



NATIONAL RADIO INSTITUTE
Washington, D.C. 20016 3-113

Please send me your FREE NRI CATALOG with details about new Complete Computer Electronics training.

Name _____ Age _____

Address _____

City _____ State _____ Zip _____

Check here for facts on GI Bill

ACCREDITED MEMBER NATIONAL HOME STUDY COUNCIL

& Howell Schools, with the help of the Veterans' Administration, which is assisting in tuition to the extent of 90 per cent, he is now working five hours a day



on the home study course, and reading chemistry, physics and math to increase his knowledge. Once he obtains employment, he plans to continue his study—toward a degree in electronics technology.

Radio pioneer dies at 81

Jay G. Gilfillan, co-founder with his brother, the late S. W. Gilfillan, of the Gilfillan radio and radar company, died in Los Angeles July 18. He was 81 years old.

Founded in 1912, the Gilfillan company originally extracted precious metals such as platinum and iridium. In the 1920's, it became one of the most prominent radio manufacturers of the country, being especially popular on the West Coast.

During World War II, the Gilfillan brothers, working with the Massachusetts Institute of Technology, built important ground-controlled-approach (GCA) radar aircraft landing systems. Gilfillan became a part of the ITT system in 1964.

Mr. Gilfillan is survived by his wife, two children and five grandchildren.

Pay CATV demonstrated in two Pennsylvania cities

"Channel 100," a form of pay cable TV, may soon make its debut in many of those cable TV systems whose franchises permit making special charges for given programs. Demonstrated recently over CATV systems in Harrisburg and Easton, the new approach promises current movies, blacked-out sporting events, concerts, plays and other live entertainment, as well as instructional programs such as home study courses in foreign

languages, speed reading, guitar playing, etc.

The channel space needed for Channel 100 would be leased from the cables by Optical Systems Corp. of Los Angeles, developers of the system. Material would be supplied the CATV system by microwave, video tape or movie film, or combinations of these.

Payment will be handled with a "black box" into which the customer inserts previously purchased credit-card-size tickets. The Channel 100 program then appears on his TV screen. Present plans for current movies are that a single ticket would entitle the customer or members of his family to view the movie as many times as they wish during the week that it runs. Cost would vary from \$2.25 for an individual week to \$1.50 on a "season pass" basis. Prices for special programs like sporting events or concerts would vary according to the event.

Micro-units for Microwaves

These two photographs are a dramatic demonstration of the miniaturization achieved in solid-state construction. The top is of a few microwave



diode chips, made by Raytheon in Waltham, Mass. The ridgy surface on which the units are photographed is the tip of an index finger!

The other photo is of a Siemens 3-GHz power transistor, mounted on a thin-film circuit measuring only 0.6 x 0.6 millimeter! The small dark bands at left are resistors, used to keep the current



load-uniform to each emitter strip.

The Raytheon devices are put together with the help of microscopes—the Siemens photograph owes its quality to the fact that an *Autoscan* electron scanning microscope was used to make the photograph, giving the impression of a much larger object photographed by ordinary means.

New light-carrying fiber has only 5 dB loss per km

A high-efficiency optical fiber just developed by Bell Laboratories scientists makes it possible to fabricate an efficient light-carrying fiber from a single material. Up to the present, optical fibers have been made with two materials: a center core—glass or liquid—and a surrounding outer cladding. Fibers made with different glass materials may have contained impurities that caused transmission losses.

Three Bell scientists, S. E. Miller, E. J. Marcatili and P. Kaiser, selected a glass that showed a very low transmission loss as an unclad fiber. Then they developed a unique configuration that made it possible to form the glass into an optical fiber without any additional materials. One design has three components, as shown in the photograph: an outer tube, a transverse partition across the tube that acts as a supporting plate for the center rod.

The assembly is then drawn into a hair-thin fiber. In drawing, all parts are brought into close contact, but the contact is not intimate enough to permit escape of light from the rod, even though plate, rod and tube are made of the same type of glass.

Home TV receivers are becoming more useful

Two devices, both using the screen of an ordinary TV set as an output, are being introduced by Cassette Sciences, of Los Angeles.

The first, a movie film player, connects to the TV by clipping two wires to the antenna terminals. It will accommodate a 12,000-foot film. Playing time for super-8 film will be 60 minutes, for 16-mm film, 33 minutes. The 8-mm version is expected this Fall, the 16-mm unit next Spring. Price for either will be around \$500.

The computer terminal connects to the telephone to contact the local Cas-

(continued on page 14)

NEW LOW PRICES ON WINEGARD® QUALITY ACCESSORIES!

set couplers—2-way splitters—band separators—matching transformers ^{reduced up to} **31%**

Why buy "second line" TV components when you can buy the best . . . Winegard engineered-and-built for less and get the same high quality and performance?

Check with your distributor for new low pricing on these items.

Reduced 14%

CS-285 300 OHM V-U BAND SEPARATOR—High quality, low loss Band Separator for adapting single 300 ohm download to separate 300 ohm VHF and UHF antenna connections of TV set. Perfect match insures perfect color and black and white reception.



Reduced 31%

CC-482 82 CH. 4-SET COUPLER—Deluxe low loss coupler connects four TV-FM sets to a single 300 ohm download. Efficient coupler circuit provides a maximum amount of signal to each receiver. Specially designed for color, black and white and stereo.



Reduced 31%

CS-387 75 OHM V-U-FM BAND SEPARATOR—Band Separator for making connection between 75 ohm coaxial download and separate 300 ohm antenna terminals of TV set and FM receiver. Features latest printed circuit design for low loss, high isolation and perfect match. Excellent for quality color and FM stereo reception. Connector included.



Reduced 28%

CC-33 82 CH. 2-SET COUPLER—Inexpensive coupler for connecting two TV or FM sets to a single 300 ohm download. Features handy no-strip terminals for easy connection.



Reduced 18%

CS-380 300 OHM V-U-FM BAND SEPARATOR—Latest Band Separator design adapts 300 ohm download to separate VHF and UHF antenna terminals of TV set and provides FM stereo thru handy no-strip screw terminals. Unique printed circuit design has extremely low loss, excellent match and high isolation for perfect color and FM stereo.



Reduced 22%

CS-175 75 OHM V-U BAND SEPARATOR—Quality 75 ohm Band Separator for attaching coaxial cable to separate 300 ohm antenna terminals of TV set. Features printed circuit and latest circuitry for low insertion loss and perfect color transmission. Connector included.



Reduced 26%

CC-282 82 CH. 2-SET COUPLER—Efficient 300 ohm coupler connects two TV-FM sets to a single 300 ohm download. Input and output connections are handy no-strip type for easy installation. Quality circuitry insures perfect color and black and white reception.



Low Price!

LS-27 82 CH. LINE SPLITTER—High quality line splitter for dividing a single 75 ohm coaxial cable into two trunk lines. Indoor type with transformer network features excellent match. Connectors included.



NEW

Low Price!

T-12BLK 82 CH. MATCHING TRANSFORMER—Compact indoor Matching Transformer for attaching coaxial cable to 300 ohm antenna terminals of TV or FM receiver. Packed 6 per poly bag, 8 bags per master carton. Connectors included.

NEW



WINEGARD
ANTENNA SYSTEMS

3000 KIRKWOOD ST. • BURLINGTON, IOWA 52601

Circle 80 on reader service card

NOVEMBER 1973 • RADIO-ELECTRONICS 13

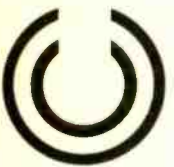

SERVICEMASTER

International

The Money Making line.

- The most complete range of consumer and industrial receiving tubes in the world — over 2000 domestic and foreign types
- Complete range of replacement Semiconductors.
- Discounted to give you higher profit margins
- Quality your customers can depend on

For complete details, call (516) 293-1500.

Or write,
International Components Corporation
 10 Daniel Street,
 Farmingdale,
 New York 11735.

new & timely (continued from page 12)

sette Services time-sharing computer, and to the TV as a read-out device. Up to 16 lines of information, with 64 characters per line, can be placed on the TV screen.

Cassette Sciences expects that by the end of the year, when the machine will reach the market, some 20 programs—ranging from chess to calculus—will be available. As with the movie player, target retail price is \$500.

FAA initiates new era in air traffic control

Computer-driven radar displays showing the identity and three-dimensional positioning of aircraft went into action at the Los Angeles Air Route Traffic Control Center in the middle of June. Controllers in the Center will spend some months learning how to use the new equipment before the facility becomes fully operational late this year.

The new system reads out the aircraft's identity, range, bearing, altitude and other flight information directly on the controller's radar scope. The current system reads out only range and bearing.



80 YEARS OF RECORDING HISTORY was presented to the visitors at the annual Audio Engineering Society meeting in Los Angeles. More than 40 pieces of equipment, old records, photos and other material were put on display by John T. Mullin, professional recorder development manager of 3M's Minicom division. Mullin owns about 90 per cent of the equipment. At the right, one of the first pieces of electrical recording apparatus, as supplied by Bell Labs to Columbia and Victor in 1925. At left is one of the first recording microphones, and at the extreme left, part of a Berliner "Trade Mark" phonograph that dates back to about 1895. R-E

Radio-Electronics is published by Gernsback Publications, Inc. 200 Park Ave. S. New York, N.Y. 10003 (212) 777-6400
 President: M. Harvey Gernsback
 Secretary: Bertina Baer

ADVERTISING SALES

EAST
 Stanley Levitan, Eastern Sales Mgr.
 Radio-Electronics
 200 Park Ave. South
 New York, N.Y. 10003
 (212) 777-6400

MIDWEST/Texas/Arkansas/Okla.
 Ralph J. Bergen
 The Ralph J. Bergen Co.
 6319 N. Central Ave.
 Chicago, Ill. 60646
 (312) 792-3646

PACIFIC COAST/Mountain States
 Jay Eisenberg
 J.E. Publishers Representative Co.,
 8732 Sunset Blvd., 4th Floor
 Los Angeles, Calif. 90069
 (213) 659-3810
 420 Market St.,
 San Francisco, Calif. 94111
 (415) 981-4527

SOUTHEAST
 E. Lucian Neff Associates
 25 Castle Harbor Isle,
 Fort Lauderdale, Florida 33308
 (305) 566-5656

MOVING?

Don't miss a single copy of **Radio-Electronics**. Give us:

Six weeks' notice

Your old address and zip code

Your new address and zip code

ATTACH LABEL HERE

name (please print)

address

city state zip code

Mail to: Radio-Electronics
 SUBSCRIPTION DEPT., BOULDER, COLO.
 80302

IF YOU HAVE STEREO, YOU ALREADY OWN HALF A 4-CHANNEL SYSTEM! ADD THE 2nd HALF FOR 164.95. BY REALISTIC®.

Save 17.45 off our "each" prices for everything you need
to move up to true quadraphonic sound!

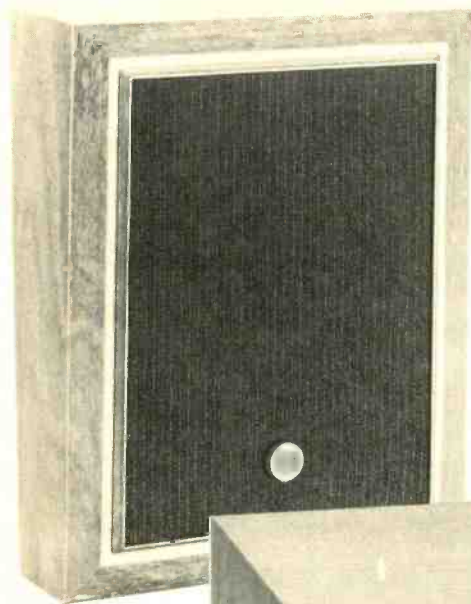

Baffle/Speakers
With Walnut
Enclosures



24-Watt Stereo
Amplifier



SQ-II 4-Channel
Decoder

SQ-II Decoder Alone 39⁹⁵

Your stereo components are ready and waiting for easy updating to 4-channel. Our SQ-II Decoder unscrambles all matrixed 4-channel records, tapes and FM broadcasts and even gives a 4-channel effect to regular stereo. Add it, and our SA-175B Amplifier

plus two deluxe Baffle/Speakers to your system, and hear sound from front and rear, left and right—the way you hear actual "live" music. Simple hookup, no internal rewiring. Get a demonstration at any of 2000 Radio Shack stores in all 50 states!

Now Playing at Over 2000 Stores in ALL 50 States

Price may vary at individual stores.



FREE '74 CATALOG 283
AT YOUR NEARBY STORE OR
MAIL THIS COUPON

180 Pages . . . Full Color! Hi-Fi, CB, Kits,
Recorders, Antennas, Parts, More!

PLEASE
PRINT
CLEARLY

Name _____ Apt. # _____

Street _____

City _____ State _____ ZIP

REALISTIC®

by

Radio Shack®

and ALLIED RADIO STORES

A TANDY CORPORATION COMPANY

P.O. Box 1052, Fort Worth, Texas 76107

Circle 81 on reader service card

NOVEMBER 1973 • RADIO-ELECTRONICS 15

letters

TV TYPEWRITER NOTES AND COMMENTS

The overwhelming response by our readers to the article "Build A TV Typewriter" by Don Lancaster in the September 1973 issue of **Radio-Electronics** has been staggering. We are just getting out from under the thousands of requests we have had for the TV Typewriter brochure and offer our apologies to those readers who have encountered delays in obtaining their copies of the brochure.

This same tremendous response has created shortages in the parts needed to build the TV Typewriter and, therefore, we are listing here several possible sources of parts.

Southwest Technical Products Corp., 219 West Rhapsody, San Antonio, Texas 78216, has the following parts for this project: etched and drilled fiber glass circuit boards for timing, memory and cursor at \$5.75 each; the main frame circuit board is \$9.75 each; set of MOS circuits consisting of the 2513,

2518 and six 2524's—price for a tested set of these eight IC's is \$49.50. No other parts are available from Southwest. Keyboards are sold out.

Many of the 7400 series of IC's are available from regular advertisers in **Radio-Electronics**. Check the ads in the back of the book. The 74177 which is directly interchangeable with the 74197 is harder to get. Poly Paks, P.O. Box 942R, Lynnfield, Mass. 01940, offered this IC for \$2.10 in their ad in the October issue.

Potential sources for keyboards that appear to be suitable follow. Keyboards are available in a limited quantity on a first-come first-served basis only.

B&F Enterprises, 119 Foster Street, Peabody, Mass. 01960, model KB-3; (surplus) non-decoded alphanumeric keyboard is \$24.50 plus postage; KB-01 (surplus) teletype format ASCII encoded keyboard is \$44.50.

Hansen Associates, P.O. Box 806, Ridgewood, N.J. 07451, has a supply of

new keyboards available, \$98.00 each plus postage.

Solid State Sales, P.O. Box 74D, Somerville, Mass. 02143. New Raytheon ASCII encoded units are \$60.00 each plus postage.

KA Electronic Sales, 1312 Slocum Street, Dallas, Texas, microswitch keyboards (surplus) are \$50.00 each plus postage.

The power transformer is available from Signal Transformer Company, One Junius Street, Brooklyn, N.Y. 11212 at \$6.00 plus postage.

Molex sockets are available from Force Electronics, 343 South Hindry Avenue, Inglewood, Calif. 90301. The sockets (09-52-3103) are 34¢ each. The matching pins (09-64-1101) are 39¢ per 10-pin assembly. Minimum order \$10.00 plus 50¢ postage.—*Editor*

DON LANCASTER COMMENTS

Here are some additional comments
(continued on page 22)

INTERNATIONAL Frequency meter FM-2400CH

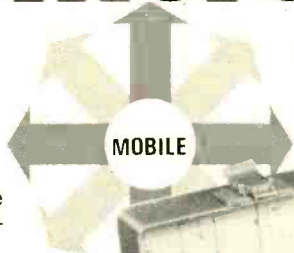

The FM-2400CH provides an accurate frequency standard for testing and adjustment of mobile transmitters and receivers at predetermined frequencies.

The FM-2400CH with its extended range covers 25 to 1000 MHz. The frequencies can be those of the radio frequency channels of operation and/or the intermediate frequencies of the receiver between 5 MHz and 40 MHz.

Frequency Stability: $\pm .0005\%$ from $+50^\circ$ to $+104^\circ\text{F}$.

Frequency stability with built-in thermometer and temperature corrected charts: $\pm .00025\%$ from $+25^\circ$ to $+125^\circ$ (.000125% special 450 MHz crystals available).

Self-contained in small portable case. Complete solid state circuitry. Rechargeable batteries.

WRITE FOR CATALOG!

- Tests Predetermined Frequencies 25 to 1000 MHz
- Extended Range Covers 950 MHz Band
- Pin Diode Attenuator for Full Range Coverage as Signal Generator
- Measures FM Deviation



FM-2400CH (meter only)	\$595.00
RF crystals (with temperature correction)	24.00 ea.
RF crystals (less temperature correction)	18.00 ea.
IF crystals	catalog price

INTERNATIONAL
CRYSTAL MFG. CO., INC.
10 NO. LEE • OKLA. CITY, OKLA. 73102

After so many high-fidelity and consumer publications rated our HD 414 "open-aire" headphones tops in sound, comfort and value, why would Sennheiser introduce another model?

The reason is perfection.

Not that our new HD 424 is perfect. But our engineers—the same engineers who developed our dynamic and condenser microphones for the recording industry—have made some significant advances. Enough, we feel, to warrant a new model. Enough, that a certain kind of music lover will appreciate the added fidelity, despite the added cost.

The primary difference is response. As linear as our HD 414 is, the HD 424 boasts even greater accuracy—particularly at low bass and high treble frequencies. Due to an improved transducer assembly and redesigned earpiece geometry. Heard on the HD 424, low organ notes assume an additional, fundamental richness without sacrificing the "tightness" of good transient response. While violins and other high-overtone



instruments retain the additional "transparency" their overtones produce.

No less important, especially for long listening sessions, is comfort. Retaining the "unsealed" free-air feeling so many praised in the HD 414, the new HD 424 provides even less (!) pressure on the ear, distributing it over wider, thinner acoustically transparent cushions. For this reason—and an improved, cushioned headband—the HD 424 actually seems lighter than the 5 oz. HD 414, even though it is slightly heavier.

Now, there are two Sennheiser "open-aire" headphones for you to choose from. The HD 414, rated best for sound and comfort. And a new model offering something more. That's why.

Hear them both at your Sennheiser dealer, or write us for more information. Sennheiser Electronic Corporation, 10 West 37th Street, New York 10018.

Manufacturing Plant: Bissendorf, Hannover, West Germany



Circle 6 on reader service card



NTS Home-Training in Electronics was the start of something big for James Gupton

An NTS Graduate

James A. Gupton Jr. graduated from National Technical Schools with a diploma in TV & Radio Servicing. Today, he's a mighty important man in the world of Electronics!

Research associate with a major electronics corporation; author of numerous articles in electronics magazines; an inventor with five patent applications to his credit. In the field of electro-optics, he has perfected a revolutionary phosphor deposition technique for cathode ray tubes.

Quite a list of accomplish-

ments for a man who began his career with an NTS diploma and a job in TV & Radio servicing.

Any student can succeed

James Gupton is certainly an exceptional NTS graduate. He proves there's nothing to keep a determined man from becoming a success in Electronics. As he himself says, "Any student, properly motivated, can succeed in Electronics through home-training."

Every NTS Electronics Course is specially designed to keep you motivated from the time you

start building your first test instrument until you're ready to plug-in your solid-state Color TV or other advanced electronics equipment.

Exciting "Project Method" Training

NTS Project Method Training is the best way to learn electronics.

You build advanced equipment while you learn Electronics principles and applications.

Each week brings new excitement when you actually see the progress you've made.

NTS builds self-confidence.

For a man to become successful, like James Gupton, he must have confidence in himself.

As an NTS graduate you have this confidence. Your training is practical and thorough. You know Electronics from the bottom up. You enter a world of Electronics you're familiar with.

And if you have the drive and determination of a man like James Gupton, there are no limits on your success!

(James Gupton's address available upon request).

NTS COLOR TV SERVICING



Solid-state
315 sq. in.
Heath Color TV

Build and keep the largest, most advanced color TV made! Over-all solid-state design, ultra-rectangular screen, matrix picture tube, built-in self-servicing features, "Instant On," A.F.T., solid-state, 24-channel detent UHF/VHF power tuning, and much more! Also build and keep AM-SW Radio, solid-state Radio, FET Volt-Ohmmeter, and Electronic Tube Tester. Learn trouble-shooting, hi-fi, stereo, multiplex systems, radio, color and B&W TV servicing.

NTS B&W TV SERVICING

Learn sophisticated solid-state circuitry as you build this B&W TV Receiver, Lo-Silho "Superhet" Radio, FET Volt-Ohmmeter, solid-state Radio, Electronic Tube

Solid-state
B&W TV,
74 sq. in.
picture
(cabinet
included)



Big, Colorful NTS Guide to new opportunities in Electronics. Yours FREE!

NATIONAL TECHNICAL SCHOOLS
4000 S. Figueroa Street
Los Angeles, California 90037

Please rush me FREE Color NTS Electronics Guide & FREE lesson, plus information on course checked at right. No obligation. No salesman will call.

Checker, and Signal Generator. TV and all other equipment are yours to keep.

NTS ELECTRONIC & COMPUTER TECHNOLOGY

Solid-state Compu-Trainer 14 integrated circuits replace 198 Transistors!

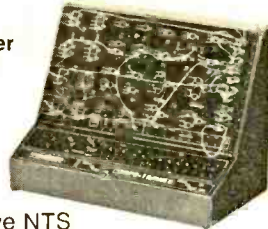

Build and keep this exclusive NTS Compu-Trainer. It teaches you the same principles used in million-dollar systems. Contains 14 integrated circuits! All solid-state! You perform all wiring and patchcording. No shortcuts. No pre-wired circuit boards. Your training is complete! Also receive a FET Volt-Ohmmeter and a 5" wide-band solid-state Oscilloscope.

NTS ELECTRONIC COMMUNICATIONS

Gain the prestige and earning power of owning and F.C.C. First Class Radio-Telephone license. Two comprehensive NTS Courses cover the big opportunity field of transmitting and receiving.



5-watt AM
Transmitter/
Receiver

You build and keep 14 kits, including this amateur phone 6-meter VHF Transceiver, NTS's exclusive 6-transistor solid-state Radio, and a fully transistorized Volt-Ohmmeter. Also, learn 2-way radio, Citizens Band Microwaves, and radar.

NTS INDUSTRIAL & AUTOMATION ELECTRONICS

Automation is the future of industry, and you can play an important part! Learn industrial controls by training on the NTS Electro-Lab (a complete workshop). You also build and operate this 5" solid-state

oscilloscope. And you perform experiments that involve regulating motor speeds, temperature, pressure, liquid level, and much more. All equipment is yours to keep.



All solid-state!

NTS AUDIO ELECTRONICS SERVICING

Learn sound theory — how it works in home radio, car tape decks, stereo multiplex component systems, and more! Set up a spectacular music system. Learn about sound distortion, amplification and control, loud-speaker baffles, problems of system installation, etc.

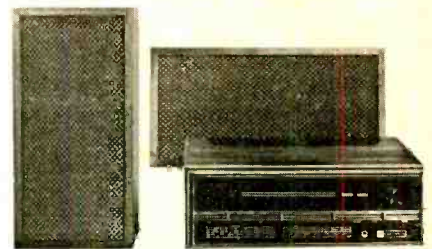

Build and keep this famous Heath Stereo Receiver and Speakers

Included is Volt-Ohmmeter, In-Circuit Transistor Tester and solid-state Radio. Prepare yourself for great opportunities in the Home Entertainment Industry!

CLASSROOM TRAINING AT LOS ANGELES

You can take classroom training at Los Angeles in sunny Southern California. NTS occupies a city block with over a million dollars in technical facilities. Check box in coupon below.

APPROVED FOR VETERAN TRAINING

Accredited Member: National Association of Trade and Technical Schools; National Home Study Council.

NATIONAL TECHNICAL SCHOOLS

World-Wide Training Since 1905
Resident & Home Study Schools
4000 S. Figueroa St., Los Angeles, Ca. 90037

Dept. 206-113

NAME _____ AGE _____

ADDRESS _____

CITY _____

STATE _____ ZIP _____

- Check if interested in Veterans Training under new G.I. Bill.
 Check if interested ONLY in Classroom Training at Los Angeles

- MASTER COURSE IN COLOR TV SERVICING
 COLOR TV SERVICING (FOR ADVANCED TECHNICIANS)
 MASTER COURSE IN B&W TV & RADIO SERVICING
 MASTER COURSE IN ELECTRONIC COMMUNICATIONS
 PRACTICAL RADIO SERVICING
 FCC LICENSE COURSE
 MASTER COURSE IN ELECTRONICS TECHNOLOGY
 AUTOMATION & INDUSTRIAL ELECTRONICS
 COMPUTER ELECTRONICS
 BASIC ELECTRONICS
 AUDIO ELECTRONICS SERVICING

LETTERS

(continued from page 16)

from Don Lancaster which may help answer other reader questions:

A color TV set has a video bandwidth of only 2.5 MHz; a black and white set has slightly more. This limits the number of characters per line to 32 or possibly 40, if an unmodified stock TV is to be used, particularly an economy one. Commercial terminal systems of 72 or 80 characters per line use special video systems with bandwidths of almost 10 MHz.

More memory can be added, but

since the memory is the most expensive part, it very much ups the cost. Considering the limitations on video bandwidth and overscan on an unmodified TV, it would be difficult to do more than 512 characters per page. Of course, if you want to modify the TV, you can get denser displays.

If you want an all-the-time fixed memory, use a read-only-memory or data selector instead of the shift registers used. There is no memory device I know of that is cheap enough to use with the TV typewriter, can be written into very rapidly and simply, and still keeps its information when power is disconnected. Mag core comes close, but is complex

and hard to use on a small system. So do erasable ROM's, but it takes a while to program them. Next year, we'll probably see better devices; right now, I don't know of any. Most terminal applications don't need memory through power-down times anyway, and those that do can run on stand-by power.

At least $\frac{1}{3}$ and preferably $\frac{1}{2}$ the scan in each direction must be saved for retrace and blanking, particularly on economy TV's.

To obtain full interlace (The only time you either need or want full interlace is when you must superimpose your message on top of an existing, uncontrollable program source.) you get horizontal and vertical signals from the system you are going to superimpose the characters on. These must be separate and not combined as EIA sync. They also must be TTL compatible. You compare the two horizontal outputs with a phase detector such as the Motorola MC4044 and derive an error signal to correct the 4.56 MHz oscillator phase lock loop style. The crystal is removed and replaced with a capacitor and the voltage control input is driven by the error output of the phase detector. Cost of this modification is under \$10, but custom engineering is involved for each application.

Baudot and EBDIC and SELECTRIC codes are generated on the keyboard simply by redefining the key matrix, and possibly adding a flip flop or two. At the TV TYPEWRITER end, you have to add a read-only-memory such as the Harris PROM 0512 and another flip flop to convert to ASCII, or you can sometimes use commercial code converters.

We are trying to work up add-on's, but I am swamped with work right now, and they won't be immediately available. Custom engineering at this time, even at our incredibly exorbitant rates, simply isn't available. My thanks to the incredible number of readers responding to this project.—Don Lancaster R-E

CHANNELLOCK

Gives You More In Hand Tools Including

SNIPS THAT CUT
EVERYTHING,
EASIER AS BUTTER
ON THE
FOURTH OF JULY

You don't need the grip of a gorilla to cut "tough stuff" such as sheet metal, leather, gaskets, plastics, screening, rubber, roofing materials . . . not with a CHANNELLOCK snip in your hand. With little more effort than you'd use on paper shears, you'll ease these perfectly mated, precision ground cutting edges through the "tough stuff" . . . smoothly, accurately, positively. And happy day! No more blisters . . . the grips are cushion coated with durable dipped plastic. Like all our hand tools, CHANNELLOCK snips are drop forged of highest grade tool steel, scientifically heat treated . . . your assurance that they'll be tough, dependable helpers for years to come.

COMPLETE CATALOG INFORMATION is yours for the asking.

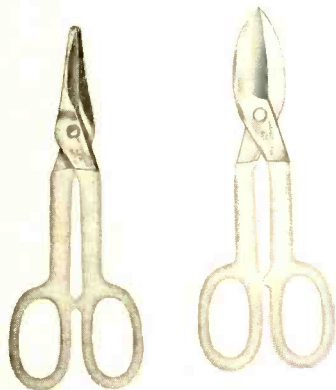
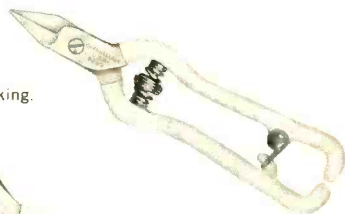

TOOLS BY
CHAN-NE-L-LOCK

MEADVILLE, PA. 16335



My kid made it. Found a picture in a book.



Our town



The sun never sets in our town, nor do our microphones and sound systems get any rest. "Our town" is the mecca for sound specialists, and here, Shure Microphones and Vocal Master Sound Systems handle it all: you'll hear them in hotel show rooms and lounges used by famous professional entertainers whose livelihoods depend on sound excellence; you'll hear them in hotel convention halls, in club after club, in casino after casino; and you'll hear them 'round-the-clock as keno scores are announced. Why? Because the predictability and reliability of Shure microphones and sound systems simply make everyone's job a lot easier. The Shure sound is the Las Vegas sound — and we're proud of it.

Shure Brothers Inc.,
222 Hartrey Ave., Evanston, Ill. 60204.



Circle 8 on reader service card

NOVEMBER 1973 • RADIO-ELECTRONICS 23

Kit...or

Heath test equipment is your best buy

Now you can buy Heath test equipment in easy-to-assemble kit form...or factory-assembled and calibrated. Either way you get service equipment with all the things Heath has become famous for: high quality...low direct-to-you prices...trustworthy specifications...long-term reliability...simple, rugged design...necessary features and functions built-in, not optional...manuals with complete schematics, circuit descriptions, parts lists and operating instructions...handsome brown & beige styling for our kits, striking black and white for the assembled versions...and local sales and service at Heathkit Electronic Centers in major metropolitan areas.

And you get something else that's really more important than excellent engineering or realistic prices: the total support and attention of everyone at Heath...honest, friendly, capable people sincerely interested in solving your problems and answering your questions. At Heath, "the customer is always right" is not a slogan...it's a way of life.



Kit and assembled instruments
available across the country
at Heathkit Electronic Centers:

ARIZ.: Phoenix; CALIF.: Anaheim, El Cerrito, Los Angeles, Pomona, Redwood City, San Diego (La Mesa), Woodland Hills; COLO.: Denver; CONN.: Hartford (Avon); FLA.: Miami (Hialeah), Tampa; GA.: Atlanta; ILL.: Chicago, Downers Grove; IND.: Indianapolis; KANSAS: Kansas City (Mission); KY.: Louisville; LA.: New Orleans; MD.: Baltimore, Rockville; MASS.: Boston (Wellesley); MICH.: Detroit; MINN.: Minneapolis (Hopkins); MO.: St. Louis; N.J.: Fair Lawn; N.Y.: Buffalo (Amherst), New York City, Jericho; L.I.: Rochester, White Plains; OHIO: Cincinnati (Woodlawn), Cleveland, Columbus; PA.: Philadelphia, Pittsburgh; R.I.: Providence (Warwick); TEXAS: Dallas, Houston; WASH.: Seattle; WIS.: Milwaukee.

Assembled

Everything you need in service equipment... at the price you want to pay. Our 2½-digit DMM (A), for instance, is just \$79.95* as a kit, \$120* factory-assembled. Prefer a VTVM? The famous IM-18 kit (B) is just \$29.95*... only \$55.95* for its wired counterpart. Our bench VTVM (C) is only \$39.95* in kit form, \$59.95* assembled. And our AC VTVM (D) is \$41.95* as a kit, just \$59.95* wired. Need a good scope? We have two... both loaded with features and priced right. The DC-15 MHz model (E) is only \$329.95* in kit form, \$475* wired. For \$119.95* you can assemble our DC-5 MHz model (F)... for \$179.95* we'll do it for you.

If you do TV alignment, take a good look at our post marker/sweep generator (G). Probably the most versatile instrument available for the price, it's only \$139.95* as a kit, just \$199* wired. Check out our color bar/pattern generator too (H). The kit is just \$79.95*; factory wired only \$114.95*. We have other generators too: our sine-square wave version is only \$69.95* kit, \$99.50 wired (I). And our audio generator (J) is equally low in price... \$49.95* kit, \$74.95* wired. Power supplies? Our low voltage model (K) is just \$79.95* as a kit, \$125* wired. The high voltage model (L) is just \$69.95* in kit form, \$110* wired.

Buy your equipment in kit form and enjoy maximum savings. Or order it factory-assembled & calibrated, ready to go to work for you right out of the box. Either way, you get versatile, quality equipment at a reasonable price. Order the instrument of your choice now... or use the coupon to send for your FREE new Heath catalog.

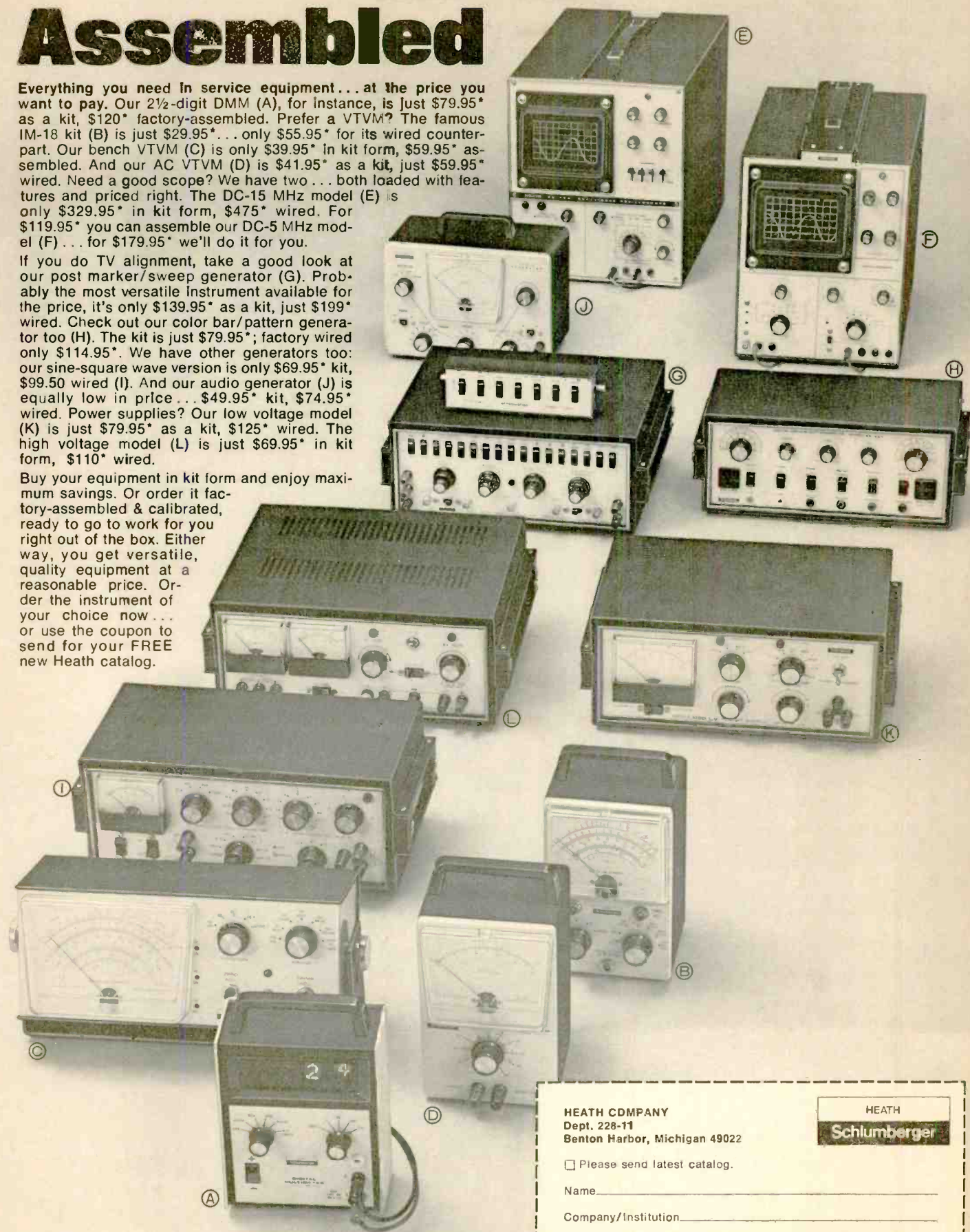

HEATH COMPANY Dept. 228-11 Benton Harbor, Michigan 49022		HEATH Schlumberger
<input type="checkbox"/> Please send latest catalog.		
Name _____		
Company/Institution _____		
Address _____		
City _____ State _____ Zip _____		
* Mail order prices; FOB factory TE-295RR		

Circle 100 on reader service card

The first NEW amplifier design since



the ORIGINAL Super Amp

You remember the first super power amplifier - the Crown DC300. Well, most of its competitors are still using those six year old circuit designs pioneered by Crown. Most every amp but Crown's new **DC300A** - a totally redesigned amplifier inside and out. Frankly, the DC300A is not created for the hi fi mass market, but for demanding commercial and professional applications. However, we know there are discerning audiophiles, perhaps like yourself, who can appreciate the difference.

The new DC300A has double the number of output transistors, effectively twice the muscle of the old DC300 for driving multi-speaker systems. Each channel has eight 150-watt devices for 1200 watts of transistor dissipation per channel. Advanced electronic output protection permits the DC300A to drive the toughest speaker loads at higher outputs before going into protection, and even then there are no annoying flyback pulse noises or DC fuses to blow.

The new DC300A has unprecedented signal purity. IM and harmonic distortion ratings are .05%, although typically below .025%. Hum and noise rating is 110dB below 150 watts, while typically -122dB. The difference in increased listening comfort is impressive.

Although totally new, the DC300A has inherited some important traits from its predecessor:

PRICE - still under \$700

WARRANTY - three years on all parts, labor and round-trip shipping

POWER RATING - 150 w/ch continuous at 8 ohms; power at clip-point typically 190 w/ch at 8 ohms, 340 w/ch at 4 ohms, 500 w/ch at 2.5 ohms, or plug in two parts for 600 watts continuous mono power at 8 ohms.

There are many new super-power amplifiers. But when you buy a Crown DC300A, you're buying more than just an amp. You're buying the Crown company - a professional audio equipment manufacturer with a 26-year reputation for solid quality and lasting value. There are thousands of Crown amps in the field still working to their original specifications, and still outperforming most new amps. Visit your Crown dealer to hear the difference. For detailed product data, write Crown International, Box 1000, Elkhart, Indiana, 46514.



crown

Circle 9 on reader service card

appliance clinic

ELECTRONIC MATCHES

by JACK DARR
SERVICE EDITOR

ELECTRONIC PRINCIPLES ARE POPPING up all over these days. Now, they're in your pocket and everywhere else. Here are two applications.

The first is a fully electronic lighter. It's fueled by butane, which isn't new. But in place of the old "Thumb-Buster" spark wheel this one, made by the well-known Ronson Co., has a fully electronic ignition system!

This is actually a "super-miniaturized" version of the capacitor-discharge ignition system used on racing cars! Fig. 1 shows an exploded view. One battery, one capacitor, a diode and a step-up transformer, with spark electrodes to do the actual igniting.

All this is operated by the switch button, which opens the butane burner valve at the same time that it fires the spark. The whole thing is compact, no larger than other lighters.

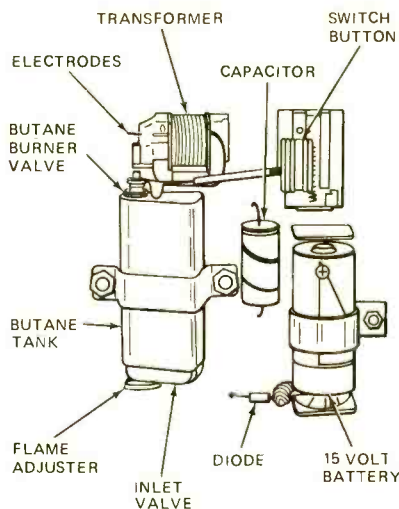

FIG. 1

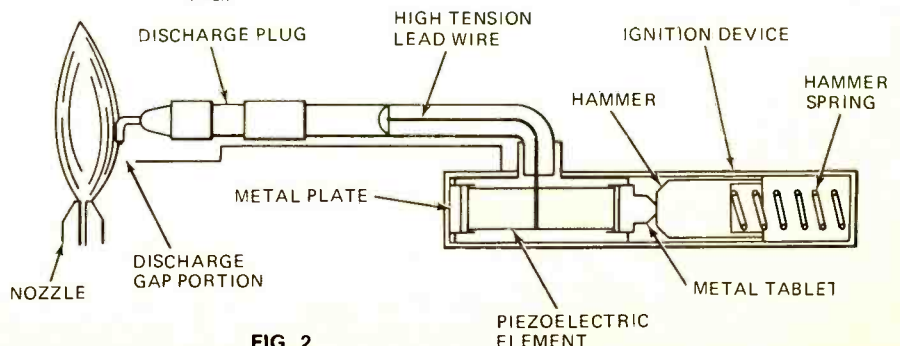

FIG. 2

The second device is another "lighter." This one has even fewer parts, and is used to ignite gas flames for welding torches, stoves, or any kind of gas-burning device. It works on another well-known principle of electronics; this time the heart of the device is a special piezoelectric element. When a piezoelectric crystal is compressed, or struck, it generates a pulse of voltage. In the application we're most familiar with, this reaction makes music in a phono cartridge.

Fig. 2 is a cross-section of the heart of one of these units. This is a handheld type, for any application requiring portability. A specially designed piezoelectric element, in the form of a rod, is mounted so that two crystals have their positive ends connected together. This places two elements effectively in parallel, to increase the current flow.

A hammer is mounted, with a spring, so that it can be cocked and then tripped to strike the end of the piezoelectric unit. When it does, a high voltage is generated. This is fed through a series resistor to the arc electrodes at the tip, the "discharge plug". The resistor is included to make the arc more efficient in igniting a gas-air mixture. It prolongs the arc discharge.

There's not much of anything to "service" on these! About the only thing that can make trouble is an accumulation of dirt or grease between the arc electrodes. These can be cleaned by carefully poking a toothpick between them. This unit actually develops up to 14 kilovolts.

The unit shown here is a home device, intended for lighting gas stoves. Industrial types are also made, for furnaces, heaters, etc. These come from Panasonic. **R-E**

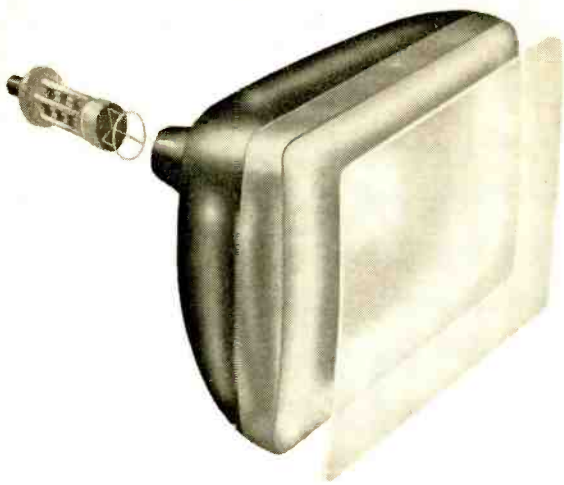

How some tubes are rebuilt.

1. Inspect screen and replace electron gun.
2. Reinstall safety glass.
3. Test tube.

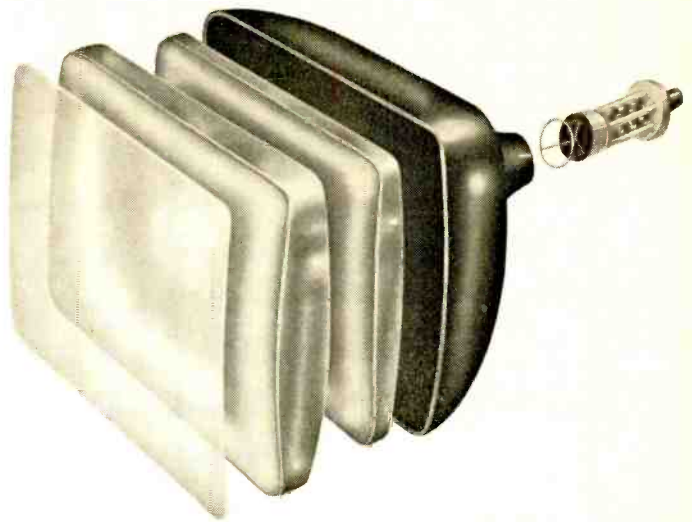

How our color bright 85^{RE} is rebuilt.

1. Completely clean old glass so it gleams like new.
2. Apply new internal and external coating to the bulb.
3. Replace phosphors with Sylvania high-brightness types.
4. As required, install new aperture mask with Sylvania thermal compensation system.
5. Replace electron gun with Sylvania electron gun assembly.
6. Install new implosion protection system.
7. Final test.

Every tube is remanufactured and tested on the same assembly line used for our new color tubes. And that line includes the latest computer-designed improvements in screen exposure optics. In short, when you install a Sylvania *color bright 85RE* picture tube, you are installing a tube that is practically brand new except for the glass. In fact, if we rebuilt it any further, it would be a new tube.

Available at your local Sylvania distributor.
Sylvania Electronic Components,
100 First Avenue, Waltham, Mass. 02154

GTE SYLVANIA

free

1974

Olson CATALOG



**SAVE on the NEWEST
and BEST in famous-
name product lines . .**

**A superstore of electronics
at your fingertips**

- Stereo / 4-Channel Sound Systems
- Tape Recorders and Accessories
- Radios • Phonos • Kits • Amateur and Shortwave Gear • Citizens Band
- Antennas • Police/Fire VHF-UHF Radios • Electronic Calculators and Timepieces • Security • Test Equipment • 1000's of Parts, Tubes, Batteries, Wire, Hardware

**Exclusive TELEDYNE and OLSON
Audio Products**

Olson
for the electronics in your life
the VALUE leader since 1931

**FREE
1974 Catalog
Send coupon
today**

Olson electronics Dept LN
260 S. Forge St., Akron, Ohio 44327

Send me my FREE 1974 Olson
Catalog (Please Print)

Name _____ Apt. _____

Street _____

City _____ State _____ Zip _____

Send an Olson Catalog to my friend.

Name _____ Apt. _____

Street _____

City _____ State _____ Zip _____

Circle 10 on reader service card

equipment report

Data Precision 245 Digital Multimeter



Circle 95 on reader service card

GOOD THINGS COME IN SMALLER AND smaller packages these days. A perfect example of this is the Data Precision Corp. model 245 DMM (Digital Multimeter). This 4½ digit multimeter will sit in the palm of your hand. It's 5½" wide, 3½" deep and 1¾" high. It will read ac and dc voltages, ac or dc current, and resistance on a total of 21 ranges. All of these, except the two high-voltage ranges on ac and dc, have the handy 100% overrange feature. In other words, on the 0 to 1-volt range, you can read up to 1.9999 V. (The last digit indicates hundreds of microvolts.)

If you go over the maximum on any range, the digits go out, leaving the decimal point and polarity indicator lit. Four ranges are used for all measurements; 1.0, 10, 100 and 1000. The decimal point shifts automatically when the range switch is moved. The only thing that could be confusing here is the resistance range. This plainly states that it is "k-ohms". So, the 0 to 1 scale here means 1000 ohms full scale, which will overrange up to 1.9999. A reading of 1.5000 means "1.5 thousands" or 1500 ohms.

The model 245 DMM is powered by a rechargeable internal battery pack. The charger comes with it. The display uses 7-segment characters. These are bright enough to be read in sunlight.

This is a highly accurate little jewel. All measurements can be read to within 0.005%, and the various scales are accurate to within 0.03% of reading ±1 LSD (Least Significant Digit or the last one on the right).

With this degree of accuracy, this meter could be classed as a lab-type instrument. However, it is certainly

handy around the shop, when you need precision readings. For example, I wanted to make a frequency-run on a large guitar amplifier. I cobbled up a voltage divider, hooked it across the output of my audio generator, then connected the model 245 across the little one, set on the 0 to 1 vac range. I wanted a 50-mV standard input signal at each frequency. No problem. Just twiddle the attenuator until the display reads .0500 and there you are. The ac voltage ranges of the 245 have a very good high-frequency response.

Sidelight: one of the "old grouch" objections to digital displays is the odd readings on ohms ranges. Some digital meters will rock or hunt with the prods open, which is disconcerting. Here is a solution; the 245, with prods open, has the equivalent of an over-range reading, so the display simply goes out. Incidentally, the resistance scales have an accuracy of 0.07% to 0.25% over the whole range.

A very complete instruction book comes with each unit. This includes not only operating data, but recalibration instructions.

The model 245 uses a unique patented circuit. They call it a "Tri-Phasic Analog-to-Digital Converter". The basic circuit is similar to the dual ramp A/D converter. However, this is divided into three phases. During Phase I, the 245 automatically servos each circuit, to determine the accumulated zero-offsets in the analog integrator loop. This automatically "sets everything to zero". In Phase II, the signal to be measured is fed, after conditioning, to the converter integrator. At the end of Phase II, Phase III starts; the input is disconnected from the A/D converter, and the reference signal, of opposite polarity, connected. This senses the zero-level on the integrating capacitor, and the end of conversion. If this is within normal range, it is read out. If it is overrange, the overload circuits are activated, and this condition is read out. The whole process takes only 400 ms.

A fascinating little instrument, and a very useful one. It should find a place in every electronics shop, no matter what field you're in. **R-E**

From Mits: New digital test equipment professional lab quality at shop cost.

Model 1700* Waveform Generator/Frequency Counter



Kit \$139.95 Assembled \$199.95

WAVEFORM GENERATOR: • 6 carrier waveforms including sine, triangle, square, ramp, saw tooth and pulse. Frequency range — from 1Hz to 1.5MHz in 12 overlapping ranges. • 3 internal AM or FM modulator waveforms including sine, triangle, and square. Frequency range — 100Hz to 150KHz in 6 overlapping ranges. Has ability to accept external AM or FM modulator signals. • 3 amplitude controls carrier only, modulator only or modulated carrier.

FREQUENCY COUNTER: • Measures frequency of the WFG output or frequency of external signals from 1Hz to over 10MHz. • 4 digit display of .55 inch Sperry gas discharge type. (same as DVM) • Adjustable sensitivity. • Has flashing overrange indication. • Features an event counter which can be used for external signals. • Input impedance — greater than 100K ohms. • External input clamped at ± 10 volts. • Sampling period — 1

second for Hz ranges, .1 second for Kiloherzt and Megahertz ranges. • Integrated circuit electronics construction.

POWER REQUIREMENTS: SPECIFY 115 OR 230 VAC, 60 Hz, 25 WATTS.

*FEATURED IN JULY 1973 RADIO ELECTRONICS COVER STORY

Model 1600 Digital Voltmeter

Kit \$89.95 Assembled \$129.95



- FUNCTIONS:**
1. AC Volts 4 Ranges from 1 volt to 1000 volts
 2. DC Volts
 3. AC Current
 4. DC Current
 5. Ohms-6 Ranges from 100 ohms to 10 megohms

RESOLUTION: (low ranges) Voltage-10mv • Current-10ma • Resistance-1 ohm

ACCURACY: DC Volts — $\pm .5$ • All others — $\pm 1\%$

INPUT IMPEDANCE: DC Volts — 10 megohms • AC Volts — 1 megohm

SAMPLE RATE: 5 per second **POWER REQUIREMENTS:** Specify 115 or 230 VAC, 50/60 Hertz, 20 Watts.

- 2-1/2 digits of large .55" Sperry gas discharge display • Can be read from up to 40 feet away in direct sunlight • Integrated circuit technology throughout
- Auto polarity feature automatically displays polarity and magnitude w/o probe reversal • Regulated power supply • 100% overrange capability on all ranges

ITC-1800 Integrated Circuit Tester

Kit \$119.95 Assembled \$169.95

SPECIFICATIONS: • 18 LED indicators show status of IC under test • Internal 5 volt 1 amp power supply. Internal 2 speed clock • Single step capability • Cross bar switch allows complete programming of IC under test • 4 remote outputs • 4 remote inputs

Detailed instruction manual (includes diagrams of all common digital IC's)

SIZE: 8" x 9" x 3-1/2" POWER: 50/60Hz 115 VAC 8 watts WEIGHT: 9 lbs.

The ICT-1800 is ideal for testing digital integrated circuits. It also may be used to breadboard ICs while developing circuits. The ICT-1800 is as indispensable for testing ICs as the vacuum tube tester was for testing vacuum tubes.

mits®

Micro Instrumentation & Telemetry Systems, Inc.

6328 Linn, N.E., Albuquerque, New Mexico 87108
505/265-7553 Telex Number 660401

Enclosed is a Check for \$ _____

or BankAmericard # _____

or Master Charge # _____

Credit Card Expiration Date _____

Include \$5.00 for Postage and Handling

Model # _____ Kit Assembled

Please Send Information on Entire MITS Line.

NAME _____

ADDRESS _____

CITY _____

STATE & ZIP _____

MITS/ 6328 Linn, N.E., Albuquerque, New Mexico 87108 505/265-7553 Telex # 660401

Circle 11 on reader service card

Here's everything you'd expect from a high-priced signal generator.

Except a high price.

The accuracy of your tests depends on your signal generator. But you needn't pay high prices for accuracy — B & K is proud to introduce our Model 2050 Solid-State RF Signal Generator, with features other companies charge more for. Just look at our specs: 100% Solid-State Silicon Circuitry featuring FET's in RF and audio

oscillator stages for greater stability and linearity. Six bands, with ranges from 100 kHz to 30 MHz with 1.5% accuracy. 3 outputs: RF, modulated RF (400 Hz) and externally modulated RF. A big multi-colored, 4½" vernier dial, with positive anti-backlash dial drive. Zener-regulated and internal fuse-protected power supply.

You needn't pay high prices for versatility, ruggedness and accuracy in a signal generator — now there's the Model 2050. It's just what you'd expect from B & K.

Contact your distributor for full information, or write Dynascan Corporation.

\$999⁹⁵



B&K Very good equipment at a very good price.

Product of Dynascan Corporation/1801 W. Belle Plaine Ave., Chicago, Ill. 60613



BUILD THIS Digital Stopwatch

Your choice of 3, 4, 5, or 6 digits. Tells time; times events; remote start and stop; IC and printed-circuit construction for a low-cost precision timer

by W. L. GREEN*

THROUGHOUT THE AGES, MAN HAS created myriad devices for the purpose of indicating and measuring time. They range from water clocks and sundials in ancient times, to mechanical escapement and tuning fork timepieces in more modern times. The National Bureau of Standards transmits time of day and precise frequency and time intervals via radio stations WWV, WWVB and WWVH.

The quartz-crystal oscillators these standards are derived from, are accurate and stable to 1 part in 10^{12} (0.0000314 second per year). A large number of high-cost instruments are available that can accurately display and/or measure time. And there are others that can control the start, stop and on time of another device. But few will do all these things.

The Universal Stopwatch/Timer is a pocket sized (5"x3"x1/4") battery operated digital stopwatch, clock and

control timer. It will do all of the above mentioned things at a reasonable price. (Under \$50 for the three-digit readout version, see parts list.)

Its large, bright 0.27" high LED display is readily visible in high ambient light areas, and, depending on the timebase and source of power used, its accuracy can be maintained between a few seconds per day, to a fraction of a second per year, calibrated to WWV.

Although the Stopwatch may be used as a very accurate 12 or 24-hour clock, its other uses are somewhat more outstanding. For aerial, boat or automobile rally navigation, it acts as an elapsed-time indicator. It will do the same job for automobile, animal and human racing. In addition, the Stopwatch has many uses in the dark-room, because of its internal coincidence detector, which may be set for start/stop delays of up to 24 hours.

Its use is simple, and once the operation is mastered, many other uses will be found, ranging from cooking an egg for precisely 3 minutes, to measuring the time it takes for a model rocket to reach its apogee after liftoff.

Technical description

The small size of the stopwatch results from the use of a single MOS/LSI integrated circuit. In this 24-pin ceramic package is the logic to provide the 1-Hz time-base signal from the external clock, the time and timer counters (six digits each), gating for the time and timer set switches, the coincidence detector for the timer, the multiplexer and decoder for the display. (See block diagram, Fig. 1).

The accuracy at low cost is made possible by the MC1455 timer IC. This 8-pin plastic package houses 2 comparators, a flip-flop and several

*President, Alpha Electronics

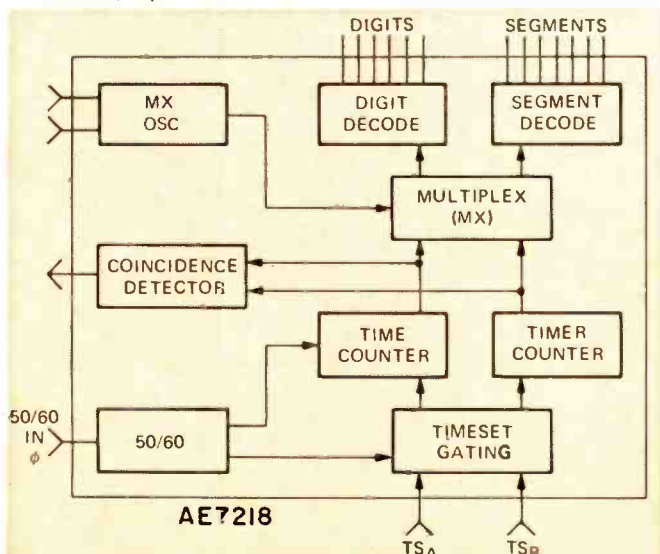

FIG. 1—PARTIAL BLOCK DIAGRAM shows contents of single MOS LSI IC that forms the heart of the timer.

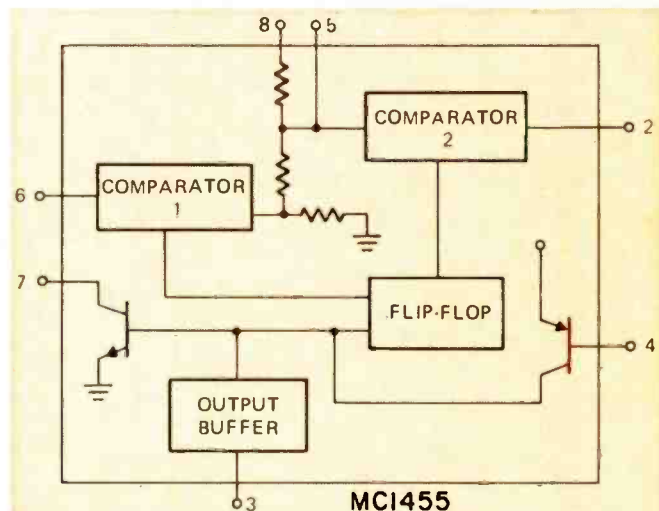

FIG. 2—THIS BLOCK DIAGRAM is the MC1455 IC timer that houses two comparators, a flip-flop, plus several transistors for reset, external timing capacitor discharge and output buffering. In this circuit it is used as an astable MVB.

transistors for reset, external timing capacitor discharge and output buffering. (See block diagram, Fig. 2.)

In this particular application, it is wired as an astable multivibrator with a nearly symmetrical output square wave, whose frequency is, within limits, independent of the supply voltage, and whose temperature stability is .005%°C. This output signal is fed to the θ input on the AE7218 MOS IC. Its frequency may be set to 50/60 and 500/600 Hz, depending on the application of the Stopwatch. The time-shared outputs from the segment and digit lines on the IC, are buffered by the 13 npn transistors.

These transistors supply voltage to the segments of the display in parallel, and return the cathodes of each individual digit to ground at the appropriate time—when the data at the segments is true for that digit. The associated resistors are for current limiting and logic return at the bases of the driver transistors. The resistors connected to the MC1455 set its duty cycle and frequency, in conjunction with capacitor C1. The adjustable resistor allows precise adjustment of the clock's frequency to 50/60 or 500/600 Hz.

The oscillator frequency is independent of supply voltage drift, because it is determined by the ratio of R1 and R2 + R3 and the value of timing capacitor C1. Capacitor C1 charges to $\frac{2}{3}$ of V+ thru R1, R2 and R3, and discharges to $\frac{1}{3}$ of V+ through R2 and R3. The device is free running because the voltage on the timing capacitor is fed back to the trigger input.

How to build one

Construction is not difficult or

lengthy, and anyone with some experience in electronic kit construction should have little difficulty building it. One word of caution, however, as with any MOS device, the AE7218 IC must be carefully handled to avoid damage to the inputs by static electricity. Do not use a soldering gun after this IC has been installed.

The PC layouts are shown in Figs. 3 and 4. The parts layout is in Figs. 5 and 6. A set of etched and drilled PC boards is available (see parts list) or you may make your own. Install and solder all the jumpers, resistors and capacitors on the main board first, (jumpers go on the foil side) then the diodes and transistors, being sure to observe polarity. (A "C" on the board indicates the diode cathode).

FIG. 3—FOIL PATTERN for the main circuit board. This board, full size, is 5 inches wide.

FIG. 4—(below) FOIL PATTERN for the display board. Actual size of the board is 5½ inches wide.

FIG. 5—(bottom below) DISPLAY board showing parts placement.

FIG. 6—(below right) MAIN board showing parts placement.

Now install IC1 and solder it. Then remove the conductive packing from the pins of IC2 and carefully install and solder it using fine solder and a small soldering iron. Be sure to align the identifying marks as shown. Insert and solder the jumpers on the display circuit board (on the foil side). Then install and solder the individual digits on the board noting that the identifying notches on one of the narrow edges of each digit goes toward the bottom of the board. These digits are installed up-side down so that the decimal points of the second and fourth digit separate the hours, minutes and seconds of the display.

Although the display board is laid out for six digits, less than that num-

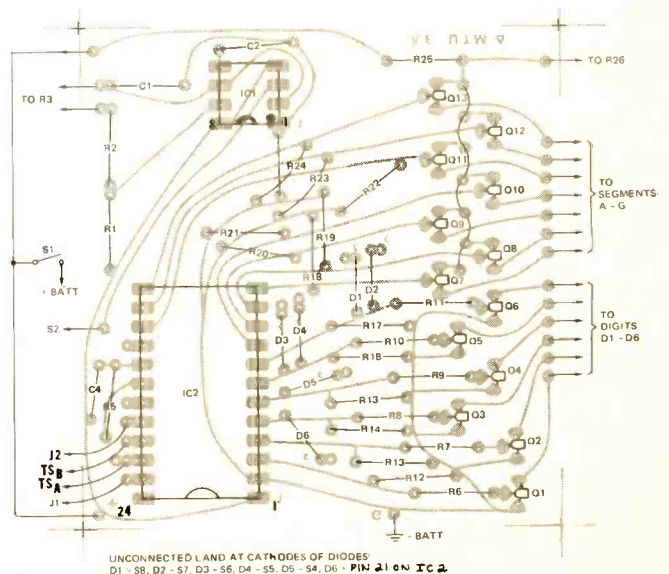
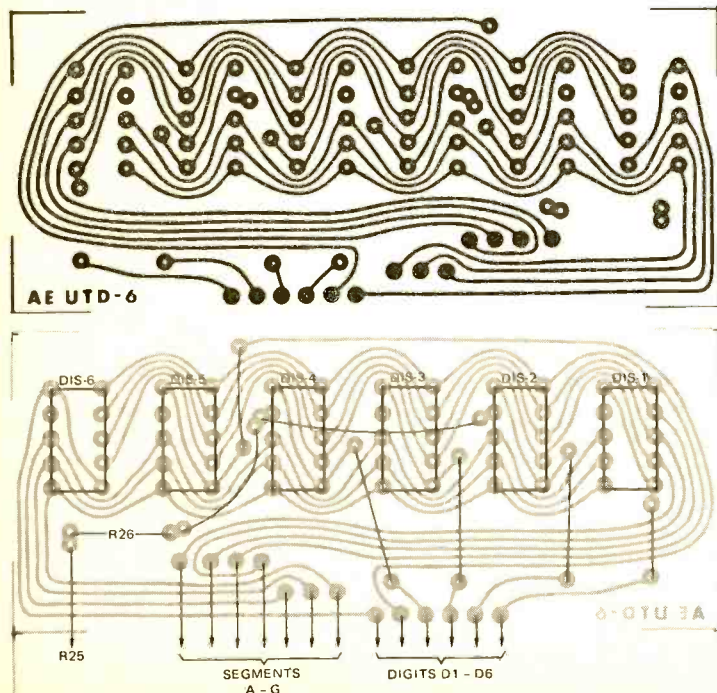
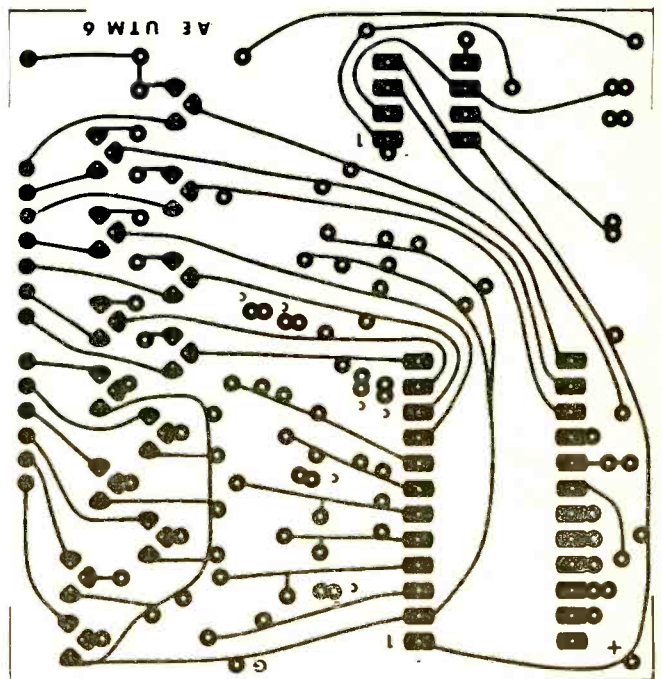

ber may be used, as dictated by the application. Install the display module in an appropriate case (a case like the one shown is available, see parts list) along with the time set switches and input and output jacks and wire them all to the main circuit board.

As mentioned before the Stopwatch can be powered by internal batteries, conventional or Ni-Cad, or by an external dc source. This can be an ac/dc power supply, or with an adapter, directly from the cigar lighter socket in an auto. The only requirements for this source of power, is that it be between 7.5 and 14 volts and capable of supplying 100 mA.

A display on/off switch is included to increase the useful battery life between charges when the unit is operated from its internal batteries. In addition to the options of the number of digits in the display and the type of power source used, the Stopwatch may be wired for 12 or 24 hour time display. Connect a jumper from D1's cathode to IC2 pin 22 for 24 hour operation, or leave as shown for 12 hour display.

The θ input of IC2 must be fed a 60 Hz or 600 Hz signal unless a diode is connected from IC2 pin 5 (anode) to pin 22 (cathode), in which case the θ input will function properly with an input signal of 50 Hz or 500 Hz. Either way, the 50 or 60-Hz signal will cause the seconds digits (first two from right) to read seconds and tens of seconds, or tenths of seconds and seconds if 500 or 600 Hz is supplied at this point.

As mentioned earlier R3 may be adjusted to provide these clock frequencies from the MC1455 timer IC. Two resistors and a switch in place of R3 allow selecting the time-base frequency. An external source of power, reasonably well regulated, will give accuracies of a second or two per day. If greater accuracy is required, two alternate methods of time base generation may be used.

The first is the simplest and uses the 60-Hz power line frequency (see Fig. 7). This method, of course, limits the portability of the Stopwatch. The other method is to use a crystal oscillator and divider to give accuracies

on the order of a fraction of a second per year. A schematic for this type oscillator is shown in Fig. 8. With this type of time base, the unit can be operated from a portable power source. An additional feature or function of the Stopwatch is that the timer output may be used with one external transistor, capacitor and transformer, to drive a small speaker used as an audible alarm (see Fig. 9).

The output from the speaker will be about 700 Hz pulsing at 1 Hz. Figure 10 shows the external power control device. The pulsing signal at the timer output jack is rectified by the diode and filtered by the capacitor and applied to the gate of the SCR. When the SCR fires it supplies current to the relay coil and energizes the relay. The relay will remain energized until the timer signal is removed and the reset switch in the SCR's anode circuit is depressed.

The normally open and normally closed positions of the 6V relay enable the power control to turn an external load on, or off, upon command from the timer output on the Stopwatch.

PARTS LIST—MAIN CIRCUIT BOARD

R1, R4—1000 ohms, $\frac{1}{4}$ W, 10%
 R2—470,000 ohms, $\frac{1}{4}$ W, 10%
 R3—pot, 1 megohm, multiturn
 R5—18,000 ohms, $\frac{1}{4}$ W, 10%
 R6 thru R11—4700 ohms, $\frac{1}{4}$ W, 10%
 R12 thru R24—27,000 ohms, $\frac{1}{4}$ W, 10%
 R25—100 ohms, $\frac{1}{4}$ W, 10%
 R26—220 ohms, $\frac{1}{4}$ W, 10%
 C1, C2—0.01 μ F, 15V
 C3—220 μ F, 15V, electrolytic
 C4—100 pF
 Q1 thru Q13—MPS5172

D1 thru D6—1N914 or 1N4148
 IC1—MC1455 or 555 timer IC
 IC2—AE7218, Mostek MK5007
 DIS1 thru DIS6—FND70244 LED, Fairchild
 S1, S2, S3—spst slide
 S5, S6, S7, S8—spst pushbutton, N.O.
 S4—spst, pushbutton, N.C.
 J1, J3—phone jack, closed circuit
 J2—phone jack, open circuit
 BATT—7.5 to 14V, Eveready E401 mercury;
 E-90 alkaline; OB70T Ni-Cad
 Case, PC boards, wire, tubing, hardware.

The following parts are available from Alpha Electronics, P.O. Box 1005, Merritt Island, Fla. 32952.

Set of two etched and drilled circuit boards. **UTX-6-SET—\$4.00** PPD US
 LED display digit, 0.27" high, Fairchild **FND70244—\$3.50** per digit PPD US
 IC1 & IC2 (MC1455 & AE7218) **UTIC-SET—\$28.50** for both PPD US
 Complete kit with case and all parts except display digits and batteries, **UKT—\$39.00** PPD US

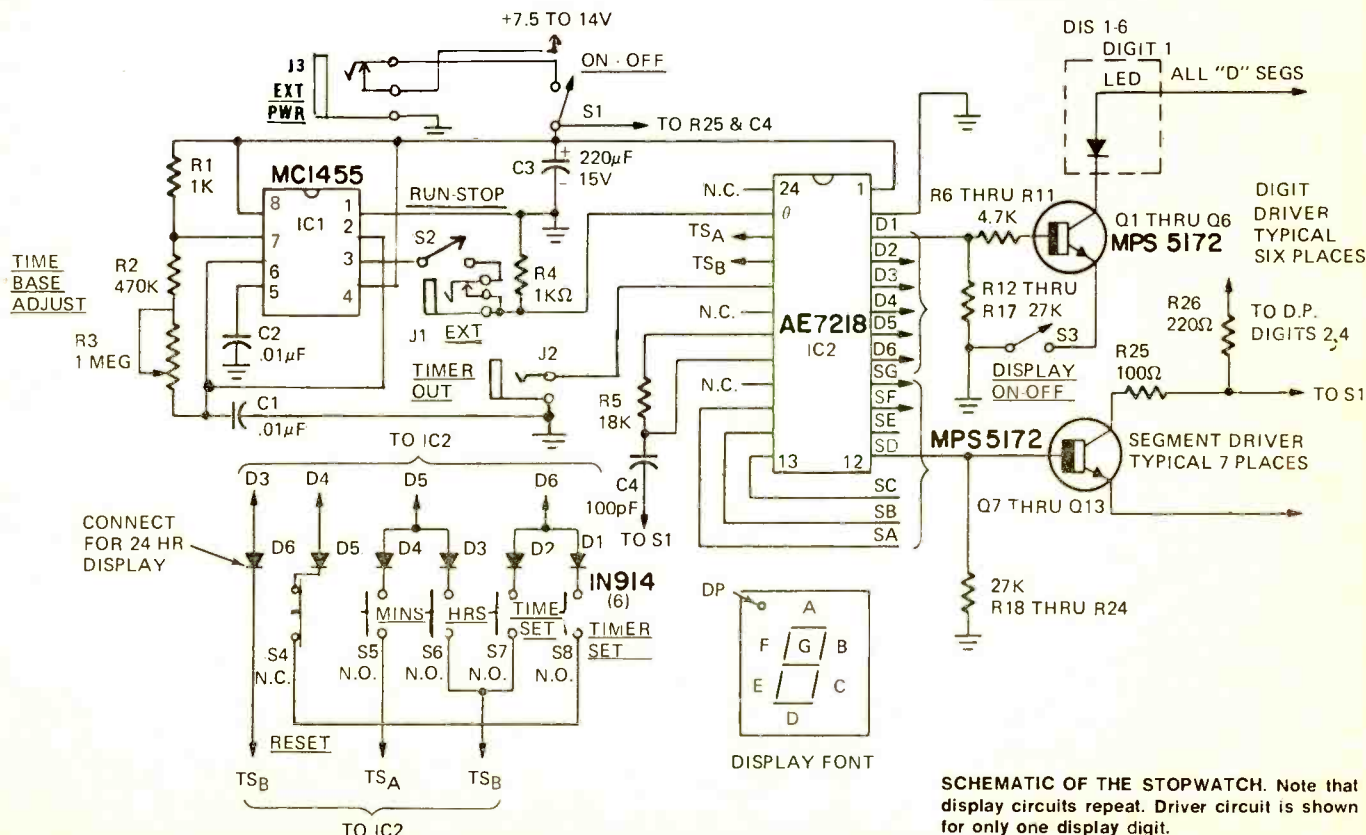

SCHEMATIC OF THE STOPWATCH. Note that display circuits repeat. Driver circuit is shown for only one display digit.

The power supply for the power control in the author's model is one of the battery eliminator types and supplies around 9 volts to the SCR and relay, but a conventional supply may be used.

Operation and use

When power is first applied, or when the power supply drops below 7.5V or is interrupted, the display will

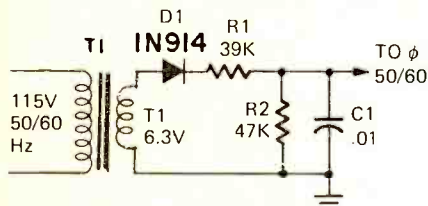

FIG. 7—SIMPLE AC SUPPLY can be used to power unit, but limits portability.

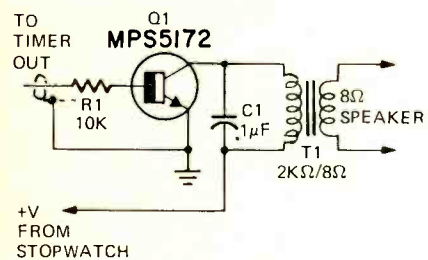
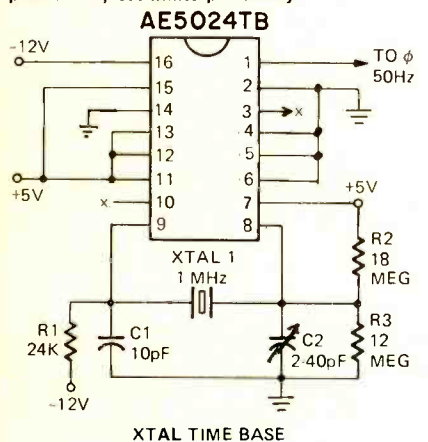

FIG. 8—(top) CRYSTAL OSCILLATOR and frequency divider provides portable accuracy. FIG. 9—(above) TONE AMPLIFIER drives speaker to act as audible alarm.

present all 8's. Depressing and releasing the TIME SET switch will clear the display and display 12'00'00 (6 digit displays only) or all zeros if the unit is wired for 24 hour operation. With the RUN/STOP switch in the RUN position, the far right seconds digit will step one count ahead per second.

If the TIME SET switch is depressed again, the first two digits will reset to zero and remain there until the switch is released. The RUN/STOP switch will stop the count, but will not reset the counter. Either of these switches may be used alone or together to control the counting of the Stopwatch.

If the HOURS switch is depressed, the hours digit steps at the rate of 2 Hz per second. If the MINUTES switch is depressed, the minutes digit step the same way. Depressing the MINUTES and HOURS switches together steps the tens of minutes digit. The same thing happens to the timer counter if the TIMER SET switch is depressed and the HOURS and MINUTES buttons are depressed. For proper operation of the timer, the RESET button must be depressed on both the Timer, and the Power Control, if it is used, after the time and timer have been set. The RESET button will disable the TIMER OUTPUT. The EXT jack is a closed circuit type, and when a plug is inserted into it the clock will not reach the θ input on IC2.

A breakwire connected between the terminals on this plug will stop the count when the wire is broken. For instance, in a foot race, the breakwire is stretched across the finish line, and when the race starts, the RUN/STOP switch is moved to RUN, starting the count. When the breakwire is broken, the count will stop, indicating the elapsed time of the race. Photocells may also be used, (if properly conditioned to provide very low on resistance) to either make or break the circuit or both, across the EXT jack.

When using the unit as a control

timer, the power control is plugged into the TIMER OUTPUT, the time counter set to zero, and the timer counter set to indicate the amount of delay until the power control switches states.

To reset the power control, depress and RESET buttons on the Stopwatch and the power control. The TIMER OUTPUT from the Stopwatch will automatically reset itself one hour after it has triggered, and will trigger only once during a 24 hour period, unless the TIME or TIMER SETS are reset, even if the unit is set up for 12 hour operation.

The above mentioned time periods are valid only for a 50/60 Hz input clock. They will be 1/10th the value indicated if the clock is set at 500/600 Hz. The frequency of the MC1455 timer may be set with any one of several reference sources.

One way is to feed the signal from the timer into a frequency counter or to the vertical plates of an oscilloscope, with the 60-Hz line on the horizontal plates, and adjusting R3 for a square but stable Lissajous pattern.

CHU or WWV may also be used for a trial and error adjustment. If the crystal controlled time base is used, the most accurate possible adjustment will be by beating the 1 MHz signal against WWV. Have a good (timing?) time. **R-E**

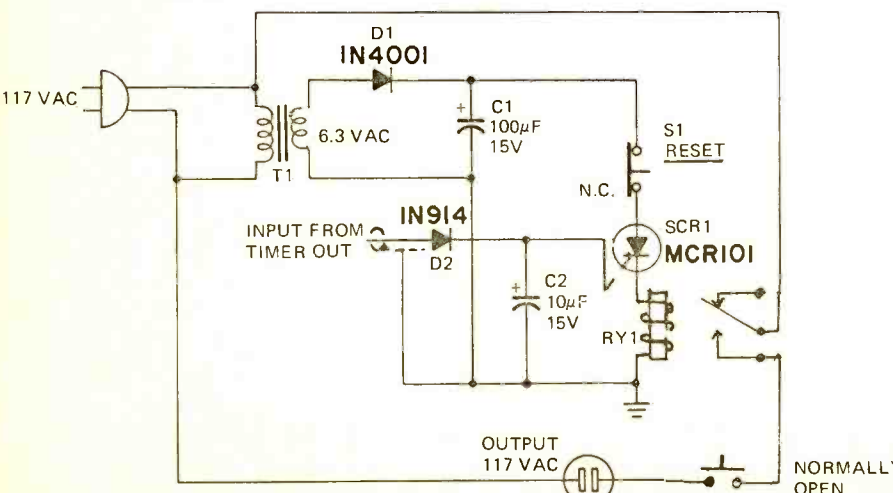

FIG. 10—REMOTE POWER UNIT enables remote triggering of the timer; both on and off.

PARTS LIST (AUXILIARY)

(Power Control)

- C1—100 μ F, 15V electrolytic
- C2—10 μ F, 15V electrolytic
- D1—1N4001
- D2—1N914
- RY1—6V relay, Sigma 25PA1
- S1—spst pushbutton N.C.
- SCR1—MCR101
- T1—primary, 117 Vac; secondary, 6.3 Vac (Power Line Time Base)
- R1—39,000 ohms, 1/4-watt 10%
- R2—47,000 ohms, 1/4-watt 10%
- C1—0.01 μ F, 15V
- D1—1N914
- T1—primary 117 Vac; secondary 6.3 Vac

(Crystal Time Base)

- R1—24,000 ohms, 1/4 watt, 10%
- R2—18 megohms, 1/4 watt, 10%
- R3—12 megohms, 1/4 watt, 10%
- C1—10 pF
- C2—trimmer, 2-40 pF
- IC1—AE5024-TB, Mostek MK5009
- XTAL1—1 MHz parallel resonant quartz crystal

(Tone Amplifier)

- R1—10,000 ohms, 1/4 watt, 10%
- C1—0.1 μ F, 15V
- Q1—MPS5172
- T1—Primary; 2000 ohms; secondary, 8-ohms; 8-ohm speaker

The following parts are available from Alpha Electronics, P.O. Box 1005, Merritt Island, Fla. 32952

- 6-V relay, 25PA1—\$2.85 PPD US
- MCR101 SCR—\$0.70 PPD US
- AE5024-TB IC—\$19.45 PPD US

4-Channel QS Matrix

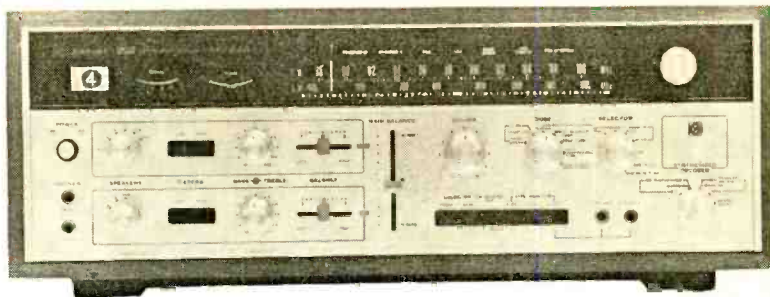

another road to 4-channel records

The race for universal acceptance of one 4-channel matrix stereo system is still being run all-out. You studied the SQ system in June; now here's the dope on QS

by LEONARD FELDMAN
CONTRIBUTING HIGH-FIDELITY EDITOR

Although the majority of matrix-encoded quadraphonic records sold in the United States are encoded using the SQ matrix system proposed by CBS (see *Radio-Electronics*, June 1973 page 44), acceptance of this matrix format is anything but world-wide. In Japan, in fact, the so-called "regular matrix", or QS matrix, is favored by several manufacturers and record producers.

The basic difference between the regular-matrix system and the CBS-SQ system arises from a fundamental difference in opinion as to what the ideal sound distribution field for four-channel reproduction should look like. CBS champions the idea that left-to-right channel separation should be maximized, and that front-to-back separation can be sacrificed in the process—or enhanced by means of gain-riding "logic" circuits.

Regular matrix proponents maintain that separation should be uniform from channel to channel around the entire sound field. Sansui, in particular, takes this "uniform" separation idea (originally proposed by Peter Scheiber in this country) and adds phase-shifting angles during the encoding and decoding process that provide apparent greater separation, but measurable separation is only 3 dB between any dominant channel and its two flanking channels. As we shall see presently, this uniform sound field idea also permits the use of a rather sophisticated form of enhancement logic which Sansui calls "Variomatrix".

The basic encoding formulas for the Sansui system are:

$$L_t = L_f + .414R_f + jL_b + j0.414R_b$$

$$R_t = R_f + .414L_f - jR_b - j.414L_b$$

Where L_t and R_t are the matrix-encoded left and right signals applied to the record groove, L_f , L_b , R_f and R_b are the left-front, left-back, right-front and right-back signals and $+j$ and $-j$ represent $+90^\circ$ and -90° phase angles respectively. If four equal amplitude signals (one for each of the four channels) are encoded at a given instant using these formulas, vector diagrams of the content of each of the two composite L_t and R_t signals appear as in Fig. 1. It is apparent that when such an encoded record is played on a

conventional stereo phonograph, both front and back left information are reproduced at full amplitude, while right-front and right-back are attenuated about 7.6 dB in the left speaker. The reverse is true for the right speaker.

Sansui decode matrix

The first and simplest form of Sansui matrix decoder used fixed matrix coefficients to yield the following:

$$L_f' = L_t + .414R_t$$

$$R_f' = R_t + .414L_t$$

$$L_b' = -j(L_t - .414R_t)$$

$$R_b' = j(R_t - .414L_t)$$

(Prime (') notations indicate that outputs are not, and can never be *identical* to the original input signals in any 4-2-4 matrix systems.)

If each of these matrix decode equations is solved in terms of the original four input signals, L_f , L_b , R_f and R_b the following output signals are obtained at the respective channels.

$$L_f' = 1.171L_f + .828R_f + j.828L_b$$

$$R_f' = 1.171R_f + .828L_f - j.828R_b$$

$$L_b' = 1.171L_b + .828R_b - j.828L_f$$

$$R_b' = 1.171R_b + .828L_b + j.828R_f$$

By "lowering the volume control" slightly to obtain unity coefficients for the desired or dominant signal outputs in each case, the results become:

$$L_f' = L_f + .707R_f + j.797L_b$$

$$R_f' = R_f + .707L_f - 1.707R_b$$

$$L_b' = L_b + .707R_b - j.707L_f$$

$$R_b' = R_b + .707L_b + j.707R_f$$

The symmetry of sound distribution inherent in this encode-decode approach is shown in Fig. 2. The asterisk (*) in each square of the diagram shows where the desired sound is supposed to be (e.g., front left) while the arrows indicate sound amplitude and phase for each of the four loudspeakers in each of the eight situations shown. In the case of the left-only desired signal we see that full amplitude of that signal is heard from the left-front speaker,

(continued on page 40)

CREI—the only home-study college-level training

and now

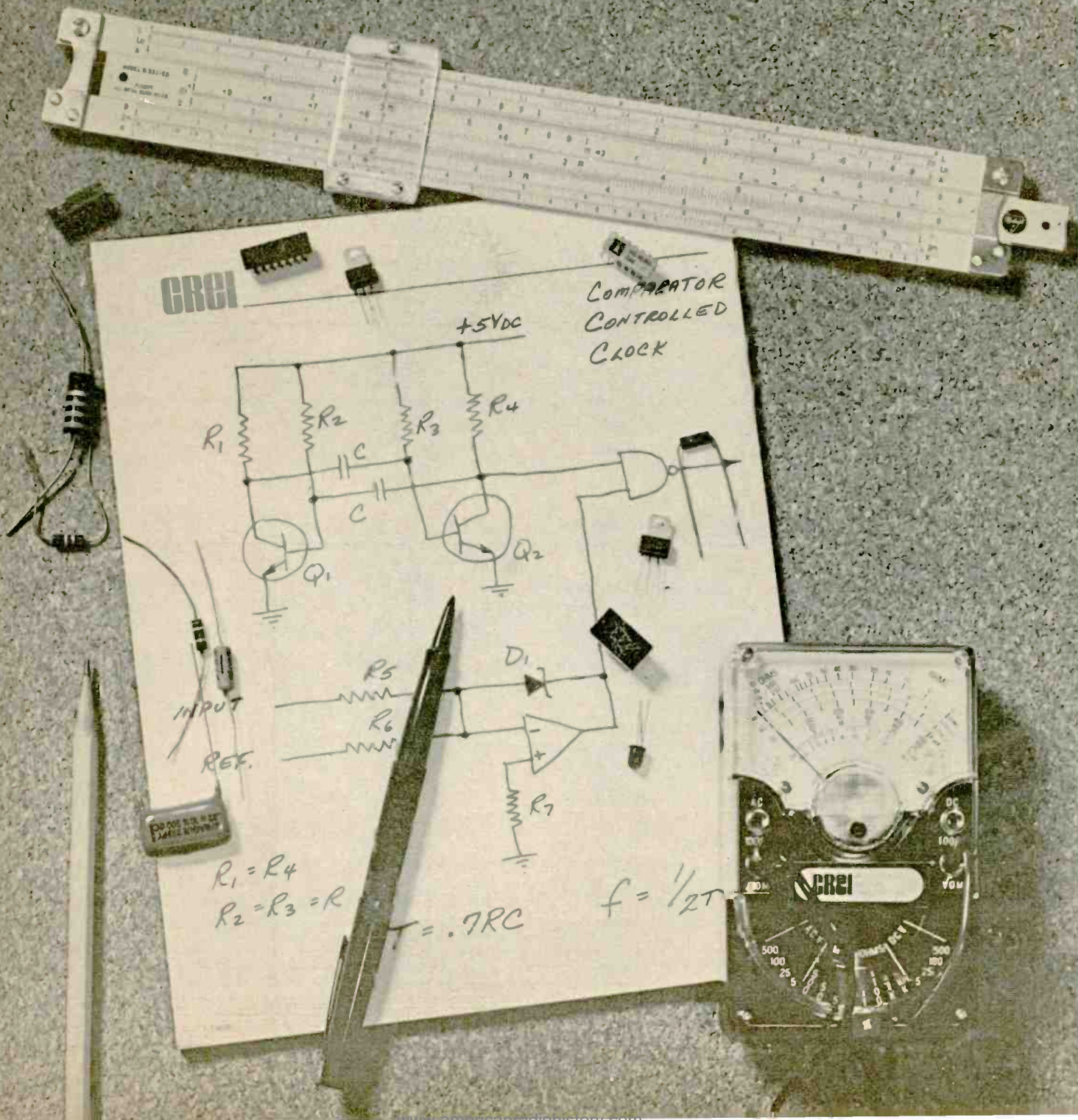

program which gives you in electronic circuit design

only CREI offers you a complete college-level Electronic Design Laboratory to speed your learning

Electronic circuit design—source of all new development in the application of electronics to new products and services. Without this skill, we would be unable to monitor the heartbeat of men in space. Without it, the computer revolution would never have occurred. And we would have yet to see our first TV show. *Yet, only CREI teaches electronic circuit design at home.*

ELECTRONIC CIRCUIT DESIGN

A key skill which paces our nation's progress in countless fields—from pollution control to satellite tracking to modern medicine to exploring the ocean's depths. And beyond. A skill which *you* must have to move to the top in advanced electronics.

CREI programs open up new worlds of opportunity for you.

In addition to electronic circuit design, CREI provides you with a full advanced electronics education in any of thirteen fields of specialization you choose. Communications, computers, space operations, television, nuclear power, industrial electronics—to mention just a few of the career fields for which CREI training is qualifying. With such preparation, you will have the background for a career which can take you to the frontiers of the nation's most exciting new developments. And around the world.

This free book can change your life. Send for it.

If you are a high-school graduate (or equivalent) and have previous training or experience in electronics, then you are qualified to enroll in a CREI program to move you ahead in advanced electronics.



Send now for our full-color, eighty page book on careers in advanced electronics. In it, you will find full facts on the exciting kinds of work which CREI programs open up to you. And full facts on the comprehensive courses of instruction, the strong *personal* help, and the professional laboratory equipment which CREI makes available to you. All at a surprisingly low tuition cost.

And when you have it, talk with your employer about it.

Tell him you're considering enrolling with CREI. He'll undoubtedly be happy to know you are planning to increase your value to him. *And he may offer to pay all or part of your tuition cost.* Hundreds of employers and government agencies do. Large and small. Including some of the giants in electronics. *If they are willing to pay for CREI training for their employees, you know it must be good.*

Send for Advanced Electronics today. You'll be glad you did.



CREI Dept. E-1411D
3939 Wisconsin Avenue
Washington, D.C. 20016

Rush me your FREE book describing my opportunities in advanced electronics. I am a high school graduate.

Name _____ Age _____

Address _____

City _____ State _____ ZIP _____

If you have previous training in electronics, check here

Employed by _____

Type of Present Work _____

Veterans and servicemen, check here for G. I. Bill information

www.americanradiohistory.com

CREI

**CAPITOL
RADIO
ENGINEERING
INSTITUTE**

WASHINGTON, D.C. 20016

while the left-back and right-front speakers reproduce the same signal at an amplitude reduced by 3 dB. The diagonally opposite channel produces *no* output ("infinite" separation) whenever a corner-only signal is to be reproduced.

Because only those speakers which flank the desired speaker are operating under the "corner"-only conditions, the listener's attention is further focused towards the desired source of sound. As a result, this simple dematrixing can produce a fairly satisfactory four channel illusion despite the minimal separation figures. It is, in fact, the same separation obtained with the CBS-SQ system when that

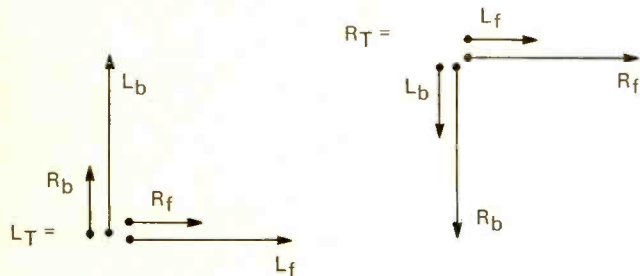

FIG. 1—VECTOR REPRESENTATION of Sansui encoded, left and right composite 4-channel matrix signals when the amplitude of all four signals is equal.

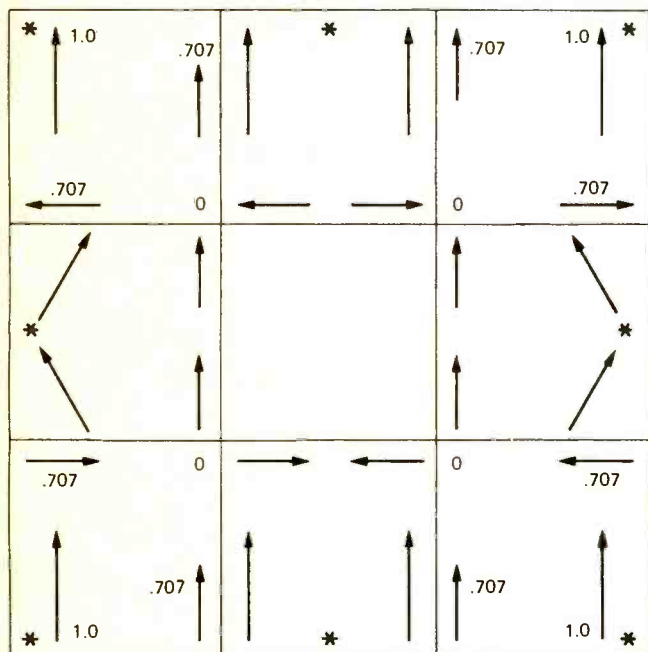

FIG. 2—SIGNALS PRODUCED IN THE SIMPLE Sansui QS system when original signal desired is as indicated by the asterisk (*) in each of the eight conditions shown.

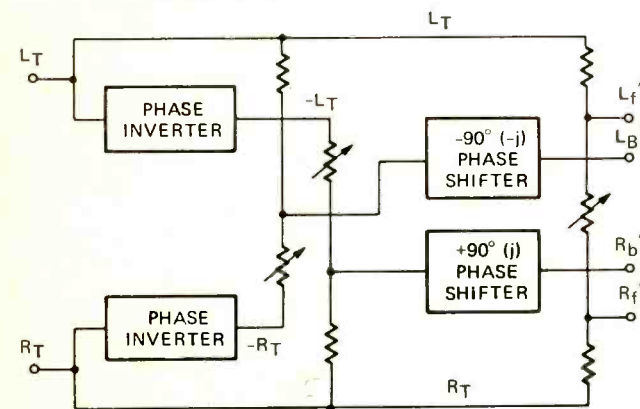

FIG. 3—BASIC CIRCUIT ELEMENTS required for QS simple matrix decoding.

system is decoded by only a simple matrix. The difference is that cross-talk in the QS system appears at flanking speakers, whereas cross-talk in the SQ system appears in a diagonally opposite speaker and a speaker along the same wall (left or right) as the desired sound.

A simplified diagram of the basic Sansui decoding matrix circuit is in Fig. 3. Here the necessary phase inverters (to provide "minus" signals) and phase shifting networks (to provide the required $\pm j$ factors) are shown in their appropriate positions in the signal paths. The potentiometers shown establish the correct coefficients (in this case, 0.414) required by the matrix decode equations shown earlier.

Introducing the Variomatrix

Not too long after Sansui introduced this simple matrix decoder, they followed up with a decoding technique called *Variomatrix*.

Suppose, for the moment, that only a left-front and right-front signal are being encoded, and that each has an amplitude of 1. The encoded signals will consist of:

$$L_t = L_f + .414R_f; R_t = R_f + .414L_f$$

If we were to add these two signals together ($L_t + R_t$) and add to that total the *difference* between the two signals, we obtain:

$$(1.414L_f + 1.41R_f + (.586L_f - .586R_f)) = 2.0L_f + .828R_f$$

Instead of 3 dB of difference between the two signals, we now have over 7.6 dB of difference or separation. Taking it a step further, if we add to the sum of the two composite signals 2.41 times the *difference* between the two signals, we obtain:

$$(1.41L_f + 1.41R_f) + 2.41(.586L_f - .586R_f) = 1.41L_f + 1.41R_f + 1.41L_f - 1.41R_f = 2.82L_f$$

The output from the L_f channel now contains *only* an amplitude of L_f , with the original crosstalk from R_f *cancelled out* by the choice of the coefficient, 2.41. Of course, we have oversimplified the situation by stipulating only L_f and R_f signals at this instant (no back signals) but it should be clear that under these circumstances, it would be equally possible to obtain a cross-talk free R_f signal in the right speaker—this time by *subtracting* 2.41 times the difference between these L_t and R_t encoded signals from the sum of these same two signals. If there were back signals present during this experiment, applying the 2.41 coefficient would increase their intensity in the *front* channels beyond that of the desired signals. However, if there were some way to vary this coefficient over a wide range, depending upon whether signals predominated in front or back, it would be possible to instantaneously impart greater separation to each of the channel outputs on a continuously variable basis.

That's where the name Variomatrix comes from. Instead of having fixed coefficients built into the decoder, these matrix coefficients are made to vary by sensing whether the dominant signal is towards the front or towards the back. In the example cited, if the situation had been reversed and sound was supposed to predominate at the rear (either left or right rear), the 2.41 coefficient would have had to approach zero, and another matrix coefficient, used to extract back left or back right information would have had to approach 2.41. This time we would be dealing with an L_t signal consisting of $jL_b + j.414R_b$ and an R_t signal consisting of $-jR_b - j.414L_b$ and, if we desired a pure L_b' signal we would matrix as follows:

$$(L_t - R_t) + 2.41(L_t + R_t), \text{ or} \\ (jL_b + j.414R_b + jR_b + j.414L_b + j2.41L_b + jR_b - j2.41R_b - jL_b) = j2.82L_b$$

Again, if it were a right-back signal that were dominating, the formula for decoding would have applied the 2.41 coefficient in the equation

$$R_b' = (L_t - R_t) - 2.41(L_t - R_t)$$

and when this equation is expanded in terms of the origi-

nal L_b and R_b contributions, the results would have been $j2.82R_b$.

Phase sensing is vital

The unique feature of the Variomatrix idea is that it uses phase information rather than amplitude information to determine what the various matrix coefficients shall be. Because of the particular encoding equations used in a QS Regular Matrix system the front-back ratio is directly proportional to the difference in the phase angle of the L_t and R_t signals. This phase difference is plotted in Fig. 4 and is equal to 90° when front-back amplitude ratio is one-to-one, and approaches 180° when the back-to-front ratio approaches infinity (all sounds at the back, no sounds in the front channels).

The block diagram in Fig. 5 shows how this phase comparison is used to alter the matrix coefficients for the front and back matrix networks. L_t and R_t signals are applied to a phase discriminator (after limiting). The outputs of the phase discriminator are fed to gain control amplifiers which vary the contribution of the $L_t - R_t$ signal, in the case of the front matrix; and the $L_t + R_t$ contribution in the case of the back channel matrix. The actual QS decoders being marketed today allow the coefficients to vary between 0.3 and 2. With this much variation available, a left-front signal, encoded using Sansui Regular matrix parameters can be reproduced from the left front speaker with cross-talk in the remaining speakers reduced to the amounts shown in Fig. 6.

Multiple signals

The examples we have shown up to this point involve applying a single signal to the encoding process. Under musical conditions, of course, two, three or all four channels may be called upon to reproduce different sounds at the same time. Thus, under actual musical conditions, the matrix coefficients change from moment to moment with a time constant of approximately 10 ms. Sansui claims. This time constant helps mask sound directionality while at the same time improving instantaneous inter-channel separation. Obviously, if two or more signals dominate the sound field equally, the Variomatrix's nominally high separation capability must be compromised, and the way in which separation capability varies as front-back ratio changes is illustrated in Fig. 7.

The vertical axis of the graph indicates the signal level at the four output terminals of the decoder with a 1-kHz signal fed into the L_r input of the encoder. At the same time, a 3-kHz signal of varying level is fed into the L_b input of the encoder. Since the QS matrix in both encoding and decoding is rotationally symmetrical, only the separation of the L_r channel is measured in relation to the other channel. A plot referencing other channels would produce the same results.

The horizontal axis of Fig. 7 shows the ratio between

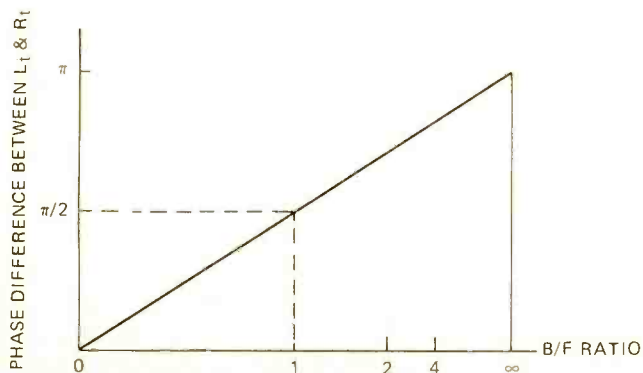

FIG. 4—PHASE RELATIONSHIP between QS encoded L_t and QS encoded R_t .

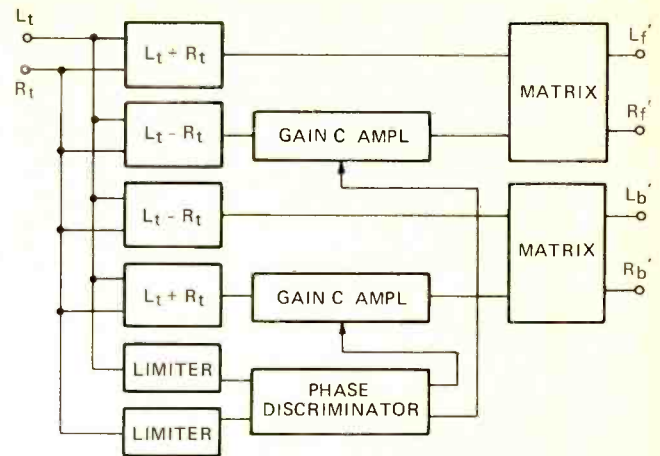

FIG. 5—BLOCK DIAGRAM OF QS Variomatrix decoder.

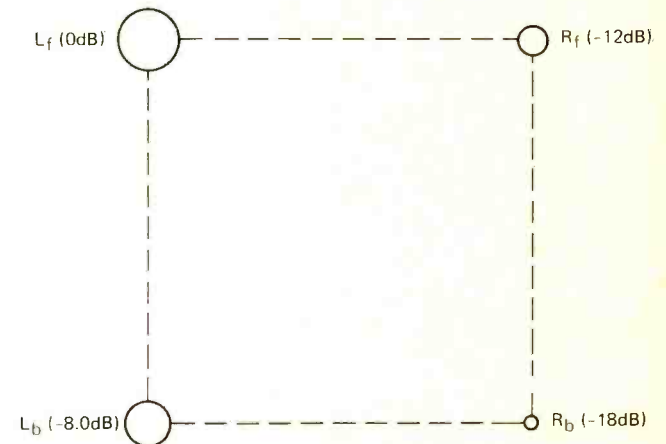

FIG. 6—DECODER OUTPUTS FROM EACH SPEAKER for an L_f signal, when front and back variable matrix coefficients are varied over the range from 0.3 to 2.0.

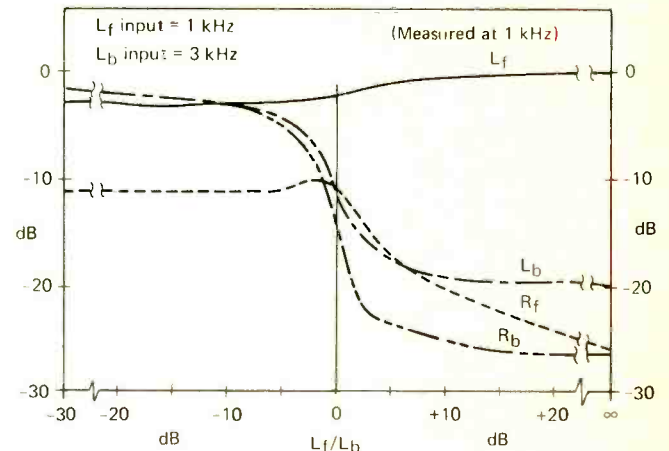

FIG. 7—SEPARATION OF A LEFT-FRONT SIGNAL as a second signal (L_b) is added in Variomatrix decode system

the signal levels fed to the L_r and L_b terminals of an encoder. The right hand region of the graph is where the L_r signal is larger than the L_b signal. The left hand region is where the L_b input is greater than the L_r signal. From the graph we note that when only the 1-kHz L_r signal is applied, there is at least 20 dB of separation as far as the other three speakers are concerned. As the 3 kHz signal is fed with increasing amplitude to the L_b encoder input channel, it gradually causes reduced separation between the L_r program heard over the correct speaker and the amount of L_r heard from the other three speakers. When the L_b signal reaches the same level as the L_r signal, remaining

(continued on page 90)

How Active Filters Work

Here are full details on how to build filters with op-amps instead of inductors. This stable and reliable method works for practically all audio and sub-audio low-pass, bandpass, and high-pass designs

by DON LANCASTER

FOR YEARS, PEOPLE WORKING ON CIRCUIT theory have been trying to do-in the inductor. This is especially true in the audio and sub-audio regions where inductors are inherently big, expensive, difficult to adjust, and subject to fields and hum pickup. After a lot of false trys and some rather poor ways of going about this, a batch of solid, reliable methods now exist that can do the job. Almost all these methods use low cost, readily available operational amplifiers. In most of the methods, the energy storage of an inductor is simulated by taking energy from a power supply and delivering it at the right point and in the right amount in a circuit to simulate exactly the behavior of an inductor.

Actually most methods don't work directly on replacing inductors. Instead, they look at the whole picture and attempt to come up with a functionally equivalent circuit that does exactly the same thing that the original one did, but internally does it in a wildly different way. These functionally equivalent circuits are often called active filters, and an active filter is simply any circuit that uses at least one operational amplifier or its equivalent to simulate exactly a circuit that normally would need at least one inductor to get the same result.

A filter itself is any frequency selective network. Three popular styles are the low-pass filter that passes only low frequencies and stops higher ones; the bandpass filter that passes only a few or a range of median frequencies; and a high-pass filter that allows only high frequencies to reach its output. A rumble filter on a turntable is a high-pass filter. The tuning on an AM radio is a bandpass filter, and the treble cut control on a hi-fi is a form of low-pass filter.

A comparison

Before we go into the nuts and bolts details of how to build your own active filter, let's compare a simple active low-pass filter with an equivalent low-pass passive one (see Fig. 1). And, if we wanted to, we

tance decreases as we increase frequency, shunting more and more signal to ground. In the active filter, we essentially have two cascaded R-C sections at very high frequencies that also shunts the signal to ground. The problem is that if we left the amplifier out of the circuit, the response would droop very sloppily and very badly around the cutoff frequency.

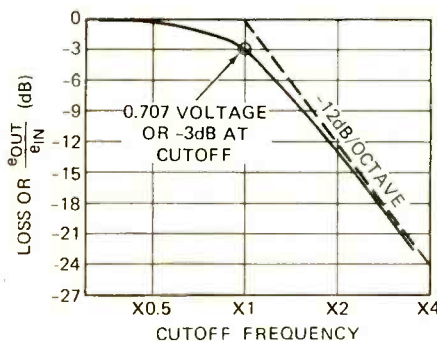

FIG. 2—RESPONSE OF LOW-PASS FILTER. Slope shown is 12 dB per octave.

What the op amp does is use circuit feedback via C1. It takes energy from the supply and introduces it in the middle of the R-C network to simulate exactly the same effect as energy storage in the inductor. Thus no R-C network by itself can ever hope to be as good as an L-C one, but an R-C network with some energy feedback controlled by an op amp is another story, and you can replace virtually any L-C network with a group of op amps, resistors, and capacitors. In fact, there's even things you can do actively that you can't with conventional circuits. Gain for instance.

We picked this particular response because it has the maximum possible flatness in the passband. It is called a Butterworth filter. If we try to steepen the response without adding any more parts, we'd get a hump in the passband, and the size of the hump would decide the initial but not the ultimate rate of falloff. Filters with humps are called Chebycheff filters if the humps are in the passband and Elliptical filters if the humps are both in the passband and the stopband. We could also make the response less flat and more gradual. This would improve the pulse response and overshoot at the expense of tilt in the passband and a more gradual rolloff. The

best of these is called a Bessel filter. The term that controls the shape of the filter near the cutoff frequency, but not at very low or very high frequencies is called the damping of the filter. The damping is controlled by the L/C ratio in the passive filter and the C1 to C2 ratio in the active filter, or by holding C1 and C2 constant and changing the ratio of R3 and R4.

We picked the Butterworth here because it is the most popular and the easiest to use. We'll stick with Butterworth filters all the way through this story. Other types are just as easy to build. All you have to do is move the damping and cutoff frequencies around a bit.

If we wanted something steeper than a 12-dB-per-octave rolloff, we'd have to add more parts. Two inductors and a capacitor would give you a 18-dB-per-octave filter, and two inductors and two capacitors would give you a 24-dB-per-octave rolloff, and so on. We call this the order of the filter. Second-, third-, and fourth-order filters have rolloff rates of 12, 18, and 24-dB-per-octave, and are the most popular normally used. Normally it takes one op amp for a second or third-order filter and two for a fourth.

Note that the damping of the filter controls the response near cutoff, particularly the flatness in the passband, the time delay and overshoot, and the initial rate of falloff. The order of the filter controls the ultimate or asymptotic rate of falloff for the filter.

Why go active?

The operational amplifier serves as a gain block with a very high input impedance and a very low output impedance. Its essential function is to provide for energy feedback to simulate the effect of energy storage in an inductor. Two nice benefits are the ability to drive any load and to use higher impedance (and almost always cheaper) components. So what are the benefits of an active filter? What do we gain and what do we lose when we go active?

The first and obvious thing we lose is the inductor, along with its cost, size, difficulty of adjustment, and sensitivity to hum and other magnetic fields. Note also that the passive filter has a load resistor. The value of this resistor is critical, for if you change it, the relative effects of the reactance changes of the inductor and capacitor

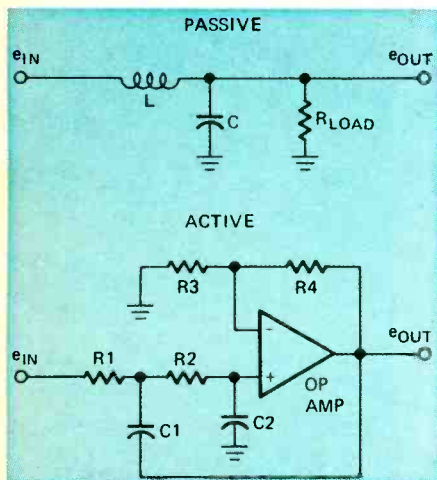
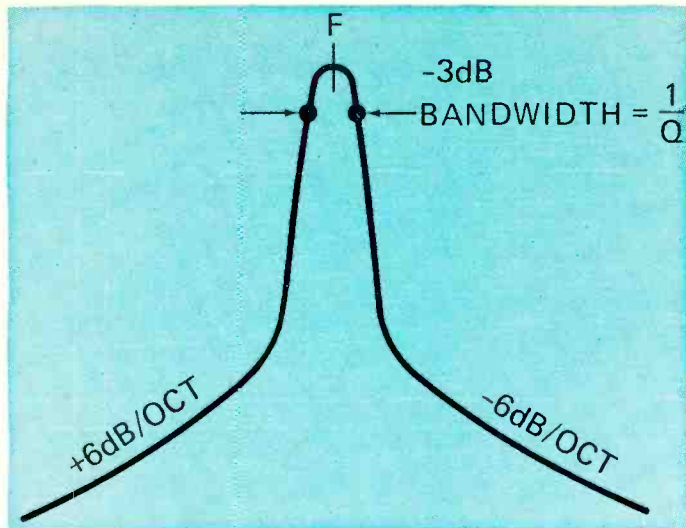

FIG. 1—LOW-PASS FILTERS. The passive L-C type is simpler, the active is more versatile.

could select the L-C ratio of the passive filter or the ratio of C1 and C2 in the active filter to get a response that looks like Fig. 2.

The way we get the response differs for the two circuits, but the result is the same. In the passive filter, the inductive reactance increases and the capacitive reac-



change and the response shape or the cut-off frequency may change. This is not true of the op amp active filter, for the op amp can drive most any reasonable load without changing the filter's response. We can vary the load from an open circuit down to anything the op-amp can reasonably drive without changing the response.

The input to the op amp is a very high impedance. This means you can use high-impedance resistors and capacitors for a given response at a given frequency. The benefits here are obvious. A high-impedance resistor costs the same as a low-ohms one, but a high-impedance capacitor is much smaller, and much cheaper.

Passive filters are inherently lossy, and the best we could expect to hope for would be slightly less than unity gain. With op amps and active filter designs, you sometimes can design for any circuit gain you want. Those we're going to show you have gains above unity.

Another big benefit is tuning. Large variable capacitors are nonexistent, while large variable inductors are expensive and a pain to adjust. On the active side, we have resistors R1 and R2 and surely changing them will change the response. For this particular circuit, we have to change *both* at once to change frequency without hurting the damping and response shape. This is easy to do with a dual pot, and we can easily get at least a 10:1 range. Even for slight tuning adjustments, the resistors are easy to change to get exactly the response you need. Because of this, active filters are generally more tuneable and easier to adjust than passive ones.

A final benefit is a bit subtle, but very important when we want a fancier higher order filter with faster cutoff slopes. We can *cascade* active filter blocks without any interaction, since they are free from fields and mutual inductance and since they generally have a high input impedance and a low output impedance. Cascadeability is a very big benefit. You normally can't simply cascade identical stages, for what was a -3dB point becomes a -6 and so on. What you do is take the math expression for the higher order filter you want and *factor* it into second-order terms, and then build each second-order term separately. Generally, the individual block responses will be less damped and appear peaked when compared to the final result.

Disadvantages and problems

If active filters are so good, why doesn't everybody use them? First and foremost, it's because very few people understand or appreciate what they are and what they can do. But, over and above this, there are some limitations and disadvantages to their use. Let's take a closer look.

Obviously, we need some supply power and the noise characteristics of the op amp can effect very low-level signals. More important is the high-frequency limitations of the operational amplifier. As you increase operating frequency, an op amp's open-loop gain decreases and its phase characteristics change so that you are limited to the upper frequency you can handle with a given operational amplifier.

For amplifiers like the 741 style or its dual and quad combinations, a reasonable upper frequency limit for active filters is between 20 and 50 kHz for low-pass and high-pass versions, and between 2 and 5

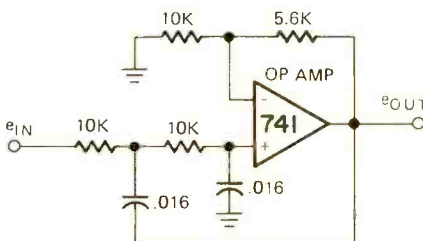

FIG. 3—ACTIVE FILTERS HAVE GAIN. Passive types are lossy circuits.

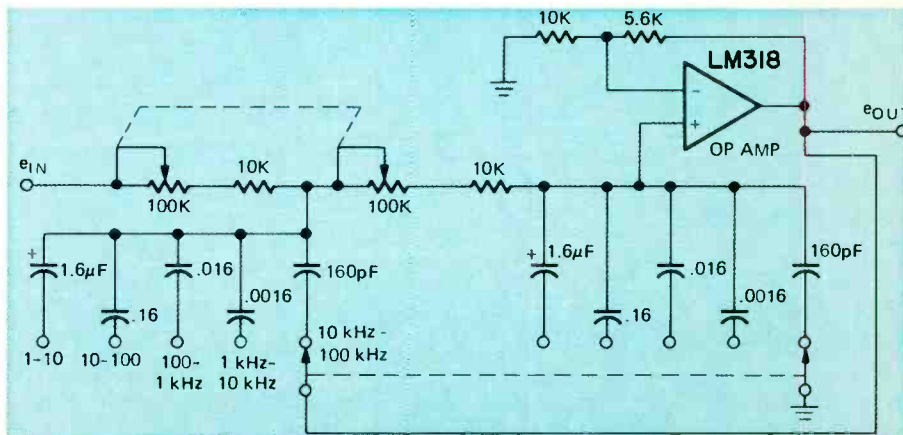

FIG. 4—AN ADJUSTABLE LOW-PASS FILTER covering from 1 Hz to 100 kHz in five frequency ranges. Switched capacitors select the bands, ganged potentiometers do the variable tuning.

kHz for bandpass designs. If you go to a higher performance internally compensated amplifier such as the *National* LM318, you can work up into the hundreds of kilohertz. Finally, if you go to really exotic op amps you can work higher, and even microwave active filter structures have been built. Thus, we have an upper audio limit for active filters built with the cheapest available op amps and a fractional megahertz limit for op amps in the \$3 to \$5 class.

Bandpass filters need more gain for resonance and thus are generally limited to lower frequencies. One way around the problem is to distribute the problem among two or more op amps so that each only has to provide some of the gain.

The low-frequency limit is another story. It's decided mostly by how much you want to pay for big capacitors and how high you're willing to let impedances get. With FET op amps, this can be a bunch, and operation down below 0.1 Hertz is certainly possible. Thus active filters are ideal for such sub audio work as brain wave research, seismology, geophysics, and fields like this.

One limitation, and the big one, is called the *sensitivity* problem. You have to ask how the individual components in the active filter are going to change the response if they are out of tolerance or drift with time. For instance, if a particular parameter such as a gain or a capacitance value happens to have a sensitivity of 0.5, the result is a 5% change in cutoff frequency or damping for a 10% change in component value. On the other hand, if a 1% variation makes a 50% change in something you've got problems. This is clearly ungood. When picking a way to build active filters, you have to be aware of the sensitivity problems and how to use them. The method we'll be showing you in a minute is very well behaved at fixed low gains and for lower to moderate Q bandpass designs.

A final limitation is one of method. There are about a dozen good and proven ways to design active filters. These all vary with their ease of understanding and what they can and cannot do. Some can't handle all three basic responses. Some allow single resistor tuning; others allow separate tuning of bandpass gain, center frequency, and Q. Some are well behaved at certain gains, but at others are too highly sensitive or actually unstable. You have to pick a method that works for you, is reliable, behaves well, and

does what you want it to. The one we'll be showing you is very easy to understand, stable and forgiving of component variations for fixed low gains, and useable in the bandpass case for low to moderate Q's. It usually takes two resistors simultaneously adjusted to tune, and in the bandpass case, you cannot separately set the Q, gain, and center frequency without a major change in components.

The method is called the *Sallen-Key* or Voltage Controlled Voltage Source (VCVS) method, and first appeared in the March 1955 *IRE Transactions on Circuit Theory*. Other popular filter methods are called the *Integrator Lag*, the *Biquadratic Section*, the *Multiple Feedback*, and the *State Variable*. Another type of active filter uses the *gyrator* or *impedance converter* but these generally take a bunch of parts and have a high-impedance output.

Building your own

So, now we should know *why* we'd want to use active filters, and *where* to go to get complete design details, let's concentrate on *how* to actually build one. Here's a second-order Butterworth low-pass filter with a cutoff frequency of 1 kHz and a gain of 1.6 (see Fig. 3).

The response is identical to the curve in Fig. 2 with $f=1$ kHz, $2f=2$ kHz, and so on. As with any low-pass active filter, there must be a low dc impedance to ground at the source. Thus your source has to be less than 10,000 ohms and must provide a route to ground for the op amp's bias current. Again, the response is Butterworth, giving us the flattest possible passband, and an attenuation of -3 dB or 0.707 amplitude at the cutoff frequency, and smoothly falls off at -12 decibels per octave. This means that in the stopband as you double frequency, you get only one quarter the amplitude, and so on.

The above circuit looks deceptively simple and it is except, that a "magic" gain of 1.6 has been used that lets you use equal resistors, equal capacitors, and still have the desired shape. Change anything from the above, and the mathematics behave wildly. The circuit is forgiving of component variations and 5% components should be more than adequate for practically all uses.

To change frequency (in Fig. 1) you change R1 and R2 to identical values, or you simultaneously change C1 and C2 to new values. Raising R lowers the operating frequency. Raising C lowers the operating frequency. Thus, a 5000-ohm value instead of 10,000 ohms puts you at a 2 kHz cutoff frequency, and so on. A 0.032 μ F capacitor value puts you at 500 hertz and so on. If you change one capacitor, you *must* change the other. Similarly if you change one resistor, you *must* change the other, or the response shape will also change.

It's easy to see how we can use a dual pot to tune 10:1 and switch capacitors to get decade ranges. Fig. 4 shows a circuit that covers any cutoff frequency you want from 1 hertz to 100 kHz:

The pot rotation will generally be non-linear since the frequency varies inversely with pot rotation and resistance value. One way to linearize the pot is to use a dual audio log pot, with a normal taper if the dial is on the pot shaft and a reverse taper if the dial is on the panel.

If you just want one frequency differ-

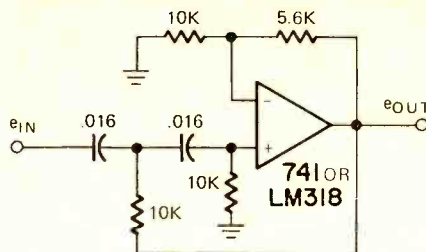

FIG. 5—IN HIGH-PASS FILTERS, the R and C shunt and series elements are transposed.

ent from 1 kHz, just calculate the capacitor value you need and change the capacitors, or change the resistors. It's simply the ratio of the capacitors equals the ratio of the frequencies and vice versa for the resistors.

High-pass designs

The high-pass filter is a snap—you inside the circuit out and by a network principle called *duality* you're done. Fig. 5 is a 1-kHz Butterworth, second-order high-pass circuit.

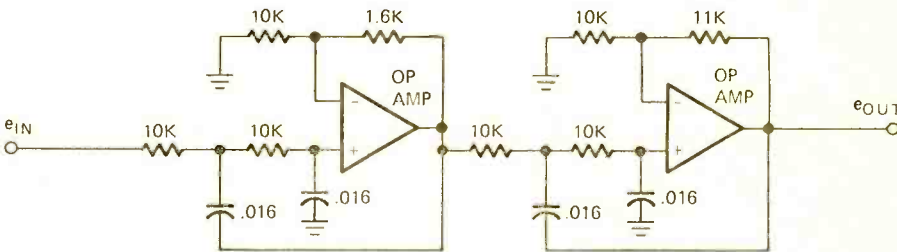
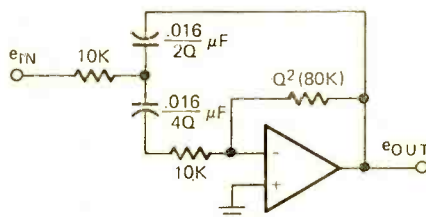
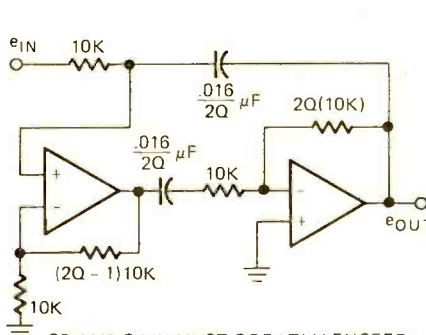

FIG. 6—TWO LOW-PASS SECTIONS IN CASCADE produce a fourth-order Butterworth filter with a rolloff slope of 24 dB per octave. The circuit's overall gain is about 8 dB.



OP AMP GAIN MUST GREATLY EXCEED $8Q^2$ AT OPERATING FREQUENCY
CIRCUIT GAIN = $2Q$



OP AMP GAIN MUST GREATLY EXCEED $2Q$ AT OPERATING FREQUENCY
CIRCUIT GAIN = $2Q$

FIG. 7—ACTIVE BANDPASS CIRCUITS require high-gain operational amplifiers.

You simply interchange the resistors and capacitors on the input and you now have a highpass circuit. Again, if you change frequency, change both resistors or both capacitors to identical new values, or else the response shape will also change.

We can now see another big advantage to the "magic" gain value of 1.6—this circuit lets us switch from highpass to lowpass with a 4pdt switch without any change of component values.

Steeper skirts

We can cascade two low-pass second-order sections to get a fourth-order Butterworth with a 24-dB-per-octave cutoff. We can't use identical sections, but we can make everything identical except for R4 (the feedback resistor) on each section. Finding the right R4 takes a lot of math, but here's the final circuit (see Fig. 6). It has an overall gain of 2.5:

The response is twice as good as before on a decibel scale. The passband is twice as flat and still drops only to -3 dB at the cutoff frequency of 1 kHz. The attenuation drops at 24-dB-per-octave, meaning that every doubling of frequency gives you only one-sixteenth the power and so on.

The higher performance circuit is somewhat harder to tune, since you simultaneously have to change four capacitors or

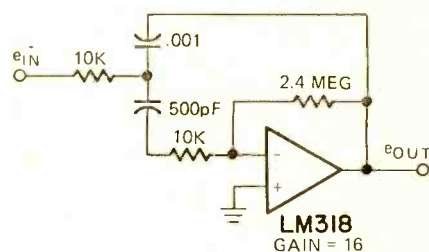

LM318
GAIN = 16

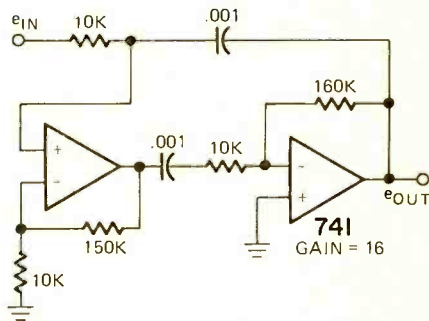

741
GAIN = 16

FIG. 8—CIRCUIT CONSTANTS for bandpass circuit where Q is 8 and frequency is 1 kHz.

four pots. Quadriphonic audio pots are a neat way to handle the tuning and they are reasonably available. Highpass to lowpass switching can be handled by a 8-pole-double-throw switch or two ganged 4-pole-double-throw pushbuttons, arranged so one is up when the other is down and vice versa.

Other orders and shapes of active filter
(continued on page 71)



Careers in Electronics

The high-school graduate has countless opportunities in electronics open to him. Here is a brief look at just a few of them

by JAMES A. GUPTON

"THE EAGLE HAS LANDED . . ." ACROSS 250,000 miles of space, from a spacecraft in orbit around the moon, came the voice of Michael Collen, July 20, 1969, to announce the successful landing of the first man on the moon. Within hours, the world saw and heard Neil Armstrong step from the ladder of the LM onto the surface of the moon and say, "That's one small step for man, one giant leap for mankind."

For centuries, man has dreamed about making the journey from earth to the moon. The dream began long before the dawn of the science of electronics. Yet it was electronics that made this journey possible. It was electronics that navigated the spacecraft through uncharted deep space, monitored the life support equipment and the physical health of the crew, controlled everything from launch to landing of the spacecraft and maintained the voice and television com-

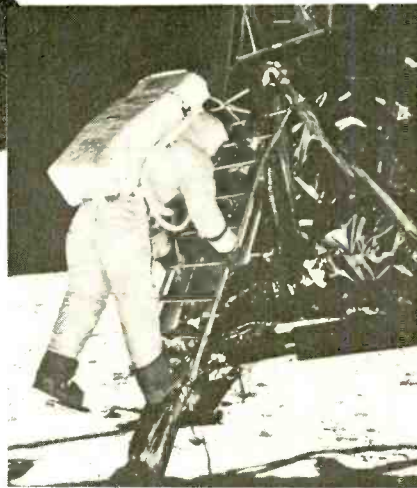

EDWARD ALDREN CLIMBING down the ladder of the Lunar Module to walk on the moon.

munications between the moon and earth.

This fascinating science of electronics is just under 70 years of age, but it is still in its infancy. Millions of new jobs will be created in electronics during the next decade. There will be a new super technician—the Engineering Technician—who will rise from the ranks of the nation's high school graduates.

The Engineering Technician will be in great demand. He will outnumber scientists and engineers by a ratio of 3:1. His job: be the "right arm" in research in the physical sciences, and in medical electronics. The Engineering Technician is no dream. He is real, he exists and his numbers are increasing daily.

Every year our public and private high schools graduate more than 2 million seniors. Most don't continue on to college, many who do never complete the requirements for graduation. These 1.5 million young men and women are potential Engineering Technicians. They are needed in home entertainment, in broadcast engineering and in all of communications. Many will find electronic careers in the military, still others will qualify for electronic careers in state and federal agencies.

Becoming an Engineering Technician is not easy. Formal education

JUNIOR COLLEGES offer academic credits to those who wish to pursue their education to earn a college degree. Photo courtesy Gaston County Junior College, Gastonia, N. C.



ELECTRONIC LOGIC and computer technology courses can be taken at many junior colleges. Here's a look at the computer lab at Gaston County Junior College.



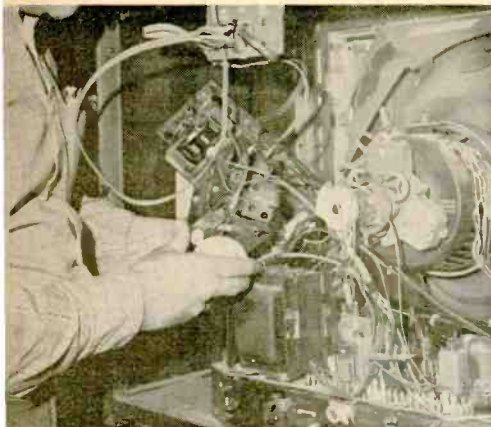

COLOR TELEVISION TECHNICIANS learn through correspondence courses. Photo, Quality Television Service, Charlotte, N. C.

in electronics and years of on-the-job training to develop engineering experience are necessary. The technician, too, must acquire a good background in basic electronics before he can seek employment in his chosen field. However, getting your electronic training may be much easier than you expect. Let's explore some of the training possibilities available to the high school graduate.

Public school adult education

Over the years, high schools have launched programs for adult education. Here one can complete requirements for a high-school diploma or attend part-time night classes to expand your knowledge and skills in trade courses.

Basic electronics and specialization in radio and television receiver repair lead the list for most public adult education programs. Usually given three nights a week, these basic electronic courses require approximately nine hours a week for 39 weeks. Generally, these courses parallel the normal school year. Your basic training may be no further away than

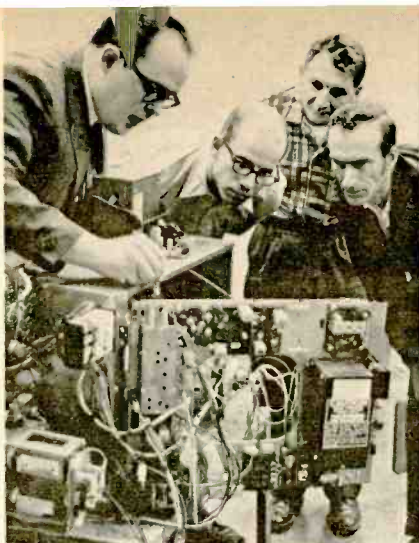

THERE ARE NO ENTRANCE EXAMS or age barriers with correspondence school training. Courtesy Bell & Howell Schools

your nearest high school.

Technical education centers

Technical education began to develop in the early 1960's when many states created special technical education agencies. Their multi-county sponsored technical centers have often become junior colleges awarding associate degrees in applied science. Like high-school adult programs, the technical education centers offer both technology and trade courses.

In electronics, your degree pro-

VIDEO TAPE recording is one of the latest innovations in broadcast television. Photo courtesy TV station WBTV, Charlotte, N. C.

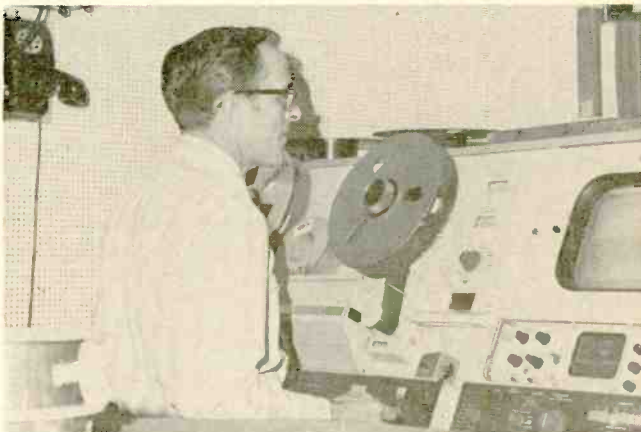

TWO-WAY RADIO TECHNICIANS require an FCC license to perform their precision work. Courtesy Two-Way Radio, Charlotte, N. C.

grams will require two years of study on a full-time basis or four years part-time. The trade programs usually run 12 months for full-time students and two years for part-time students.

Military schools

If you are classified A-1, you should consider one of the military electronic schools. The Dept. of Defense, which combines all branches of our military forces, lists over 40 military schools that train enlisted men in some form of military electronics.



THIS RADAR will not net you a traffic ticket . . . It guides your plane to a safe landing. FAA Approach Radar Control, Douglas Municipal Airport, Charlotte, N. C.

AIR TRAFFIC control is under the FAA. Only the very best electronic technicians are entrusted with the safety of air line passengers. FAA Control tower at Douglas Municipal Airport Charlotte, N. C.



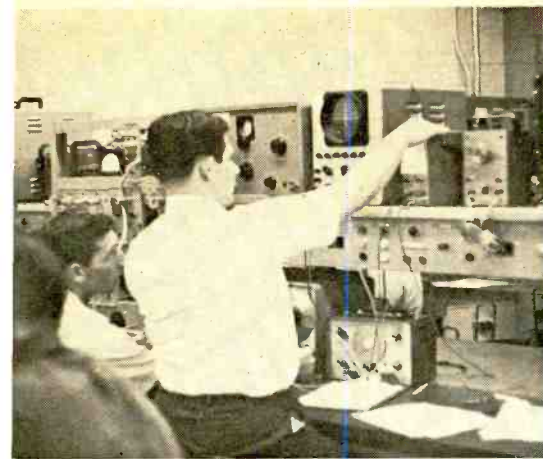

ELECTRONICS STUDENTS In lab at Florence-Darlington Tech. Ed. Center, Florence, S.C.

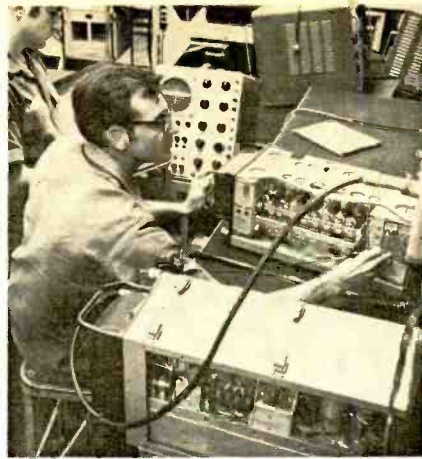

AIR FORCE RADIO service technicians at work on airborne radio gear. USAF photo.



AT FLIGHT STATIONS for training as fleet replacement flight crew. U.S. Navy Photo.

Graduates get well-paying and challenging positions, along with world-wide travel. Guided missiles, nuclear ships, radar, air-traffic control and television broadcasting are just a few of the many electronic careers available through these schools.

Junior colleges

Here, also, one can earn an associate degree in applied science in two academic years as a step towards becoming an Engineering Technician. You may later transfer to a full-scale

Completion and become eligible to take city, county or state journeyman license examinations.

Correspondence schools

Another semi-formal approach for the graduate who does not have the time for formal education in electronics is a correspondence school. This type of training requires a strong-minded individual who can drive himself on.

Correspondence courses offer the same basic electronic knowledge as

more formal education programs; they lack only classroom discussion. Their laboratory practice is probably superior because you must assemble each lesson from parts while more formal schools have their students perform experiments on prefabricated plug-in modules.

A correspondence course requires 12 to 24 months to complete, depending on the time you have available. One school graduates over 5,000 students each year, which shows the popularity of this kind of training.

Which electronics technician schooling is the best? It depends on you. No school has a magic funnel to pour knowledge into you. Remember that the super technicians of today and tomorrow will come from high school graduates who prepare themselves for success. Even today there is a drive on to elevate the electronic technician to Engineering Technician. The Institute for the Certification of Engineering Technicians, striving to make the technician an ever more valuable member of the engineering team, recognizes three levels or grades of Engineering Technician: (1) the Associate Engineering Technician, (2) the Engineering Technician, and (3) the Senior Engineering Technician. Age, training, and experience are the criteria for the various grades.

Warning: when experience alone is the qualification for certification, the applicant must have the endorsement of three professional engineers and must also successfully complete an entrance examination.

To paraphrase Neil Armstrong, a high-school senior should make plans now to continue his education after graduation for his own "giant leap" in electronics.

R-E



EARN YOUR FCC ticket . . . Many correspondence school grads become licensed broadcast radio and television engineers. Courtesy Cleveland Institute of Engineering

electronics program at a four-year college.

Apprenticeship programs

If you don't have time or a desire for formal training in electronics, give thought to on-the-job or apprenticeship training. Under the direction of the Department of Labor, apprenticeship programs incorporate classroom training with full-time employment. Apprentices follow a schedule of work progress and related book knowledge which leads to journeyman status in four years. Your apprentice's pay will be approximately 50% of what a journeyman gets; increases come as you add skills and knowledge. When you complete the four-year apprenticeship program, you receive a Certificate of

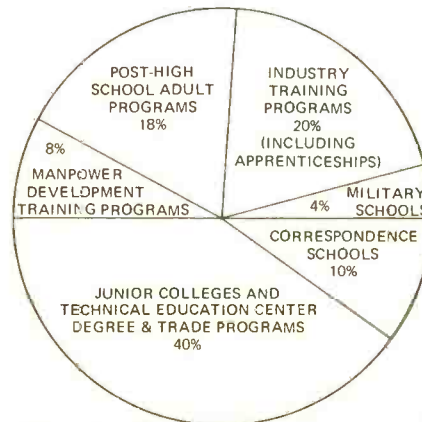

TECHNICIAN TRAINING by sources. Surely you can fit into one of these groups.

TECHNICAL TOPICS

by **ROBERT F. SCOTT**
TECHNICAL EDITOR

YOU HAVE ALWAYS SHOWN CONSIDERABLE interest in automotive electronics—particularly in the areas of safety and convenience—so when I saw the circuit in Fig. 1, I knew that I had to bring it to you.

On most cars built in the last two or three years, the parking lights are always on whenever the headlights are turned on. The safety factor in this arrangement is that if one headlight fails, an oncoming driver can immedi-

ately identify your vehicle as an automobile and determine its position on the road. Too, the oncoming driver is not likely to think that your vehicle is a motorcycle.

The circuit in Fig. 1, described by Mr. C. S. Fisher in *Electronics Australia*, shows a simple way to add this safety feature to your car. If the leads to the parking lights and headlights are available at the switch or some convenient spot under the dashboard, simply connect a diode (D1) between the lines to the parking light line and the "dip" switch as shown. If the light

lines are more accessible in the fender wells or behind the grille, then you can use two diodes (D2 and D3) between the parking lights and the high- and low-beam lines.

Note that the diodes are connected so they are forward-biased when the headlights are turned on and back-biased when the parking lights alone are turned on. The diodes must be able to handle the total current of the two parking lights.

Something for the yachtsman

When sailing to windward, the performance of a sailing dinghy or yacht is determined by the relative angle between the boat heading and the apparent wind direction. During a study of the performance of sailing vessels by the Department of Aeronautics and Astronautics at Southampton (England) University, an electronic device for indicating the apparent wind direction was developed. This device (Fig. 2), described in *Wireless World*, is simple enough to be used on even the smallest sailing craft.

The masthead unit consists of a multivibrator whose time constant is controlled by a variable capacitor rotated by a wind vane. A simple zero-center transistor voltmeter measures the variation in the mark-space ratio of the multivibrator signal and indicates it as the angle between the boat heading and wind direction over a range of 0 to 120 degrees.

The capacitor in the masthead unit is a 2-gang 500-pF variable like that found in some old trf broadcast radios. You can substitute a 3-gang 365-pF unit. The vane is formed by extending the capacitor shaft and drilling the extension for a 10-inch length of 18 gauge steel rod. One end of the rod carries a plastic vane and the other a lead counterweight.

It is essential that friction be reduced to a minimum in the capacitor rotor. This can be done by replacing the rotor wipers with flexible copper braid and by cleaning the bearings and re-lubricating with a trace of clock oil. Install a setscrew to limit shaft rotation to 110 degrees. The circuit board carrying the multivibrator is mounted on the tuning capacitor

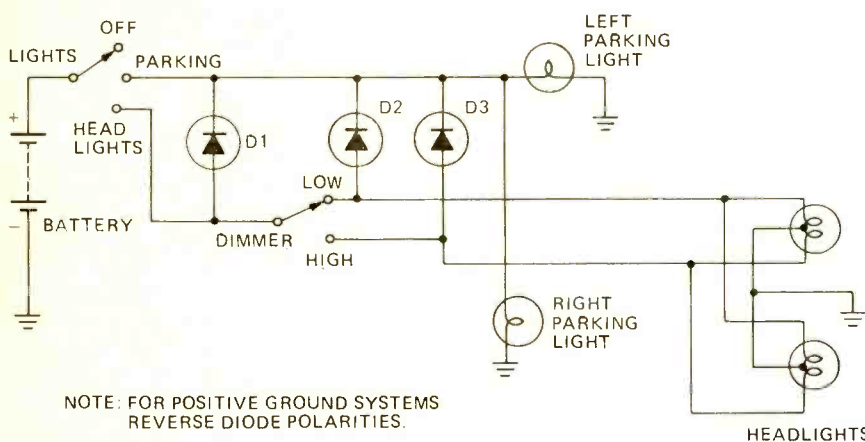

NOTE: FOR POSITIVE GROUND SYSTEMS REVERSE DIODE POLARITIES.

FIG. 1—INCREASE DRIVING SAFETY by tying parking lights to headlights as shown. With dual headlights, just connect D1 between the lines to the parking and low-beam lamps.

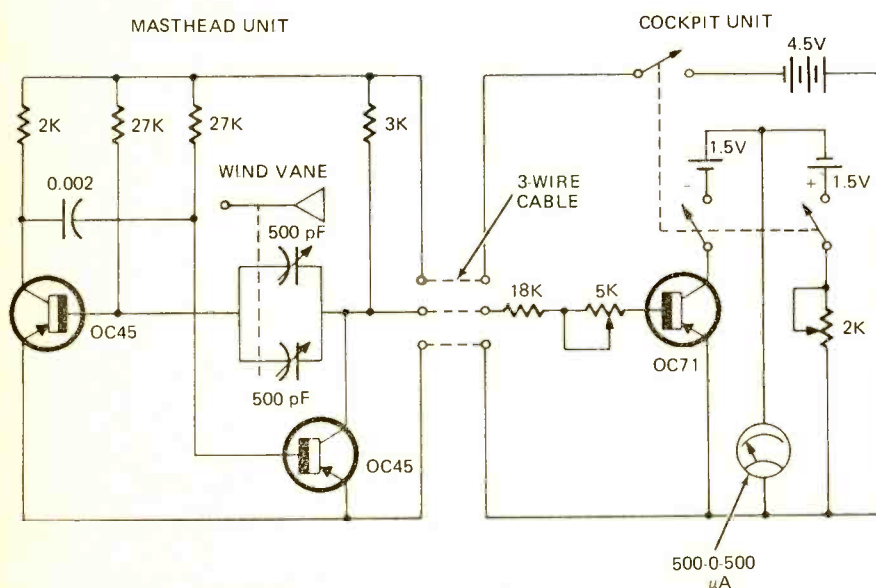

FIG. 2—SAILING DINGHYS and luxury yachts perform best at a critical angle between the heading and apparent wind direction. This circuit helps you get the most from your boat.

A selection of four practical circuits. Featured are one for your car and one for your boat. A 3-minute time delay and an audio filter are for the ham and SW listener.

and both are mounted vertically on the masthead as in Fig. 3. A 3-wire cable connects the transistor to the indicator.

To calibrate the device, open the capacitor plates 55 degrees, set the wind vane to point directly ahead of the boat and use the 2,000-ohm pot to zero the meter. Turn the vane 45 degrees on either side of the "dead ahead" position and set the 5,000-ohm pot so the meter reads plus or minus 450 μ A as appropriate. As Fig. 4 shows, a 10- μ A change is equivalent to a 1-degree change in heading or wind direction.

Time delay for transmitter control

In almost all high-power ham and

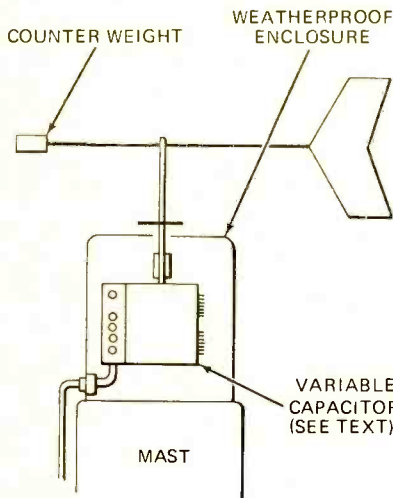

FIG. 3—WIND VANE on masthead controls mark-space ratio of a simple multivibrator.

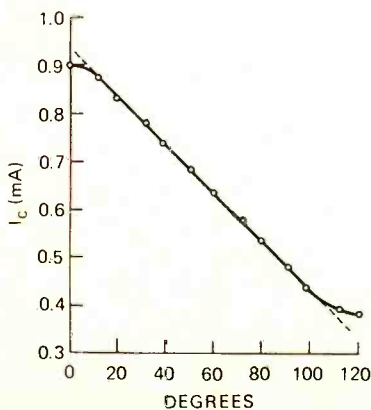

FIG. 4—CALIBRATION CURVE for the meter is linear over approximately 110 degrees.

broadcast transmitters, the tubes in the power supply and rf and af circuits should be allowed to reach full operating temperature before B-plus voltage is applied. In some equipment, a delay of up to 3 minutes should elapse between application of the filament and B-plus plate voltages.

Many broadcast transmitters are located out in the boondocks and are unattended, so some means must be provided for the necessary time delay and to provide for power interruptions. Similarly, many air conditioners, freezers and refrigerators require a minimum delay before power is reapplied following a power interruption.

Here is an electronic time-delay circuit (described by W. T. Maloney, in *Electronic Engineering*, London, England) that delays application of plate power up to 3 minutes. It reapplies power immediately upon interruptions

of up to 5 seconds and provides proportional delays for longer interruptions.

The circuit, Fig. 5 is based on a timer using a 2N2647 unijunction transistor. When the filament switch is closed, power is applied to the filaments and to the 50-volt control supply. RY2 is energized so its contact closes, connecting timing capacitor C1 to the 2N2647 emitter through the normally closed contacts of RY1. The capacitor charges through R1, R2 and D1 until it reaches a level equal to the unijunction's peak-point emitter voltage. (This is the point where the emitter-base-1 diode junction is forward biased and emitter current flows. The peak-point voltage can be considered as the unijunction's trigger level. The time required for C1 to charge to the peak-point voltage is determined by the setting of R5.)

At this point, C1 discharges

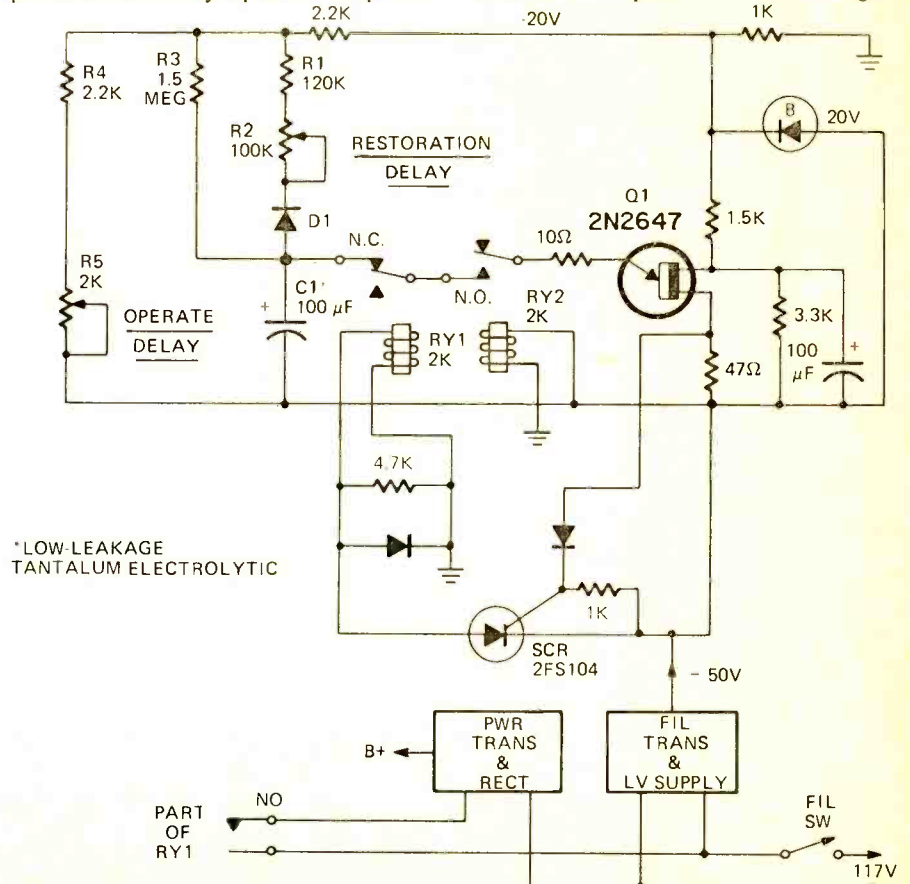

FIG. 5—TIME-DELAY CIRCUIT FOR TRANSMITTERS insures that the mercury-vapor rectifiers and high-power tubes reach operating temperature before B+ is applied.

through the emitter-base junction and develops a voltage drop across the 47-ohm base resistor. The voltage pulse across this resistor turns on the SCR and energizes RY1. The normally open (N.O.) contacts switch on the transmitter plate supply and the normally closed (N.C.) contacts break the circuit between C1 and the uni-junction emitter. Capacitor C1 now charges to the level of the 20-volt line.

If the power is interrupted, the control voltage is removed and C1 starts to discharge through D1, R1, R2, R4 and R5. Relay RY2 is de-energized and its contact opens, preventing C1 from discharging through the emitter-base diode of Q1. Filament and control voltages are applied as soon as power is restored. RY2 is energized, closing its contacts.

If power is restored within 5 seconds, C1 has not yet discharged below Q1's peak point voltage level, and Q1 fires the SCR and turns on the plate supply. If power is not restored before the charge on C1 drops below Q1's trigger level, the timer recycles and the time delay in reapplication of plate power is equal to the time required for C1 to charge to the Q1 trigger level. Potentiometer R5 is adjusted for the original time delay (3 minutes) and R2 determines the time delay after a short power interruption.

Phone and CW filter

Many inexpensive communications receivers can be improved and made more immune to interference by limiting circuit bandwidths to the

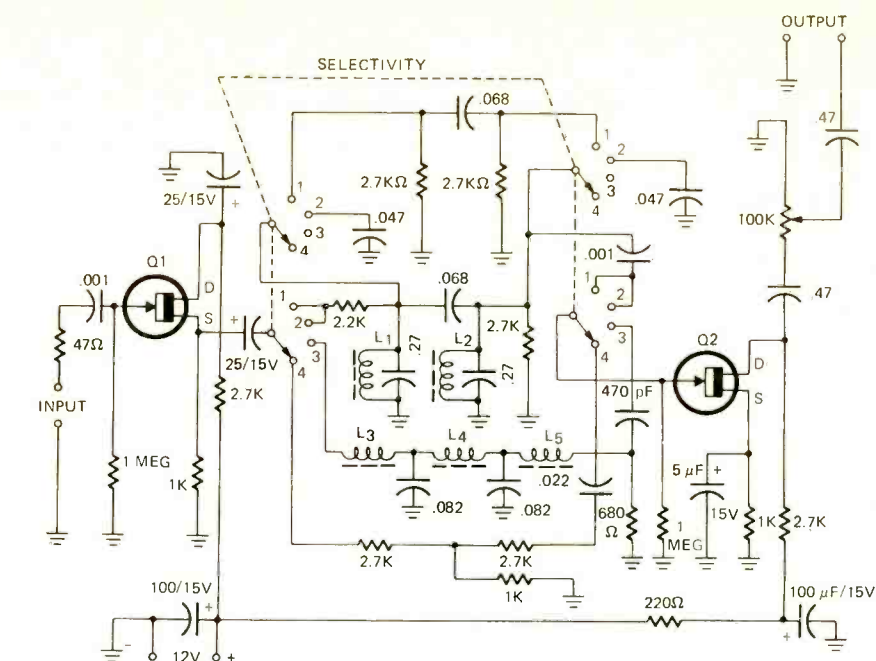

FIG. 6—SELECTIVE AUDIO FILTER for inexpensive ham-band and shortwave receivers. Its three degrees of selectivity should prove valuable in direct-conversion sets.

minimum required for the particular mode of transmission. Fig. 6, from the amateur-radio column of *Le Haut-Parleur*, shows phone/CW filters that can be added to many receivers. Positions 1 and 2, for CW, provide passbands centered on 900 Hz with bandwidths of 400 and 200 Hz, respectively. Position 3 provides a bandwidth of from 300 to 3000 hertz for AM reception. Position 4 provides normal audio response with a resistive attenuator to provide the same

amount of attenuation as the bandpass filters.

Transistors Q1 and Q2 are type EC300 FET's. Any similar N-channel FET may be used. Source-follower Q1 matches preceding high-impedance audio circuits to the filter networks while Q2 compensates for the filter attenuation. Toroids L1, L2, L3 and L5 are 88-mH units and L4 is a 124-mH toroid. These inductors are available as surplus components from several mail-order sources. **R-E**

laser communications

A new lightweight, hand-held laser communications system is now being tested by the Los Angeles police department. The instrument, demonstrated by Stabilized Optics Corp. of Cupertino, CA,

operates with an infrared laser beam and has a range of at least 12 miles under good visibility conditions. Using infrared light as a carrier, with a beamwidth of only a quarter of a degree and an aver-

age power of half a watt (25 watts peak) transmissions are virtually undetectable.

The Los Angeles police are testing the unit primarily for communication between helicopters and police cars.

The 6-pound unit has a monoscope (one-eyed telescope) for keeping the other station in the beam, a radar transmitter with a 7 kHz pulse rate, and a modulation system that transforms voice messages into a digital code that is applied to the 7-kHz pulse frequency of the laser. The receiver translates the digital signals back into voice frequencies.

The specified range is 12 miles, but the system has had no difficulty in working up to 20 miles between airplanes and ground.

Particularly useful in police work, the system could also be used for communications between ships or planes, ship-plane or plane-airport communications. As a straight digital transmitter without voice modulation, it could be used for data transmission within cities, relieving pressure on overcrowded radio bands.

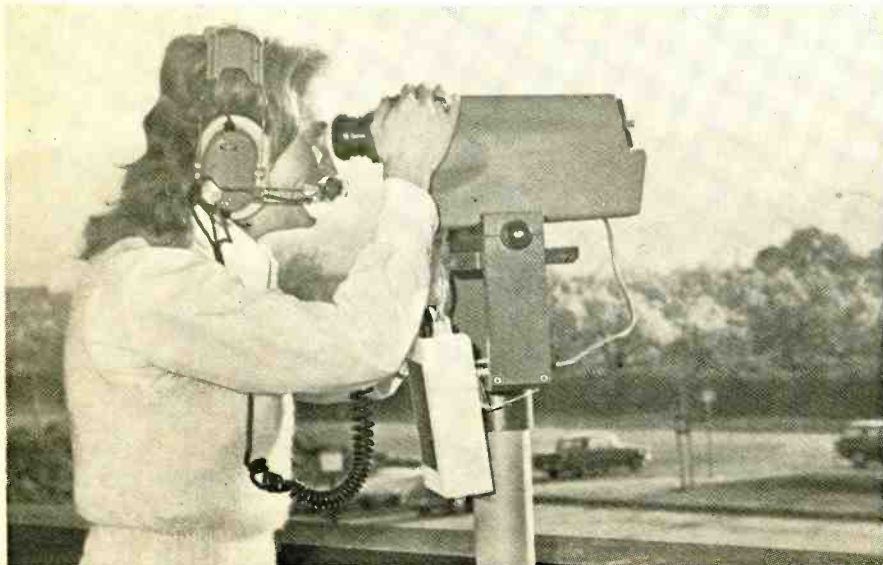

Servicing Record Changers- 21 basic steps

*Record changers can be a problem to repair.
Try the procedure spelled out in this
article and eliminate the headaches*

by ELLIOT S. KANTER

ACCORDING TO THE LATEST STATISTICS, home entertainment systems (stereo-hi-fi) represent a major portion of the average consumer's electronic investment. Stereos come in all sizes, shapes and prices from a budget-stretching portable to the most elaborate custom-installed system imaginable.

Basically, each system consists of some source or sources (tuners, tape players or record-players), an amplifier and speakers. It would be safe to say, that everyone reading this article has at least one record player or changer in his home, and frequently it needs repair or adjustment. Fortunately, the electro-mechanical record changer can

**TABLE I
BASIC TOOLS & MATERIALS**

ITEM AND ACCEPTABLE SUBSTITUTE

- 1/8-inch screwdriver
- 1/4, 3/8, 7/32-inch wrench cr Socket wrenches
- Q-Tips or cotton swabs
- Rubber Magic or denatured alcohol
- Phono-Lube (GC1223) or General purpose oiler
- Paper toweling (kitchen)
- Degreaser (spray) or Tune-O-Wash

OTHER TOOLS NOT REQUIRED BUT HANDY

- Universal changer power cord
- 4-lengths (approx 3-inch each) 1/2-inch wood dowel
- Strobe-disc
- Chain-nose pliers
- Spray cleaner, Windex, 439
- Spray wax

be serviced quite adequately if you have the proper tools and know the proper techniques.

We will examine and repair a typical record changer and completely service it to the extent of rebuilding its motor. The techniques described in the motor disassembly portion are applicable to any small motor (drill, kitchen appliance, hair dryer, etc.) and will prove a useful aid in their repair.

Before we can begin to service the record changer, we must make sure we have the proper tools. A suggested list of tools and materials are in Table I. These items represent a maximum investment of about \$15.00, depending on how many of them you already have. Very few items are critical and a multitude of substitutes and sources are listed.

Figure 1 shows a common auto-



FIG. 1—TYPICAL RECORD CHANGER. Note that there is usually only a single C-clip holding the platter in place.

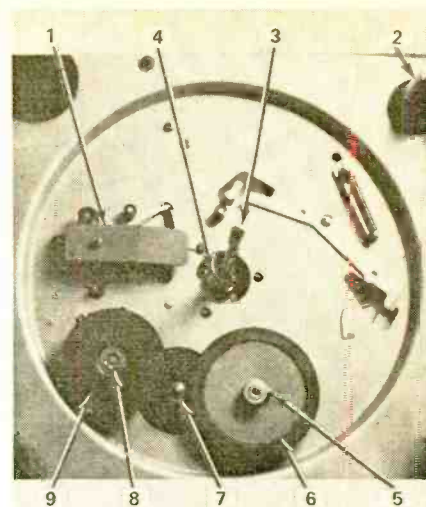

1. A.C. SWITCH
2. OVER ARM SHAFT
3. SPINDLE
4. PLATTER BEARINGS
5. DRIVE WHEEL SET SCREW
6. DRIVE WHEEL (NOT ON ALL TURNTABLES)
7. MOTOR SHAFT & PULLEY
8. IDLER WHEEL RETAINING SCREW (MIGHT ALSO BE "C" CLIP)
9. IDLER WHEEL

matic turntable used by a great many manufacturers of home stereo systems. All systems, with only one or two exceptions will have the components described in this article and can be serviced in the same manner. Before we can service the system, we must first remove the platter to get at the various mechanisms. Using a screwdriver (Fig. 1) pry loose the C clip which holds the platter in place and remove the platter by lifting straight up. If the platter fails to lift freely, spray a little degreaser to free the main shaft and permit easy removal.

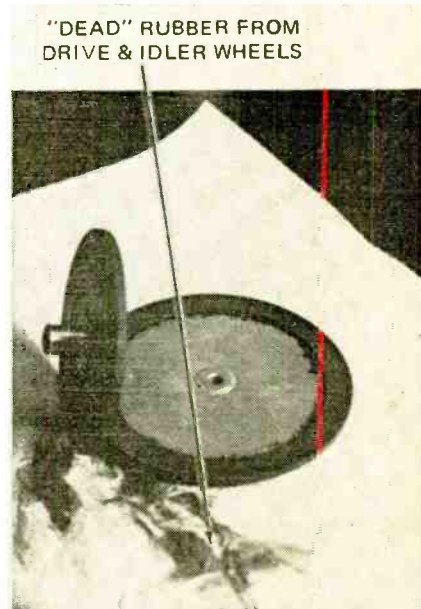

FIG. 2—DEAD RUBBER FROM DRIVE & IDLER WHEELS is a frequent troublemaker. Careful cleanup offers the best solution.

Figs. 2 and 3 are closeups of the inner mechanism of the typical record changer. Basically, most problems center around the idler wheel (Fig. 2) and the motor bearings (Figs. 6 and 7).

The idler wheel and the drive wheel (if the unit has one) are made of a rubber-type material and have a tendency to become brittle with age or develop a film which tends to cause slippage.

The motor shaft and bearings are subjected to dirt, grease build-up and a condition referred to as bearing freeze-up. This particular problem is a result of accumulated dirt, hair and grease which results in the bearings(s) becoming frozen or locked and the motor then overheats with absolutely no platter movement. In other cases, it creates a low-torque condition.

The cam-assembly identified in Fig. 5 is not usually a problem causer.

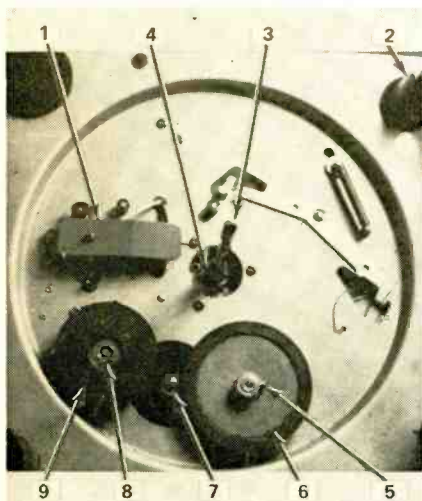

1. A.C. SWITCH
2. OVER ARM SHAFT
3. SPINDLE
4. PLATTER BEARINGS
5. DRIVE WHEEL SET SCREW
6. DRIVE WHEEL (NOT ON ALL TURNTABLES)
7. MOTOR SHAFT & PULLEY
8. IDLER WHEEL RETAINING SCREW (MIGHT ALSO BE "C" CLIP)
9. IDLER WHEEL

FIG. 3—WITH THE PLATTER OFF here's what you are likely to see. All important parts are identified.

unless the turntable has been rotated counter-clockwise. If this is the case, it is best to secure a replacement assembly as there are a number of tiny pins and levers which have been damaged beyond repair. The newer free-wheeling turntables are not subject to this kind of damage.

The actual overhaul of the record changer goes like this.

1. Remove the idler wheel and the drive wheel (if the unit has one) by loosening the screw(s) or removing the

C clips holding it in place.

2. Saturate a piece of towelling with Rubber Magic and rub the edges of both wheels to remove the dead rubber and all traces of film (Fig. 4).



FIG. 4—CLEAN IDLER AND DRIVE wheels thoroughly. Dry with a separate piece of clean towelling.

After thoroughly rubbing the edge(s), go over it again with a clean towel to remove all traces of residue.

3. Completely clean the shaft the idler wheel was mounted on and also the motor pulley. A cotton swab moistened with Rubber Magic will facilitate a thorough cleaning.

4. After the idler wheel shaft has been cleaned apply a drop of lubricant (oil or Phono-Lube) and allow it to drip down the shaft.

5. Remove the C clips (Fig. 6) holding the motor to the bottom of the record changer.

6. Scribe (scratch) a mark on the motor housing (Fig. 8) for alignment purposes.

7. Remove the motor from the base and disassemble by removing the screws.

8. Refer to Fig. 11, and liberally spray the upper motor bearing and shaft with the degreaser. Then, apply a drop of lubricant to the shaft and work it (the shaft) in and out of the top bearing. Continue adding lubri-

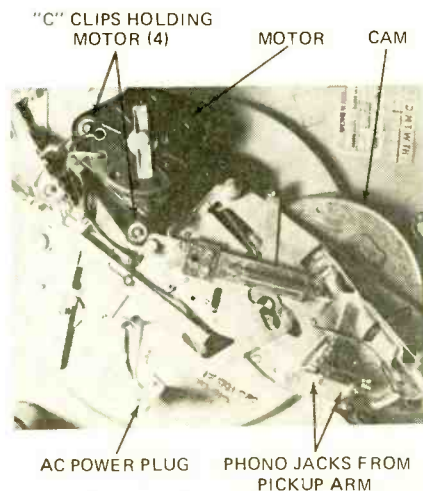

FIG. 5—CAM ASSEMBLY is usually not a problem unless turntable has been accidentally rotated backwards.

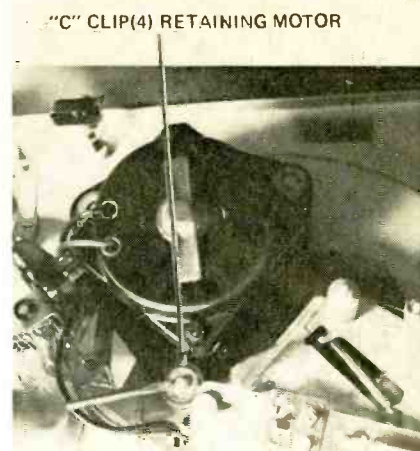

FIG. 6—C CLIPS hold the motor in place. Remove them, then the motor, to get at the upper motor bearings.

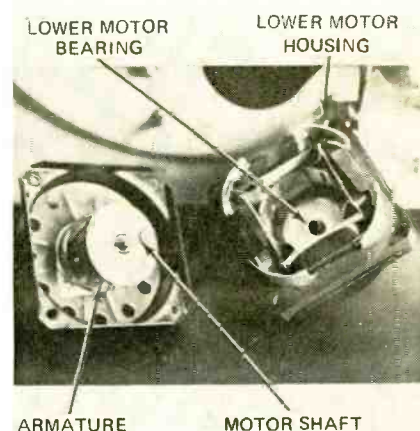

FIG. 7—CHECK THE LOWER BEARING for traces of dirt or other foreign matter. Clean with cotton swab.

cant a drop at a time until the shaft shows no trace of dirty oil deposits or grease and spins freely. At this point apply a single drop of lubricant to the top bearing and set the assembly aside.

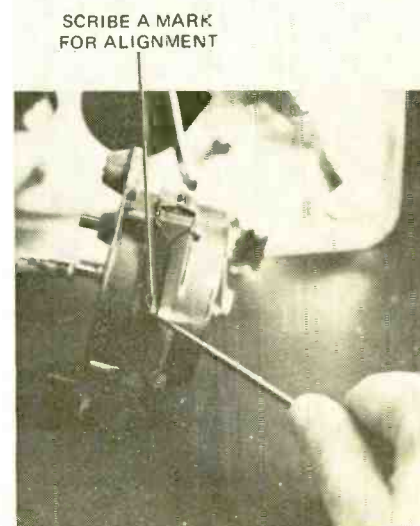
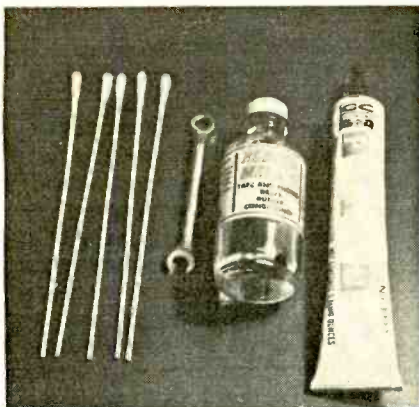

FIG. 8—SCRIBE A MARK on the motor housing to insure proper replacement positioning when you finish.

9. Examine the lower bearing (Fig. 7) for any traces of dirt or foreign matter. Spray it completely with the degreaser. Saturate a swab with oil and clean the inner surfaces of the bearing. Rotate the swab in the bearing opening while adding a drop or two of oil to clean the side surfaces.



TURNTABLE CLEAN-UP KIT consists of cotton swabs, hypodermic-type oiler, solvent, and lubricant.

10. After cleaning and freeing the lower bearing, apply a single drop of lubricant to the bearing opening and set it aside.

11. Reassemble the motor, line up the mark made in step 6. Before tightening the screws down, tap (lightly) the lower bearing housing with a screwdriver handle while spinning the shaft. This balances the motor shaft and insures that it is correctly seated in both the upper and lower bearings. Now tighten the screws completely. At this point you could utilize the 'universal' power cord to check motor operation, this is not necessary.

12. Replace the motor and secure it with the four C clips removed in step 5.

13. Using a saturated towel (Rubber-Magic), wipe the inside rim of the platter clean of rubber residue (Fig. 9).

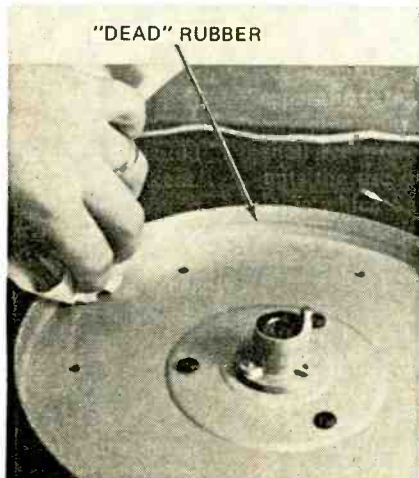

FIG. 9—WIPE THE INSIDE RIM of the platter clean of rubber residue. Use a towel saturated with solvent.

14. Refer to Fig. 3 and remove the platter bearings. Clean and lightly lubricate them and replace in *same* order removed.

15. Lightly apply a tiny amount of Phono-Lube to moving parts located on the underside of the changer. Too little lubricant is much better

than too much!

16. Carefully replace the cleaned idler wheel and the drive wheel on their respective shafts, and secure. Manually operate the speed selector and observe the relative position the idler wheel takes in respect to the motor pulley. It should be approximately

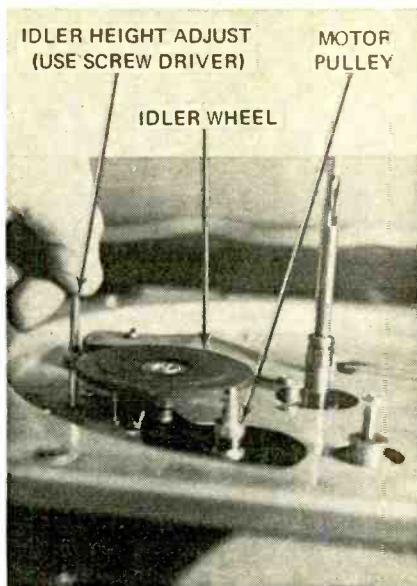

FIG. 10—IDLER WHEEL HEIGHT must be set properly to insure that the motor pulley mates properly.



FIG. 11—DEGREASE, THEN LUBE the upper motor bearing before replacing the motor on the turntable.

centered in each of the increments of the pulley (16-33-45-78). If it is not centered use the idler wheel height adjustment (Fig. 10) to raise or lower the wheel as required.

17. Replace the platter with a slight spinning (clockwise) motion to seat the platter and position the idler wheel as required.
(continued on page 71)

TABLE II—TROUBLESHOOTING CHART

SYMPTOM	CAUSE & CURE
Audio:	
1. Buzz in output one or both channels	Poor ground connection to cartridge, turntable, bad connection to cartridge, check and correct.
2. One channel dead, phono only	Shielded cable open, or bad wire in pickup arm, test cable by substitution, repair or replace.
3. Muddy sound, distortion	Glob of dust/dirt on stylus, or worn stylus; remove dirt or replace stylus.
4. Intermittent sound, low output	Test cartridge by lightly applying pressure to pickup arm while playing <i>OLD</i> record, if pressure corrects problem, replace cartridge.
Mechanical:	
1. Arm slides across record	Bad stylus, replace.
2. Arm sets down too soon/late	Readjust set-down, adjustment screw located in rear of pickup arm assembly, turn as required.
3. Won't auto-cycle	Check overarm, must be free, clean and oil, if bent, straighten, check, clean idler wheel.
4. Arm sets down in middle of record	Check to see size is set for 12-inch, or speed for 33 $\frac{1}{3}$ rpm.
5. Won't turn	Motor frozen, clean, free bearings, oil as described in text.
6. Slows in cycle or erratic speed	Clean and reface idler wheel, oil upper motor bearings (1-2 drops) check idler wheel height.
7. Won't cycle 45's	Check speed, idler wheel height, replace 45 adapter.

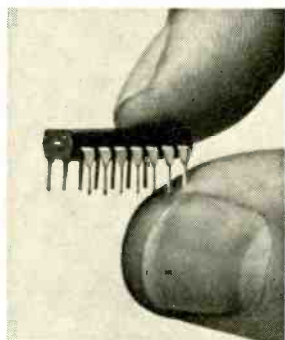

4,000 functions in a single LSI circuit. The functions of four thousand separate transistors, represented by the dots above, can now be performed by the LSI circuit shown in the photo.

LSI...will it make or break your job future?

The development of LSI (large scale integration) technology in the 1970's is the dawn of the newest revolution in Electronics. It means that many of today's job skills soon will be obsolete. But at the same time, it opens the door to thousands of exciting new job opportunities for technicians solidly grounded in electronics fundamentals. Read here what you need to know to cash in on the Science of the Seventies and how you can learn it right at home.

LSI circuits, some no bigger than a bumblebee, are bringing about a fantastic new Industrial Revolution. Already these miracles of micro-circuit technology are a part of exotic equipment that saves lives, works complicated mathematical formulas in an instant, or tells time within a tolerance of two seconds per year.

LSI's may also put you into a whole new and more rewarding career . . . or put you out of a job!

In the fall of 1972, BUSINESS WEEK reported, "Because of its fast pace of innovation, the U. S. semicon-

ductor industry leads the world. In the LSI market, U. S. domination is even more pronounced."

A single LSI circuit now can perform the function of more than 4,000 components and scientists predict that the use of electron beams to trace the circuit patterns will soon make it possible to put 10,000 transistors and similar devices on a silicon chip a few millimeters square.

Miniature Miracles of Today and Tomorrow

Already, as a result, a two-way radio can now be fitted inside a signet ring. A complete hearing aid can be worn entirely inside the ear. There is a new computer/calculator that weighs only nine ounces, fits easily into a shirt pocket, yet in a split second performs logarithmic, trigonometric and mathematical functions with a single keystroke and 10-digit accuracy. And new, extremely accurate watches consisting only of a quartz crystal, LSI circuits and a solid-state time display take only minutes to assemble.

And this is only the beginning.

Soon kitchen computers may keep the housewife's

The arithmetic of the computer and its relative, the calculator, is performed by combinations of logic circuits. Graphic symbols for logic elements simplify schematics and make understanding and troubleshooting easy.

by H. EDWARD ROBERTS*

Logic circuits

Three basic types of gating circuits can be used to implement almost any logic requirement. They are AND gates, OR gates, and NOT circuits. An example of a typical complex logic requirement is a BCD to 7-segment decoder. This logic circuit converts the BCD code for a decimal number into the correct drive signals for a 7-segment display. Over 70 gates are required to do this conversion. Fortunately for the logic designer, 7-segment decoders are available as single integrated circuits from many semiconductor manufacturers. There are many other cases where single IC's are available for complex logic operations, but there are also many where the logic designer must build up circuits with individual gates.

Before describing the various types of logic circuits in more detail, a few words on symbology are in order. Until very recently, literally dozens of logic symbol systems were in use. Fortunately a standard set of symbols has been developed and is known as MIL-SPEC 801B. These standard symbols are now used by most semiconductor manufacturers, and they are used in this article.

AND gates

The AND gate is a circuit which requires a 1 signal on all of its inputs to give a 1 signal at the output. Any other condition will produce a 0 on the output. Normally 1 is represented by a high voltage state while 0 is represented by a low or zero voltage. Fig. 1 shows the standard logic symbol for

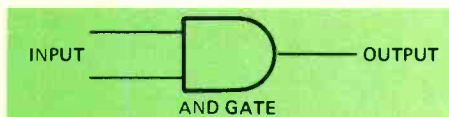

FIG. 1—GRAPHIC SYMBOL for the AND gate—one of the basic logic elements.

an AND gate.

OR gates

The OR gate will produce a 1 on its output when a 1 appears on any of its inputs. If there is no 1 at the input, the output will always be 0. The standard logic symbol for an OR gate is

shown in Fig. 2.

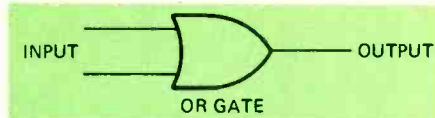

FIG. 2—OR-GATE SYMBOL is concave on the input side and pointed on the output side.

NOT circuits

A NOT circuit is simply an inverter that complements the input signal. Since there are only two binary states, it follows that a NOT 1 is a 0 and vice versa. The NOT circuit is represented as a triangle.

NAND and NOR gates

In practice the most common logic circuits are NAND and NOR gates. These circuits are simply AND and OR gates followed by an inverter (NOT circuit) on the output. The symbols for NAND and NOR gates are shown in Fig. 3. Note the symbol for the NOT circuit which follows two of the symbols.

The operating rule for a NAND gate is that a 1 on both inputs will produce a 0 on the output. The operating rule for a NOR gate is that a 1 on either input will produce a 0 on

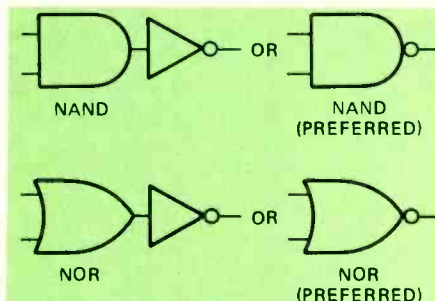

FIG. 3—GRAPHIC DIAGRAMS of logic circuits are simplified by preferred symbols.

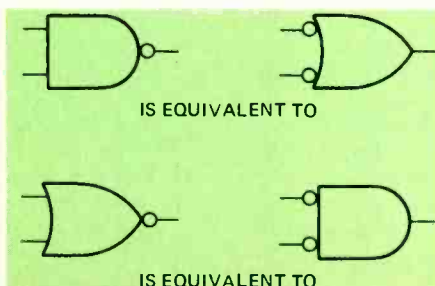

FIG. 4—THE SMALL CIRCLE on the lead shows inversion occurs at the circuit output.

the output. Note that the preferred symbol for both gates as shown in Fig. 3 condenses the triangle NOT gate into a small circle at the output. This same shorthand technique can be used where the input requires a 0 to activate the output. Fig. 4 demonstrates this important concept in logic design and analysis with the appropriate symbols. The reader should verify that the circuits are really equivalent by tracing various input conditions through each.

Binary adder circuit

Now that the basic logic circuits and functions have been explained, let's connect several together to form a practical system. Fig. 5 shows how

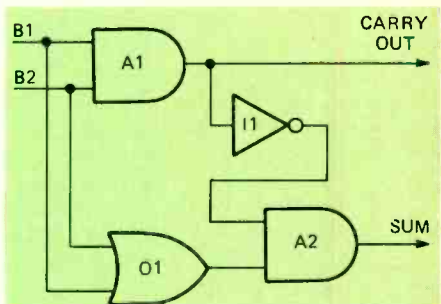

FIG. 5—A TWO-BIT BINARY ADDER is formed from 2 AND's, 1 OR gate and inverter.

several gates can be connected to form a two-bit binary adder. To illustrate how this adder operates, assume that input bit B₁ is a 0 and bit B₂ is a 1. A 0 and 1 into A₁ produces a 0 on the output, and this indicates there is not a carry in the answer. The output of O₁ is a 1 and the inverter I₁ also has a 1 output. The two 1's into A₂ results in a 1, the correct sum of 1 and 0, on the output of A₂. To verify operation of the adder, try other combinations and see if they result in correct answers.

Flip-flops

Three classes of flip-flops are commonly used in computing circuits: bistable multivibrators, monostable multivibrators, and astable multivibrators. All flip-flops have two outputs, and these outputs are always complements of one another. For example, if one output is a 0, the other

will be a 1 and vice versa.

1. Bistable Multivibrators have many forms, but all are characterized by their ability to maintain an output condition until this state is changed by a new input. This type of flip-flop is by far the most common in digital circuitry. They are used to store data in memories and shift registers, count, act as frequency dividers, remember status of logic circuits, and in other operations. The most common bistable flip-flops are the J-K, the R-S, T, and D. It is beyond the scope of this article to discuss each flip-flop individually, but knowing each changes its output state only when directed to do so by the input permits an understanding of any particular type. All that is required is to study the input logic table for each flip-flop in question. This information is provided by the manufacturer in the device's specification sheet.

2. Monostable Multivibrators (monostable flip-flop) has only one stable state and always returns to this state a predetermined time after being activated. The time period is usually determined by an R-C time constant. Monostables are used primarily for synchronization and timing, and the number of them in a particular logic circuit is generally quite small in relation to the number of bistable circuits. In fact, many experienced designers judge the merits of a logic design by the number of monostable flip-flops it incorporates (the more used, the poorer and less efficient the design).

3. Astable Flip-Flops, also known as free-running multivibrators, have no stable state. Instead, they oscillate with a period usually determined by an R-C time constant. This type of circuit is commonly used as the basic timing generator or clock in most calculators. The frequency stability of astable circuits is limited to about $\pm 20\%$ in most production designs, and these relatively large errors prevent its use in precision timing circuits.

Typical flip-flop applications

Typical flip-flop applications include counting and frequency division, operations which can be performed by

a typical type "T" flip-flop. The type "T" flip-flop shown in Fig. 6 has the

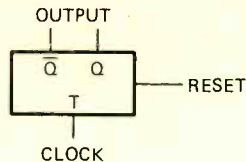

FIG. 6—TYPE "T" FLIP-FLOP's output changes state when input switches from 1 to 0.

characteristic that whenever the input signal at T changes from a 1 to 0 state, the output of the flip-flop will change. In the figure, the bar over output \bar{Q} is read "not Q", meaning it is inverted from the Q output. The input labeled RESET will clear the flip-flop by setting the \bar{Q} output to 1 and the Q output to 0.

To see how a circuit containing only three type T flip-flops can be used for counting and frequency division, see Fig. 7. Fig. 8 is a timing diagram which shows the relationship of the flip-flop outputs (Q) to one another and the input signal.

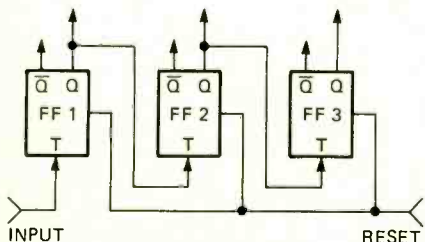

FIG. 7—DIVIDING BY EIGHT is easy. Use three "T" flip-flops connected as shown.

Before the flip-flops are activated, a reset pulse is applied to set all the flip-flops in the counter to zero. At t_0 the input signal changes from a 1 to a 0 and this causes FF1 to change from a 0 to a 1. Even though this output is fed to FF2, no change occurs on FF2 since a change can only be initiated by a 1 to 0 transition. After a time interval determined by the clock, the input signal changes from a 0 to a 1 again and there is no change in any flip-flop.

When the unit starts into the second cycle (changes from a 1 to 0) the input signal activates FF1 causing it to change from a 1 to a 0. This transition

causes FF2 to change from a 0 to a 1, again with no effect on FF3. To see how the input signal pulses effect the various flip-flops and the resulting outputs, refer to Fig. 8 and trace the input signal through the remainder of the cycles shown.

The timing diagram in Fig. 8

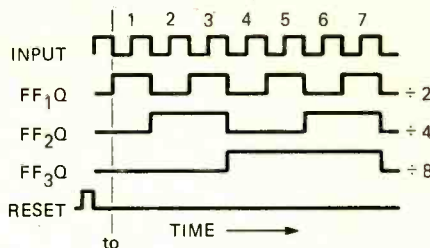

FIG. 8—TIMING DIAGRAM shows the instantaneous relationship of Input to the outputs.

shows that the output frequency of FF1 is only half the input frequency. Similarly, the outputs of FF2 and FF3 are a fourth and an eighth of the input frequency respectively. This clearly demonstrates the frequency divider characteristic of the bistable flip-flop.

In addition to frequency division, the flip-flop chain shown in Fig. 7 is extremely useful as a counter. For example, consider the outputs of all three flip-flops after three input cycles:

FF3 FF2 FF1
0 1 1

011 is the binary equivalent of the decimal 3, the number of input cycles which have occurred. This shows that the flip-flops have counted the number of incoming pulses and have recorded the number by placing the least significant digit in FF1 and the most significant in FF3. The counting operation can be verified by checking the output states during the sixth cycle (see Fig. 8):

FF3 FF2 FF1
1 1 0 = 6_{10}

This concludes our discussion of electronic arithmetic and logic. The next article in this series will describe memories for electronic calculators, and then we will be ready to discuss the organization of the various subsystems in an actual, working calculator. **R-E**

VERTICAL BUZZ, G-E SF CHASSIS

The buzz comes from laminations in the vertical output transformer. Heat from resistor R404 can soften the transformer wax. This allows the laminations to vibrate, causing the buzz.

To remedy the problem, remove R404 from its bracket. Remove one screw and disassemble the bracket from the transformer and electrolytic capacitor. Bend bracket 90 degrees as shown in the drawing. Reassemble the bracket and R404. Allow the transformer to cool about one hour before applying power. This will allow the wax to harden.

Caution: In SF1600 series receivers, slide R404 down in the clip so there is at least $\frac{1}{2}$ inch between R404 and the

bottom cover of the vhf tuner. In SF2200 series receivers, maintain at least 1 inch space between R404 and the antenna terminal assembly.—*G-E Television Service Bulletin*

MAGNAVOX SPEAKERS—FUSIBLE RESISTORS

Speaker systems such as the models 1S8757 through 1S8759 and 1S8762 through 1S8766 have a fusible resistor in series with the positive lead to the speakers. It protects against excessive current flow in the event of a shorted speaker voice coil. This fusible resistor is rated 0.225 ohm, 2 watts and is part No. 240104-3.

Because of the protective characteristics of this device, use only the exact replacement.—*Magnavox News Letter*

refrigerator stocked, her menus planned, and her calories counted. Her vacuum cleaner may creep out at night and vacuum the floor all by itself.

Money may become obsolete. Instead you will simply carry an electronic charge account card. Your employer will credit your account after each week's work and merchants will charge each of your purchases against it.

When your telephone rings and nobody's home, your call will automatically be switched to the phone where you can be reached.

Doctors will be able to examine you internally by watching a TV screen while a pill-size camera passes through your digestive tract.

New Opportunities for Trained Men

What does all this mean to someone working in Electronics who never went beyond high school? It could mean the opportunity of a lifetime — if you take advantage of it.

It's true that the "LSI" may make a lot of manual skills no longer necessary.

But at the same time the booming sale of articles and equipment using integrated circuitry has created a tremendous demand for trained electronics personnel to help design, manufacture, test, operate and service all these marvels.

There simply won't be enough college-trained engineers to go around. So men with high school educations who have mastered the fundamentals of electronics theory may soon fill really interesting, high-pay jobs as engineering aides, technicians and service specialists.

How To Get the Training You Need

You can get the up-to-date training in electronics fundamentals you need and do it at home in your spare time without giving up your present job or income. Cleveland Institute of Electronics courses are specially designed for home study and feature AUTO-PROGRAMMED® Lessons. Even if you have no experience in Electronics or had trouble studying before, CIE courses help you advance faster and easier than you would have believed possible. You learn at your own pace.

Unlike a classroom situation where you have just one instructor throughout the course, at CIE you get help from a number of instructors. Each is selected on the basis of his specialized knowledge of a particular area of Electronics. In this way, you benefit from the combined knowledge of our entire staff.

Money-Back FCC License Warranty

A Government FCC License is certification of your knowledge of Electronics. Some jobs, especially in broadcasting, require a license, but nearly every employer recognizes its value. So why doesn't everyone who wants a good job in Electronics get an FCC License?

The answer: it's not that simple. You must pass a Government licensing exam. A good way to prepare for

your FCC exam is to take a licensing course from Cleveland Institute of Electronics. Our training is so effective that in a recent survey of 787 CIE graduates, better than 9 out of 10 CIE grads passed the Government FCC License exam.

That's why we can offer this famous Money-Back Warranty: when you complete any CIE licensing course, you'll be able to pass your FCC exam or be entitled to a full refund of all tuition paid. This warranty is valid during the completion time allowed for your course. You get your FCC License — or your money back!

Praised by Successful Graduates

CIE training has been a big boost towards success for many men. Says Joseph Zauhar, Duluth, Minnesota, "I had three good job offers after I finished my CIE training and accepted a position as Technical Editor for Electronic/Technician Dealer Magazine. I've since been promoted to Managing Editor." From Cambridge, Massachusetts, Joe Perry reports, "I'm now an Engineering Specialist with National Radio Company, Inc., testing prototype equipment. CIE training gave me the electronics technology I needed to pass the exam for First Class FCC License. I'm already earning more than I could have without my CIE training."

Approved Under G.I. Bill

All CIE career courses are approved for educational benefits under the G.I. Bill. If you are a Veteran or are in service now, check box on reply card or coupon for G.I. Bill information.

Mail Card for Two Free Books

Want to know more? Mail the postpaid reply card for two free books about opportunities in Electronics. For your convenience we will try to have a representative call. If reply card is missing, use coupon or write to:

Cleveland Institute of Electronics, Inc.,
1776 East 17th Street,
Cleveland, Ohio 44114.



MAIL COUPON TODAY:

CIE Cleveland Institute of Electronics, Inc.
1776 East 17th Street, Cleveland, Ohio 44114
Accredited Member National Home Study Council

Please send me your two FREE books:

1. Your school catalog, "Succeed in Electronics."
2. Your book on "How To Get A Commercial FCC License."

Name _____
(please print)

Address _____

City _____ State _____ Zip _____

Veterans and Servicemen:
 Check here for G.I. Bill information.

RE-24

Circle 13 on reader service card

Understanding

COMPUTER

Arithmetic

THE LARGE SCALE AVAILABILITY OF economical electronic calculators has stimulated a revived interest in electronic arithmetic. Sure, everyone knows electronic computers and calculators use a binary number system, but how does the binary system change a series of keyboard entries into a solution? In this article, the latest in a continuing series on electronic calculators, the binary system will be thoroughly explained, and some fundamental binary counting circuits will be described.

The first computing systems were mechanical and used familiar number systems to perform calculations. The abacus and more complex mechanical calculating machines operate with the decimal system since their mechanical nature makes it possible to form the ten digits required for the decimal system. The abacus, for example, signifies decimal numbers by bead placement, while more sophisticated mechanical calculating machines do the same thing using gears that have an appropriate number of teeth.

The use of binary or two-digit number schemes for control and arithmetic operations is not new. The early player piano is an excellent example of how a simple on/off code (absence or presence of a hole in a paper scroll) can be used to control a relatively complex instrument. The simplest type of electronic circuit that gives a two-position code is the on-off switch. The logic functions of the basic mechanical on-off switch can be automated by using conducting or nonconducting transistors, relays, SCR's, FET's, and other bistable components.

While the binary system is basically simple, most people find it awkward at first since they have been conditioned to count with the traditional base 10 or decimal system. To design and use binary logic, it is important to understand the binary numbering system. Fortunately the system is relatively easy to understand if a few basic rules are remembered.

In any number system, the position of a digit determines its signifi-

cance as well as the digit value. Consider, for example, the number 732:

$$\begin{array}{r} 732 = 7 \times 10^2 = 700 \\ \quad 3 \times 10^1 = 30 \quad \text{add} \\ \quad 2 \times 10^0 = 2 \\ \hline 732 \end{array}$$

This breakdown of a number shows that the position of each digit determines which power of ten the digit is to be multiplied by. For readers a little rusty in math, any number raised to the 0 power equals 1 ($10^0 = 1$; $2^0 = 1$; etc.). Also, any number raised to the 1 power equals itself ($10^1 = 10$; $2^1 = 2$; etc.). The binary system has the same position characteristics as the decimal system, except that the multiplier is a power of 2 instead of 10. Also, the binary system allows only two digits: 0 and 1.

The following example shows the composition of a typical binary number:

$$\begin{array}{r} 1001_2 = 1 \times 2^3 = 8 \\ \quad 0 \times 2^2 = 0 \\ \quad 0 \times 2^1 = 0 \\ \quad 1 \times 2^0 = 1 \\ \hline 9_{10} \end{array} \quad \text{add}$$

Note: Subscript ₂ denotes binary system while subscript ₁₀ denotes decimal system.

You can test your understanding of binary numbers by performing the above operation for several binary numbers. In addition to improving one's understanding of binary arithmetic, the technique is handy for converting binary to decimal notation.

The following table has the binary numbers for 0 through 9 already worked out:

Decimal (Base 10)	Binary (Base 2)
0	0000
1	0001
2	0010
3	0011
4	0100
5	0101
6	0110
7	0111

8	1000
9	1001

The four-digit binary numbers shown in the table are important in calculator operation. They are called binary coded decimal or BCD for short. The significance of BCD is that all ten decimal digits can be represented by a four-digit binary code.

Now that binary numbering has been explained, let's get into arithmetic. Binary addition is performed in a similar manner to decimal addition. The only difference is that a carry occurs if the sum of two binary digits is greater than 1. The following examples demonstrate this principle:

$$\begin{array}{r} \text{(a)} \quad 1 \\ + \quad 1 \\ \hline 10_2 = 2_{10} \end{array} \quad \begin{array}{r} \text{(b)} \quad 10 \\ + \quad 10 \\ \hline 101_2 = 7_{10} \end{array}$$

$$\begin{array}{r} \text{(c)} \quad 11 \\ + \quad 11 \\ \hline 110_2 = 6_{10} \end{array} \quad \begin{array}{r} \text{(d)} \quad 1011 \\ + \quad 1011 \\ \hline 11001_2 = 24_{10} \end{array}$$

To gain a better understanding of binary addition, try several other examples and check the results by converting to the decimal system and adding.

Binary subtraction uses similar techniques, and in most computing circuits subtraction is performed by complementary addition. Multiplication is normally performed by repetitive addition, and division by repetitive subtraction. The result of these operations is highly significant since all four basic arithmetic operations can be performed with a binary adder circuit.

Binary calculations may seem slow when done by hand, and repetitive addition and subtraction to multiply and divide may seem inefficient. But electronic counting circuits are so fast that binary operations are performed quite rapidly. For example, a typical calculator, such as the MITS 1440, can add two 56-digit binary numbers in less than a millisecond and can multiply the same numbers in approximately 180 ms. The MITS 7400 scientific calculator is even faster and can add two 76-bit binary numbers in approximately 120 ms.

*President, Micro Instrumentation and Telemetry Systems, Inc. (MITS)

equipment report

Lafayette LR-4000 4-channel receiver

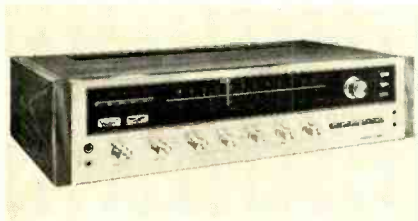

Circle 92 on reader service card

THOUGH LAFAYETTE RADIO ELECTRONICS chooses to term their LR-4000 quadrisound receiver an "SQ Receiver," in actual fact the LR-4000 is an *all-modes* 4-channel receiver, instantly ready to accommodate any present or future 4-channel signal source.

The basic package consists of an AM/FM stereo tuner, four identical pre/power amplifiers for stereo front and stereo rear, complete duplicate controls for each stereo pair, virtually every imaginable input and output connection, and of course, their full logic (with wavematching) decoder which provides three types of decoding: 1) Composer A, which is derived ambient (synthesizer) from stereo records; 2) Composer B, supposedly another type of stereo program ambient sound decode, but really a basic SQ decoder; 3) SQ, a full logic SQ decoder. Any program signal passing through the front amplifiers can be processed through the decoders. Also, any front signal can be fed front-rear stereo—appearing as stereo in both the front and rear speakers.

Front stereo inputs are provided for ceramic and magnetic phono and tape. Discrete 4-channel inputs are provided for aux 1, aux 2 and tape. Two tape recorder outputs are provided, one from the front inputs before the SQ decoder and one for discrete 4-channel, which is after the SQ decoder.

Amplifier power outputs are provided for main and remote front and rear speakers and front and rear phones. Individual on-off switches are provided for the main and remote speakers. Additional signal features include an FM detector output (should the FCC approve discrete 4-channel broadcasts), front panel stereo microphone inputs and a stereo tape output.

The sound distribution is determined by a single, uncluttered function switch; six positions give the user 2CH (stereo through front and rear speakers), Composer A, Composer B, SQ, discrete and reverse.

The receiver section features an AM/FM stereo tuner with a center channel FM and AM/FM signal strength meters, and a stereo beacon. Push switches are used for input selection, main and remote speakers, 4-channel tape monitor, 2-channel tape monitor, stereo-mono mode selection, high filter, loudness compensation and an FM mute. Concentric front/rear controls are used for volume, balance, bass, midrange and treble.

Just as there's no compromise in input/output connections, so too is there no compromise in the LR-4000's performance, especially the sound quality which was notably clean with unusually low distortion.

The measured performance of the LR-4000 (not manufacturer's specs) was an FM sensitivity of 1.6 μV IHF with 55 dB of quieting at 5 μV . Full limiting was obtained with 8 μV . At the standard test signal input of 1000 μV the frequency response measured +0.2/-2 dB from 20 to 15,000 Hz at a distortion of 0.4% THD; S/N ratio was 72 dB. The stereo separation measured 32 dB at 1000 Hz. The selectivity proved excellent, bringing in those closely spaced stations normally heard only on high-performance receivers.

From each stereo amplifier pair (front and rear) the power output *per channel* was 26.6 rms watts into 8 ohms at all frequencies from 20 to 20,000 Hz, at a distortion no higher than 0.08% THD at any frequency—shown in the latest accepted amplifier specifications as 26.6 rmsW/8 ohms/0.08% THD/20-20,000 Hz.

The frequency response at 26.6 rmsW/8 ohms/20-20,000 Hz was +0.2/-1.8 dB. The magnetic input was essentially *dead quiet* with a 72 dB S/N ratio.

The full logic decoder worked very well, and is the difference between hearing a "pleasant something" as matrix 4-channel or an almost spectacular surround-sound. On most program material the full logic SQ decoder would seem to *lock* onto the primary sound direction and expand

its depth, almost approximating a discrete 4-channel effect. On rare musical arrangements a slight degree of *pumping* could be heard as the logic or wavematching expanded the volume in a particular direction. But in the majority of cases the full logic SQ decoder produced an almost natural, and almost discrete effect, along with a very high degree of center-front to center-back separation (measured as 18 dB).

Part of the reason a receiver of this capability and high-performance comes with a relatively low price tag of \$499.95 lies in the full logic SQ decoder. Unlike many other partial-logic or even basic SQ decoders which utilize discrete components—several handfulls of components, the LR-4000 has a substantial part of the necessary decoder circuits in an IC, which represents a considerable savings in components and assembly.

One thing's for certain, the user will never suffer from obsolescence for the LR-4000 has sufficient inputs and switching capacity to accommodate adaptors for CD-4 discrete, Brand X matrix decoders, 4-channel tape and just about anything else someone can dream up for a "new dimension" to quadriphonic sound.

Model A Transistor Curve Tracer



Circle 93 on reader service card

THE JUD WILLIAMS MODEL A DYNAMIC Transistor Curve Tracer is the latest version of what its maker claims is the first service-type transistor curve tracer. This versatile instrument will check practically all kinds of semiconductors; bipolar and FET transistors, UJT's, SCR's, Zener, detector and power diodes, switching diodes, and you name it. It will do this either in or out of circuit. All you need is the

(continued on page 99)

Step-By-Step TV Troubleshooter's Guide

Foreign-brand TV agc subsystems can be tough to repair if you don't try to understand them. Learn why

by STAN PRENTISS

REALLY, NO AGC SUBSYSTEM IS easy. By one method or another, it's an ac-to-dc closed loop converter whose input is dependent on its output and vice versa. Some 25 years ago manufacturers used to simply rectify part of the video i.f. signal, filter it carefully and return the resulting dc as negative bias for the tube r.f. and initial i.f. stages . . . a procedure that was all right as long there was little external noise and carrier level fluctuations weren't rapid (slow airplanes).

With increasing electromagnetic disturbances, however, keyed agc was introduced to overcome the slowness of "brute force" agc and make it additionally effective in fringe areas where signal-to-noise ratios are lower. Now, means have been found to increase the speed of what is currently known as "peak" detection and rapidly deal with any noise problems, so that once again there are keyed and non-keyed agc subsystems.

Sony is an excellent example. Fig.

1 shows Sony's i.f. strip, automatic noise canceller (ANC), and five stages of agc amplification and detection. Composite video from the emitter of 1st video amplifier Q207 appears at the junction of diode D204 and R223 where D204 and C233-R224 peak detect sync pulses only and pass them at very low level in ac coupling to the base of the Q208 automatic noise canceller. At 200-mV p-p, these sync pulses are not large enough to overcome the 0.6 V_{BE} (base-to-emitter) drop of Q208, and therefore this transistor remains cut off. But with noise spikes substantially exceeding sync amplitudes, Q208 switches on and pulls the base of Q209 to ground, cutting off all agc (and sync) for the usual microsecond or so noise duration, a period not normally recognized by the unsuspecting eye.

Without noise, Q209 and Q210 are simply a pair of amplifiers for composite video, with output from the emitter of Q210 going on to the sync separator through R232 and C236 and also through R233 to D202. Even

though D202 appears to be back biased by having 13.2Vdc on its cathode and 12.7Vdc on its anode. It is not because negative-going video is biasing this diode on. This charges C237 to an average dc value commensurate to the amplitude of the incoming sync tips . . . a process Sony terms "peak" detection. Divider resistors R235, R236 and variable VR203 now put a 13.3V forward bias on the emitter of Q204. The collector of this transistor then develops an average of 5.3V as forward bias for the base of Q202 and, through its emitter (with a 0.7V drop), across R206 and R203 to the base of Q201. Note that the Q204's collector is heavily filtered by series capacitors C238, C265 and resistors R238 and R237. Note also the agc at Q202's emitter returns to the base of Q201. It prevents agc from directly loading the first video i.f.

With agc sensitive transistors responding to forward (positive) bias, ac voltage drops as dc current increases beyond linear transistor design levels. As a result the dc voltage across

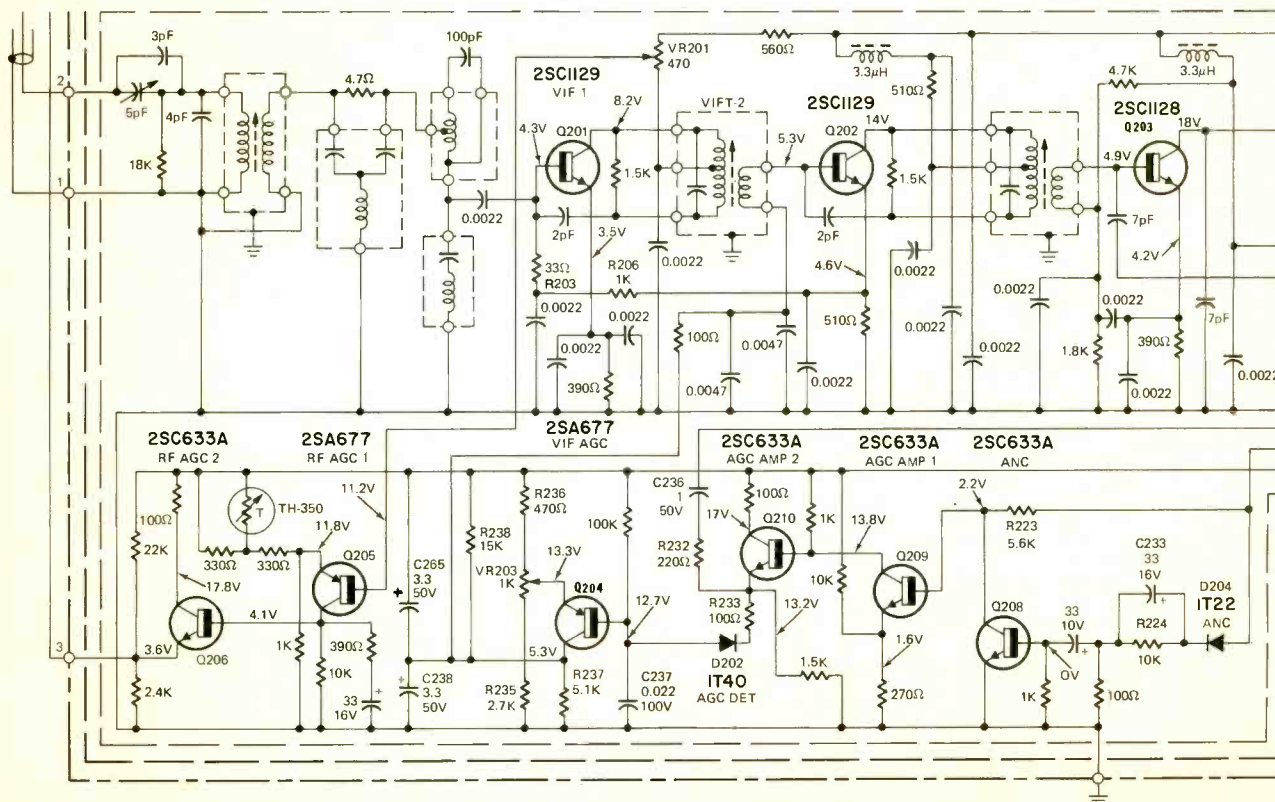

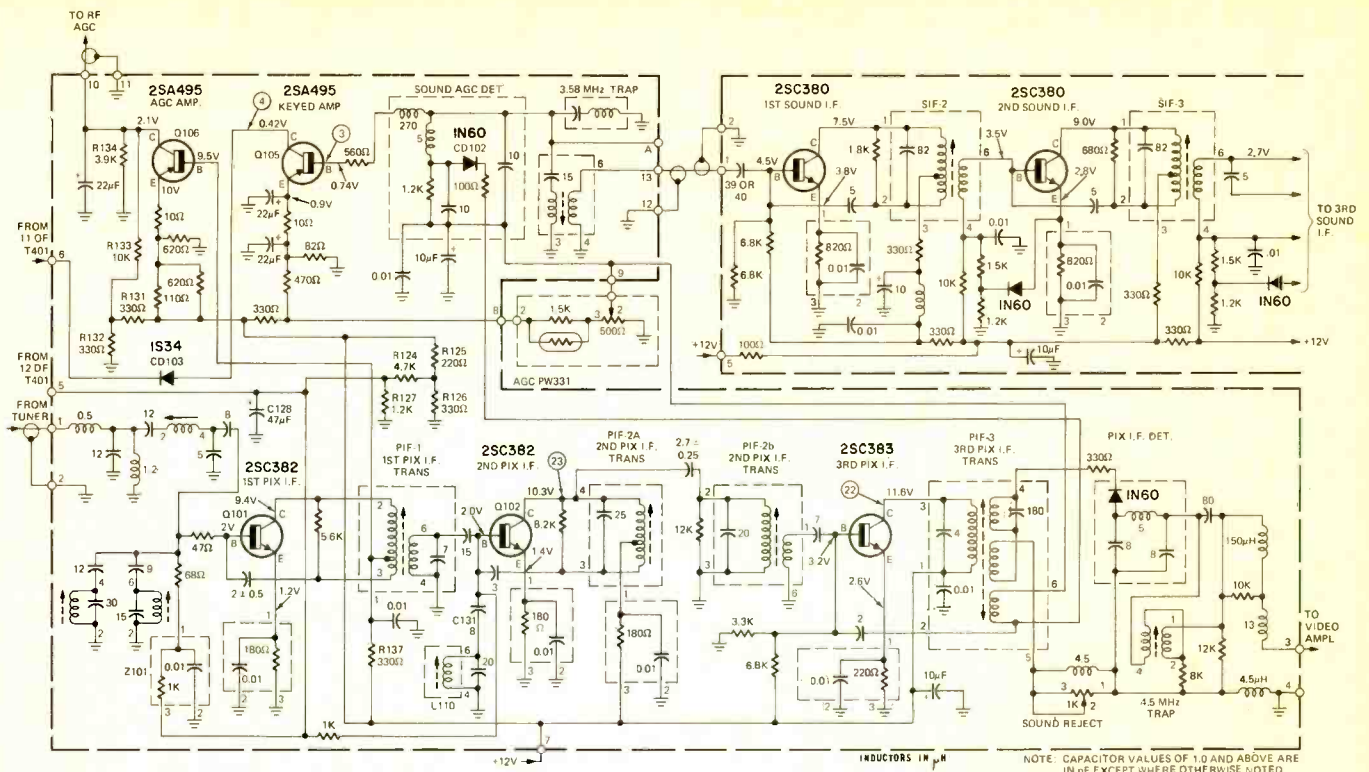

FIG. 2—TOSHIBA TAC-334 KEYED AGC and all positive biased output agc amplifier is a circuit not often seen in the United States.

RF TRANSISTOR ADJUST VR201 becomes less as Q201 conducts more. When the base of Q205 drops low enough, (11.2V as shown in Fig. 1) this delayed amplifier conducts positively and turns on emitter follower Q206. This transistor's positive output voltage will then increase proportionately to effectively forward bias any bipolar rf transistor in the tuner.

What if you had a FET? Reverse

tors and selected time constants. ANC Q208 is obviously used here as a fast switch that can only conduct negatively.

Toshiba's keyed agc

This is a somewhat different and more conventional *keyed* agc subsystem (Fig. 2), but just as interesting. The audio-video envelope is picked off the lower secondary of the third

12V p-p pulses appearing at the collector of Q105 are actually from the terminal 11 winding on the flyback transformer and are used to forward bias diode CD103 and supply collector potential for Q105.

As negative horizontal sync pulses from the transmitting station and flyback pulses from the receiver's high voltage section coincide, Q105 conducts positive current through CD103 and plug board terminal 6, back through flyback (T401) windings 11 and 12, with return through plug board terminal 5 to charge 47- μ F C128; developing voltage across R124 through R127—another approximately 30 msec time constant. Consequently, as the charge across C128 varies with the amplitude of incoming horizontal sync tips, forward bias is routed through Z101 and the top of C131, L110 to the bases of 1st pix. i.f. Q101 and second video i.f. Q102, respectively.

A positive bias agc rf amplifier

Sounds unusual? Certainly, but it works—as you will soon see. Forward bias for agc r.f. amplifier Q106 is from the centertap of the first video i.f. transistor across R137. Just as before, a considerable dc drop at this point will produce a less positive voltage to bias Q106 on. Note that this transistor has 10V at its emitter, 9.5V at its base and 2.1V at its collector—all dc voltages. With more negative-going input potentials, Q106 turns on more and its positive output increases. But how?

The same 12V power source sup-
(continued on page 68)

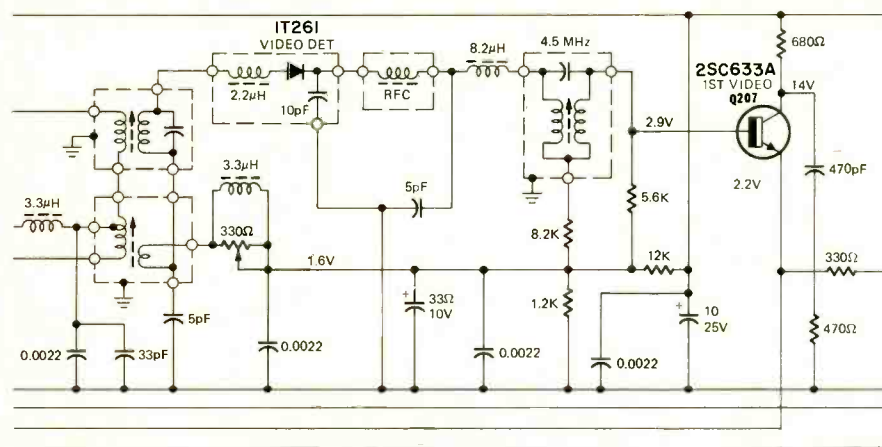

FIG. 1—SONY KV-1500 NOISE CANCELLER and peak defeating agc system. Look at it now and be prepared before you see one in your shop.

the Q206 connections and take the opposite output from its collector. FET's, you should know (or remember), take reverse and not forward bias to pinch off their normally conducting depletion-mode N channels. How does Sony now make its "peak" detection effective? Probably through the small propagation delays of its agc transis-

video i.f. transformer and germanium diode CD102 actually detects both agc sync and the difference beat of the 4.5-MHz intercarrier sound. Manufacturer's waveforms show a very small keyed amplifier Q105 base input and larger collector "output" both in negative phase. Therefore, there is no signal amplification, simply current. So



BUILD YOUR OWN BELL & HOWELL SOLID-STATE 25-INCH DIAGONAL COLOR TV!

It's an enjoyable way to learn new skills that could launch you on a brand-new career in electronics!

For free information, mail postage-free card today!

A complete at-home learning program in home entertainment electronics!

Get free information now about this complete, learn-at-home program in home entertainment electronics prepared for you by skilled instructors at Bell & Howell Schools.

Work on this exciting "hands on" project integrated into your learn-at-home program!

As part of your program, you build yourself a Bell & Howell solid-state color television set. This important project gives you "hands on" experience with solid-state circuitry—the kind of *practical* experience you'll need to build a successful career.

Attend special "help sessions" . . . talk to your instructors in person!

If you'd like some personal advice at any point in your program, you can arrange to attend a special "help session" and talk over special problems with a qualified Bell & Howell Schools instructor.

Master the most up-to-date solid-state circuitry

As color TV moves more and more in the direction of *total* solid-state circuitry, you'll be thoroughly familiar with the most advanced "trouble-shooting" techniques for these sophisticated circuits.

Fix stereo systems . . . FM-AM radios . . . phonographs . . . tape recorders

The thorough knowledge of electronics you gain from completing this course and building your own color TV set will be enough to service almost *any* type of home entertainment electronic device—even some that aren't on the market yet!

Find out how to earn extra part-time income — or start your own business!

We'd like to tell you all about this fascinating electronics program . . . and how you could build yourself a new future—full or part-time. Mail the attached card today so that our Bell & Howell Schools representative can bring you all the facts you need without obligation.

Exclusive Electro-Lab® electronics training system — yours to keep!

To make sure you get practical experience with instruments used daily by professionals, we've integrated into your program three precision instruments you assemble yourself: a Design Console, an Oscilloscope and a Transistorized Meter. (See details at right.)

For Free Information, Mail Card Today!

Electro-Lab® is a registered trademark of the Bell & Howell Company



25-inch picture (measured diagonally)

Detach postage-paid reply card and mail today for free information about . . .

■ Bell & Howell Solid-State 25-inch Diagonal Color TV:

Ultra-rectangular tube • 25-inch picture measured diagonally • full 315 sq. inch viewing area • solid-state modular circuitry • 4 advanced IC's • 100 transistors • 72 diodes • individual plug-in circuit boards • special UHF/VHF tuning features • built-in self-service components.

■ **Design Console:** "Breadboard" circuits without soldering for both solid-state and vacuum tube experiments • patented modular connectors • transistorized dual-range regulated DC power supply • 12.6 volt center tapped AC power supply • sine and square wave signal generator • test speaker.

■ **Oscilloscope:** Professional technician's diagnostic instrument • 5-inch screen • wide-band • sharp screen images • calibrated for peak-to-peak voltage and time measurements • 3-way jacks for leads, plugs, wires.

■ **Transistorized Voltmeter:** Measures current, voltage, resistance on large dial • combines vacuum-tube voltmeter with multimeter • sensitive, 4-inch, jewel-bearing d'Arsonval movement.

PLUS . . . with your first lesson, you get the Laboratory Starter Kit: a volt-ohm-meter (VOM) with design panels • modular connectors • experimental parts • battery power source. Gives you immediate "hands on" experience with your very first lesson.

If card has been removed, write:

An Electronics Home Study School

DeVRY INSTITUTE OF TECHNOLOGY

ONE OF THE

BELL & HOWELL SCHOOLS

4141 Belmont, Chicago, Illinois 60641



524R

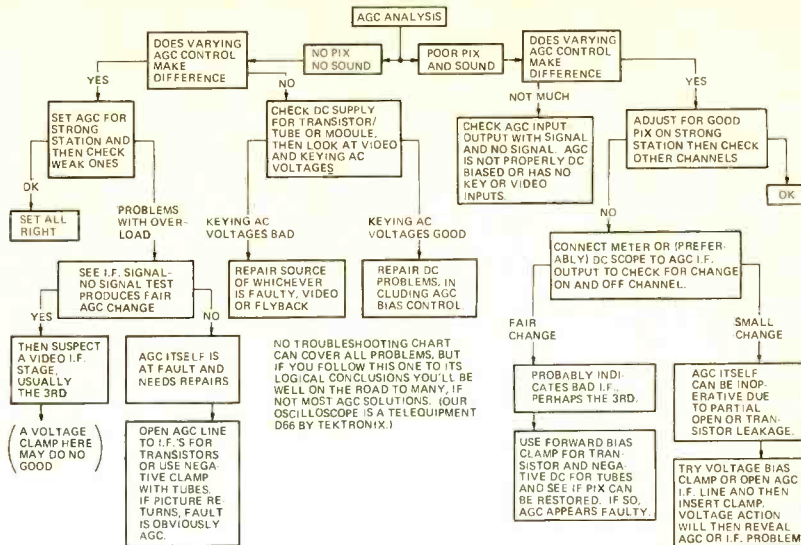

NO TROUBLESHOOTING CHART can cover all problems, but if you follow this one to its conclusions you'll be on the road to most agc solutions.

plies the Q106 collector and emitter. R131 and R132 are both 330-ohm resistors, and equal resistors divide the supply voltage in half, or 6 volts. Then voltage divider R133 and R134 again drops this 6V to 1.68V since $E_o = (6V \times 3.9K)/(3.9K + 10K)$. Obviously, the agc rf amplifier is conducting since its collector reading is 2.1V. As Q106's base input increases, this transistor becomes more and more a variable resistor, shunting R133 and delivering greater positive potential to its collector because of *decreased* collector load resistance; and, therefore, the *bipolar* rf transistor is forward bias-controlled to reduce its ac output.

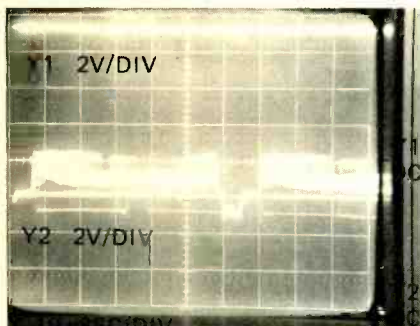

FIG. 3—VIDEO-SYNC INPUT (lower trace) and agc i.f. output. These waveforms seen when receiver operates normally.

Troubleshooting agc circuits

By now, one hopes you've become a firm believer—it's written in the book! It's also true that the amplitude of sync pulse tips are constant as broadcast from the television station—with no interruptions—and constitute about 30% of any fully modulated waveform, from zero (carrier cutoff) at the transmitter to zero (peak white) at the receiver. Therefore, under ordinary circumstances, there's very little change in agc output unless the entire composite waveform (including horizontal sync peaks) is disturbed by changing signal conditions. Keyed agc was initially developed to overcome

signal noise interruptions and to respond very quickly so that video-sync amplitude variations could be acted upon rapidly and provoke as little line scan interruption as possible. The old brute force method turned out to be an average, rather than line-by-line amplitude assessment and would react quite slowly, perhaps not too much over the entire 16.664 msec length of a complete field.

Today, however, with keyed and peak detection, reactions will be rapid and securely lock the dc loop that must either be broken and/or the entire circuit thoroughly analyzed before any agc problem can be solved. A large capacitor to ground from the flyback has been suggested as a way to shunt the agc keying pulse, but some newer sets will have their vertical circuits affected by this too, and certainly many receivers of all types use this same pulse for color sync keying as well. So let's get back to tried and true methods and we can't go wrong. First, understand the circuit . . . then in vacuum tube sets, *clamp* the agc bus to the video i.f. with a negative bias and vary this with received station signal to see if you can bring the set to life. In solid-state receivers, find some means (even pulling an agc transistor) to open the connection to the i.f. transistors (or IC), and use increasing positive forward bias to try and put video on the screen. You may also select an off channel to check maximum rf and i.f. gain. We'll show variations in the troubleshooting chart, but these are the fundamentals for them all.

Fig. 3 is a typical composite video input waveform with well-defined sync pulse, feeding an i.f. agc amplifier. At 2V/div. it's riding around 6V at a p-p amplitude of 3V. Its dc output voltage, however, is a normal 7.2V, and will remain at about this level unless the amplitude of the horizontal sync tips are disturbed. However, try cocking the tuner off channel, which simulates

an agc or i.f., rf failure. Obviously there is no incoming video, its dc voltage rises slightly, and the incoming "signal" is simply noise. But look what's happened to the forward i.f. agc! It's decreased from 7.2V positive to a nominal 6V, and that's where it stays! As you can readily see, both ac and dc voltages must be together in this agc system for it to work. Just ask your nearest, trusty oscilloscope. **R-E**

R-E's substitution guide for replacement transistors

PART IX

compiled by **ROBERT & ELIZABETH SCOTT**

- ARCH**—Indicates the Archer brand of semiconductors sold only by Radio Shack and Allied Radio stores. Allied Radio Shack, 2725 W. 7th St., Ft. Worth, Texas 76107
- DM**—D. M. Semiconductor Co., P.O. Box 131, Melrose, Mass. 02176
- GE**—General Electric Co., Tube Product Div., Owensboro, Ky. 42301
- ICC**—International Components, 10 Daniel Street, Farmingdale, N.Y. 11735
- IR**—International Rectifier, Semiconductor Div., 233 Kansas St., El Segundo, Calif. 90245
- MAL**—Mallory Distributor Products Co., 101 S. Parker, Indianapolis, Ind. 46201
- MOT**—Motorola Semiconductors, Box 2963, Phoenix, Ariz. 85036
- RCA**—RCA Electronic Components, Harrison, N.J. 07029
- SPR**—Sprague Products Co., 65 Marshall St., North Adams, Mass. 01247
- SYL**—Sylvania Electric Corp., 100 1st Ave., Waltham, Mass. 02154
- ZEN**—Zenith Sales Co., 5600 W. Jarvis Ave., Chicago, Ill. 60648

Radio-Electronics has done its utmost to insure that the listings in this directory are as accurate and reliable as possible; however, no responsibility is assumed by Radio-Electronics for its use. We have used the latest manufacturers material available to us and have asked each manufacturer covered in the listing to check its accuracy. Where we have been supplied with corrections, we have updated the listing to include them. The first part of this Guide appeared in March 1973.

	ARCH	DM	G-E	ICC	IR	MAL	MOT	RCA	SPR	SYL	ZEN
2N1982	NA	T-233	GE-4	ICC-233	TR-03	PTC 106	HEP-233	SK 3012	NA	ECG 105	ZEN 327
2N1983	RS276-2009	T-53	GE-63	ICC-53	TR-21	PTC 123	HEP-53	SK 3124	RT-102	ECG 123A	ZEN 102
2N1984	RS276-2009	T-53	GE-63	ICC-53	TR-21	PTC 123	HEP-53	SK 3122	RT-102	ECG 123A	ZEN 102
2N1985	RS276-2009	T-53	GE-63	ICC-53	TR-21	PTC 123	HEP-53	SK 3122	RT-102	ECG 123A	ZEN 102
2N1986	RS276-2009	T-53	GE-18	ICC-53	TR-21	PTC 125	HEP-53	SK 3122	RT-102	ECG 123A	ZEN 102
2N1987	RS276-2009	T-53	GE-18	ICC-53	TR-21	PTC 125	HEP-53	SK 3122	RT-102	ECG 123A	ZEN 102
2N1988	RS276-2009	T-53	GE-20	ICC-53	TR-87	PTC 144	HEP-53	SK 3122	RT-102	ECG 123A	ZEN 102
2N1989	NA	T-56	GE-17	ICC-714	TR-87	PTC 144	HEP-714	SK 3039	RT-113	ECG 108	NA
2N1990	NA	T-714	GE-18	ICC-714	NA	PTC 123	HEP-714	NA	NA	NA	NA
2N1991	RS276-2021	T-51	GE-21	ICC-51	TR-19	PTC 127	HEP-51	SK 3114	RT-115	ECG 159	ZEN 101
2N1992	RS276-2009	T-50	GE-63	ICC-50	TR-19	PTC 144	HEP-50	SK 3122	RT-102	ECG 123A	ZEN 100
2N1993	RS276-2001	T-641	GE-5	ICC-641	TR-08	PTC 108	HEP-641	SK 3011	RT-119	ECG 101	ZEN 315
2N1994	NA	T-641	GE-5	ICC-641	NA	PTC 108	HEP-641	SK 3011	RT-119	ECG 101	NA
2N1995	NA	T-641	GE-8	ICC-641	NA	PTC 108	HEP-641	SK 3011	RT-119	ECG 101	NA
2N1996	NA	T-641	GE-5	ICC-641	NA	PTC 108	HEP-641	SK 3011	RT-119	ECG 101	NA
2N1997	RS276-2005	T-254	GE-2	ICC-254	NA	PTC 102	HEP-254	SK 3005	RT-118	ECG 100	ZEN 305
2N1998	RS276-2005	T-254	GE-2	ICC-254	NA	PTC 102	HEP-254	SK 3005	RT-118	ECG 100	ZEN 305
2N1999	NA	T-2	GE-1	ICC-2	NA	PTC 107	HEP-2	SK 3005	NA	ECG 160	ZEN 300
2N2000	RS276-2005	T-254	GE-1	ICC-254	NA	PTC 135	HEP-254	NA	RT-121	ECG 102A	ZEN 305
2N2001	RS276-2005	T-254	GE-1	ICC-254	NA	PTC 135	HEP-254	NA	RT-121	ECG 102A	ZEN 305
2N2002	RS276-2021	T-51	GE-21	ICC-51	TR-54	PTC 131	HEP-51	SK 3114	RT-115	ECG 159	ZEN 101
2N2003	RS276-2021	T-51	GE-21	ICC-51	TR-54	PTC 131	HEP-51	SK 3114	RT-115	ECG 159	ZEN 101
2N2004	RS276-2021	T-51	GE-21	ICC-51	TR-54	PTC 131	HEP-51	SK 3114	RT-115	ECG 159	ZEN 101
2N2005	RS276-2021	T-51	GE-21	ICC-51	TR-54	PTC 131	HEP-51	SK 3114	RT-115	ECG 159	ZEN 101
2N2006	RS276-2021	T-51	GE-21	ICC-51	TR-31	PTC 131	HEP-51	SK 3114	RT-115	ECG 159	ZEN 101
2N2007	RS276-2021	T-51	GE-21	ICC-51	TR-31	PTC 131	HEP-51	SK 3114	RT-115	ECG 159	ZEN 101
2N2008	NA	T-714	GE-18	ICC-714	NA	PTC 125	HEP-714	NA	NA	NA	NA
2N2009	NA	T-3	GE-9	ICC-R1101	NA	NA	HEP-R1101	NA	NA	NA	NA
2N2010	NA	SR-1002	NA	ICC-R1101	NA	NA	HEP-R1101	NA	NA	NA	NA
2N2011	NA	SR-1003	NA	ICC-R1102	NA	NA	HEP-R1102	NA	NA	NA	NA
2N2012	NA	SR-1005	NA	ICC-R1103	NA	NA	HEP-R1103	NA	NA	NA	NA
2N2013	NA	SR-1005 /3	NA	NA	NA	NA	NA	NA	NA	NA	NA
2N2014	NA	SR-1005 /4	NA	NA	NA	NA	NA	NA	NA	NA	NA
2N2015	NA	T-704	NA	NA	TR-36	NA	NA	NA	NA	NA	NA
2N2016	NA	T-704	NA	NA	TR-36	NA	NA	NA	NA	NA	NA
2N2017	RS276-2018	T-243	GE-63	ICC-243	IRTR-87	PTC 117	HEP-243	SK 3024	RT-114	ECG 128	NA
2N2022	NA	T-2	GE-1	ICC-2	TR-17	PTC 109	HEP-2	NA	NA	ECG 160	ZEN 300
2N2032	NA	T-704	GE-14	ICC-S5001	NA	NA	HEP-S5001	SK 3039	RT-113	ECG 108	NA
2N2033	NA	TS-3020	GE-66	ICC-S5000	NA	PTC 110	HEP-S5000	NA	NA	NA	NA
2N2034	NA	TS-3020	GE-66	ICC-S5000	NA	PTC 110	HEP-S5000	NA	NA	NA	NA
2N2035	NA	TS-3020	GE-66	ICC-S5000	NA	NA	HEP-S5000	NA	NA	NA	NA
2N2036	NA	TS-3020	GE-66	ICC-S5004	NA	NA	HEP-S5004	NA	NA	NA	NA
2N2038	RS276-2009	T-53	GE-18	ICC-53	TR-87	PTC 125	HEP-53	SK 3122	RT-102	ECG 123A	ZEN 102
2N2039	RS276-2009	T-53	GE-18	ICC-53	TR-87	PTC 125	HEP-53	SK 3122	RT-102	ECG 123A	ZEN 102
2N2040	RS276-2009	T-53	GE-18	ICC-53	TR-87	PTC 125	HEP-53	SK 3122	RT-102	ECG 123A	ZEN 102
2N2041	RS276-2009	T-53	GE-18	ICC-53	TR-87	PTC 125	HEP-53	SK 3122	RT-102	ECG 123A	ZEN 102
2N2048	NA	T-2	GE-9	ICC-2	TR-14	PTC 109	HEP-2	NA	NA	ECG 160	ZEN 300
2N2049	NA	T-714	GE-18	ICC-S3011	TR-87	NA	HEP-S3011	NA	NA	NA	NA
2N2059	RS276-2003	T-3	GE-1	3	TR-35	PTC 109	HEP-3	NA	NA	ECG 160	ZEN 301
2N2060	NA	T-714	GE-18	NA	TR-87	PTC 123	NA	NA	NA	NA	NA
2N2061	RS276-2006	T-230	NA	ICC-230	TR-01	PTC 105	HEP-230	SK 3009	RT-124	ECG 104	ZEN 325
2N2062	RS276-2006	T-230	NA	ICC-230	TR-01	PTC 105	HEP-230	SK 3009	RT-124	ECG 104	ZEN 325
2N2063	RS276-2006	T-230	NA	ICC-230	TR-01	PTC 105	HEP-230	SK 3009	RT-124	ECG 104	ZEN 325
2N2064	RS276-2006	T-230	NA	ICC-230	TR-01	PTC 105	HEP-230	SK 3009	RT-124	ECG 104	ZEN 325
2N2065	RS276-2006	T-232	NA	ICC-232	TR-35	PTC 105	HEP-232	SK 3009	RT-124	ECG 104	ZEN 326
2N2066	RS276-2006	T-232	NA	ICC-232	TR-35	PTC 105	HEP-232	SK 3009	RT-124	ECG 104	ZEN 326
2N2067	NA	T-230	GE-3	NA	TR-16	PTC 105	NA	SK 3009	RT-124	ECG 104	NA
2N2069	NA	T-230	GE-3	ICC-625	TR-01	PTC 114	HEP-625	SK 3009	RT-124	ECG 104	NA
2N2070	NA	T-230	GE-3	ICC-625	TR-01	PTC 114	HEP-625	SK 3009	RT-124	ECG 104	NA
2N2071	NA	T-230	GE-3	ICC-625	NA	NA	HEP-625	NA	NA	NA	NA
2N2072	NA	T-230	GE-3	ICC-625	NA	NA	HEP-625	NA	NA	NA	NA
2N2075	NA	T-233	GE-4	ICC-233	NA	PTC 106	HEP-233	SK 3012	NA	ECG 105	ZEN 327
2N2076	NA	T-233	GE-4	ICC-233	NA	PTC 106	HEP-233	SK 3012	NA	ECG 105	ZEN 327
2N2077	NA	T-231	GE-4	ICC-231/233	NA	PTC 106	HEP-231/233	SK 3012	NA	ECG 105	ZEN 327
2N2078	NA	T-231	GE-4	ICC-231/233	TR-03	PTC 106	HEP-231/233	SK 3012	NA	ECG 105	ZEN 327
2N2079	NA	T-233	GE-4	ICC-233	TR-03	PTC 106	HEP-233	SK 3012	NA	ECG 105	ZEN 327
2N2080	NA	T-231	GE-4	ICC-233	TR-03	PTC 106	HEP-233	SK 3012	NA	ECG 105	ZEN 327
2N2081	NA	T-231	GE-4	ICC-231/233	TR-03	PTC 106	HEP-231/233	SK 3012	NA	ECG 105	ZEN 327
2N2082	NA	T-231	GE-4	ICC-231/233	TR-03	PTC 106	HEP-231/233	SK 3012	NA	ECG 105	ZEN 327
2N2083	NA	T-2	GE-1	ICC-638	TR-17	PTC 109	HEP-638	NA	NA	ECG 160	NA
2N2084	RS276-2003	T-3	GE-9	ICC-3	TR-17	PTC 107	HEP-3	SK 3006	NA	ECG 160	ZEN 301
2N2085	RS276-2002	T-641	GE-59	ICC-641	TR-08	PTC 108	HEP-641	SK 3011	RT-119	ECG 101	ZEN 315
2N2086	NA	T-714	GE-18	NA	TR-87	PTC 144	HEP-714	NA	NA	NA	NA
2N2087	NA	T-714	GE-18	NA	TR-87	PTC 144	HEP-714	NA	NA	NA	NA
2N2089	RS276-2003	T-635	GE-50	ICC-635	TR-17	PTC 107	HEP-635	SK 3006	NA	ECG 126	ZEN 311
2N2090	RS276-2003	T-635	GE-50	ICC-635	TR-17	PTC 107	HEP-635	SK 3006	NA	ECG 126	ZEN 311
2N2091	RS276-2003	T-635	GE-50	ICC-635	TR-17	PTC 107	HEP-635	SK 3006	NA	ECG 160	ZEN 311
2N2092	RS276-2003	T-635	GE-50	ICC-635	TR-17	PTC 107	HEP-635	SK 3007	NA	ECG 126	ZEN 311
2N2093	RS276-2003	T-3	GE-50	ICC-3	TR-17	PTC 107	HEP-3	SK 3008	NA	ECG 160	ZEN 301
2N2094	RS276-2009	T-736	GE-18	ICC-736	IRTR-51	PTC 123	HEP-736	SK 3122	RT-102	ECG 123A	ZEN 120

NA = NOT AVAILABLE

(turn page)

ARCH DM G-E ICC IR MAL MOT RCA SPR SYL ZEN

2N2095	RS276-2009	T-736	GE-51	ICC-736	NA	NA	HEP-736	SK 3122	RT-102	ECG 123A	ZEN 120
2N2096	RS276-2009	T-736	GE-20	ICC-736	TR-17	NA	HEP-736	SK 3122	RT-102	ECG 123A	ZEN 120
2N2097	RS276-2009	T-736	GE-9	ICC-736	TR-17	PTC 107	HEP-736	SK 3122	RT-102	ECG 123A	ZEN 120
2N2098	NA	T-2	GE-51	ICC-2	TR-17	PTC 107	HEP-2	NA	NA	ECG 160	ZEN 300
2N2099	NA	T-2	GE-51	ICC-2	TR-17	PTC 107	HEP-2	NA	NA	ECG 160	ZEN 300
2N2100	NA	T-2	GE-51	ICC-2	TR-17	PTC 107	HEP-2	NA	NA	ECG 160	ZEN 300
2N2101	NA	NA	NA	NA	TR-26	NA	NA	NA	NA	NA	NA
2N2102	NA	T-714	GE-66	ICC-714	IRTR-87	PTC 144	HEP-714	SK 3024	RT-114	ECG 128	NA
2N2104	RS276-2021	T-51	NA	ICC-51	NA	PTC 127	HEP-51	SK 3114	RT-115	ECG 159	ZEN 101
2N2105	RS276-2021	T-51	NA	ICC-51	NA	PTC 127	HEP-51	SK 3114	RT-115	ECG 159	ZEN 101
2N2106	RS276-2018	T-243	GE-63	ICC-243	IRTR-87	PTC 117	HEP-243	SK 3024	RT-114	ECG 128	NA
2N2107	RS276-2018	T-243	GE-63	ICC-243	IRTR-87	PTC 117	HEP-243	SK 3024	RT-114	ECG 128	NA
2N2108	RS276-2018	T-243	GE-63	ICC-243	IRTR-87	PTC 117	HEP-243	SK 3024	RT-114	ECG 128	NA
2N2137	RS276-2006	T-230	NA	ICC-230	TR-01	PTC 114	HEP-230	SK 3009	RT-124	ECG 104	ZEN 325
2N2138	RS276-2006	T-230	GE-3	ICC-230	TR-16	PTC 114	HEP-230	SK 3009	RT-124	ECG 104	ZEN 325
2N2139	RS276-2006	T-232	NA	ICC-232	TR-16	PTC 105	HEP-232	SK 3009	RT-124	ECG 104	ZEN 326
2N2140	RS276-2006	T-232	NA	ICC-232	TR-16	PTC 105	HEP-232	SK 3009	RT-124	ECG 104	ZEN 326
2N2141	RS276-2006	T-232	NA	ICC-232	TR-16	PTC 105	HEP-232	SK 3009	RT-124	ECG 104	ZEN 326
2N2142	RS276-2006	T-230	GE-16	ICC-230	TR-16	PTC 114	HEP-230	SK 3009	RT-124	ECG 104	ZEN 325
2N2143	RS276-2006	T-232	GE-16	ICC-230/232	TR-16	PTC 114	HEP-230/232	SK 3009	RT-124	ECG 104	ZEN 325/326
2N2144	RS276-2006	T-232	GE-16	ICC-232	TR-16	PTC 105	HEP-232	SK 3009	RT-124	ECG 104	ZEN 326
2N2145	RS276-2006	T-232	GE-3	ICC-232	TR-16	PTC 105	HEP-232	SK 3009	RT-124	ECG 104	ZEN 326
2N2146	RS276-2006	T-232	GE-3	ICC-232	TR-16	PTC 105	HEP-232	SK 3009	RT-124	ECG 104	ZEN 326
2N2147	RS276-2006	T-232	GE-16	ICC-232	NA	PTC 138	HEP-232	SK 3014	RT-124	ECG 104	ZEN 326
2N2148	RS276-2006	T-232	GE-16	ICC-232	TR-01	PTC 138	HEP-232	SK 3014	RT-127	ECG 121	ZEN 326
2N2152	NA	T-231	GE-4	ICC-231/233	TR-03	PTC 106	HEP-231/233	SK 3012	NA	ECG 213	ZEN 327
2N2153	NA	T-237	GE-4	ICC-237	TR-03	PTC 106	HEP-237	SK 3012	NA	ECG 213	NA
2N2154	NA	T-237	GE-4	ICC-237	TR-03	PTC 106	HEP-237	SK 3012	NA	ECG 213	NA
2N2155	NA	T-237	GE-4	ICC-237	TR-03	PTC 106	HEP-237	SK 3012	NA	ECG 105	NA
2N2156	NA	T-237	GE-4	ICC-237	TR-03	PTC 106	HEP-237	SK 3012	NA	ECG 213	NA
2N2157	NA	T-237	GE-4	ICC-237	TR-03	PTC 106	HEP-237	SK 3012	NA	ECG 104	NA
2N2158	NA	T-237	GE-4	ICC-237	TR-03	PTC 106	HEP-237	SK 3012	NA	ECG 213	NA
2N2159	NA	T-233	GE-4	ICC-233	TR-03	PTC 106	HEP-233	SK 3012	NA	ECG 105	ZEN 327
2N2160	RS276-2029	T-310	NA	ICC-310	IR-2160	NA	HEP-310	NA	NA	ECG 6400	ZEN 129
2N2161	RS276-2009	T-53	NA	ICC-53	IRTR-51	PTC 123	HEP-53	SK 3122	RT-102	ECG 123A	ZEN 102
2N2162	RS276-2021	T-51	GE-21	ICC-51	TR-19	PTC 131	HEP-51	SK 3114	RT-115	ECG 159	ZEN 101
2N2163	RS276-2021	T-51	GE-22	ICC-51	TR-19	PTC 131	HEP-51	SK 3114	RT-115	ECG 159	ZEN 101
2N2164	RS276-2021	T-51	GE-22	ICC-51	TR-19	PTC 131	HEP-51	SK 3118	RT-115	ECG 159	ZEN 101
2N2165	RS276-2021	T-51	GE-21	ICC-51	TR-19	PTC 131	HEP-51	SK 3114	RT-115	ECG 159	ZEN 101
2N2166	RS276-2021	T-51	GE-22	ICC-51	TR-19	PTC 131	HEP-51	SK 3114	RT-115	ECG 159	ZEN 101
2N2167	RS276-2021	T-51	GE-22	ICC-51	TR-19	PTC 131	HEP-51	SK 3114	RT-115	ECG 159	ZEN 101
2N2168	NA	T-2	GE-9	ICC-2	TR-17	PTC 107	HEP-2	NA	NA	ECG 160	ZEN 300
2N2169	NA	T-2	GE-9	ICC-2	TR-17	PTC 107	HEP-2	NA	NA	ECG 160	ZEN 300
2N2170	NA	T-2	GE-9	ICC-2	TR-17	PTC 107	HEP-2	NA	NA	ECG 160	ZEN 300
2N2171	RS276-2005	T-254	GE-1	ICC-254	TR-05	PTC 102	HEP-254	SK 3005	RT-118	ECG 100	ZEN 305
2N2172	RS276-2005	T-254	GE-1	ICC-254	TR-05	PTC 102	HEP-254	SK 3005	RT-118	ECG 100	ZEN 305
2N2173	RS276-2004	T-253	GE-2	ICC-253	TR-05	PTC 135	HEP-253	NA	RT-121	ECG 102A	ZEN 304
2N2175	RS276-2005	T-251	GE-22	ICC-251	TR-30	PTC 103	HEP-251	SK 3118	RT-126	ECG 106	ZEN 303
2N2176	RS276-2005	T-251	GE-22	ICC-251	TR-30	PTC 103	HEP-251	SK 3118	RT-126	ECG 106	ZEN 303
2N2177	RS276-2005	T-251	GE-22	ICC-251	TR-30	PTC 103	HEP-251	SK 3118	RT-126	ECG 106	ZEN 303
2N2178	RS276-2023	T-252	GE-22	ICC-252	TR-30	PTC 103	HEP-252	SK 3114	RT-115	ECG 159	NA
2N2180	RS276-2003	T-3	GE-1	ICC-3	TR-12	PTC 109	HEP-3	NA	NA	ECG 126	ZEN 301
2N2181	RS276-2021	T-51	NA	ICC-51	TR-30	PTC 131	HEP-51	SK 3114	NA	ECG 159	ZEN 101
2N2182	RS276-2021	T-51	NA	ICC-51	TR-30	PTC 131	HEP-51	SK 3114	RT-115	ECG 159	ZEN 101
2N2183	RS276-2023	T-52	GE-21	ICC-52	NA	PTC 103	HEP-52	SK 3114	RT-115	ECG 159	NA
2N2184	RS276-2023	T-52	GE-21	ICC-52	TR-30	PTC 103	HEP-52	SK 3114	RT-115	ECG 159	NA
2N2185	RS276-2023	T-52	GE-21	ICC-52	TR-30	PTC 131	HEP-52	SK 3114	RT-115	ECG 159	NA
2N2186	RS276-2023	T-52	GE-21	ICC-52	TR-30	PTC 131	HEP-52	SK 3114	RT-115	ECG 159	NA
2N2187	RS276-2023	T-52	GE-21	ICC-52	TR-30	PTC 131	HEP-52	SK 3114	RT-115	ECG 159	NA
2N2188	NA	T-2	GE-9	ICC-2	TR-17	PTC 102	HEP-2	SK 3006	NA	ECG 160	ZEN 300
2N2189	NA	T-2	GE-9	ICC-2	TR-17	PTC 102	HEP-2	SK 3006	NA	ECG 160	ZEN 300
2N2190	NA	T-2	GE-9	ICC-2	TR-17	PTC 102	HEP-2	SK 3006	NA	ECG 160	ZEN 300
2N2191	NA	T-2	GE-9	ICC-2	TR-17	PTC 102	HEP-2	SK 3006	NA	ECG 160	ZEN 300
2N2192	NA	TS-3001	GE-63	ICC-S3001	TR-17	PTC 133	HEP-S3001	SK 3039	RT-113	ECG 108	NA
2N2193	NA	T-729	GE-17	NA	TR-87	PTC 144	HEP-S3011	SK 3039	RT-113	ECG 108	NA
2N2194	RS276-2009	T-53	GE-63	ICC-53	TR-87	PTC 136	HEP-53	SK 3122	RT-102	ECG 123A	ZEN 102
2N2195	NA	TS-3020	GE-63	NA	TR-87	PTC 144	HEP-S3001	SK 3039	RT-113	ECG 108	NA
2N2196	NA	T-729	GE-17	NA	TR-72	PTC 133	HEP-S3020	SK 3039	RT-113	ECG 108	NA
2N2197	NA	T-729	GE-17	NA	TR-72	PTC 133	HEP-S3020	SK 3039	RT-113	ECG 108	NA
2N2198	NA	T-714	GE-18	NA	TR-87	PTC 125	HEP-713	SK 3124	RT-100	ECG 123	NA
2N2199	NA	T-2	GE-9	ICC-2	NA	PTC 107	HEP-2	NA	NA	ECG 160	ZEN 300
2N2200	NA	T-2	GE-51	ICC-2	NA	PTC 107	HEP-2	NA	NA	ECG 160	ZEN 300
2N2201	NA	NA	NA	NA	NA	NA	HEP-714	NA	NA	NA	NA
2N2202	NA	NA	NA	NA	TR-87	NA	HEP-714	NA	NA	NA	NA
2N2203	NA	NA	NA	NA	TR-87	NA	HEP-714	NA	NA	NA	NA
2N2204	NA	T-240	GE-12	NA	TR-87	PTC 104	HEP-714	SK 3021	RT-128	ECG 124	NA
2N2205	RS276-2009	T-50	GE-20	ICC-50	TR-53	PTC 123	HEP-50	SK 3124	RT-102	ECG 123A	ZEN 100
2N2206	RS276-2009	T-50	GE-20	ICC-50	TR-53	PTC 123	HEP-50	SK 3122	RT-102	ECG 123A	ZEN 100
2N2207	NA	T-638	GE-9	ICC-638	NA	PTC 107	HEP-638	SK 3006	NA	ECG 126	ZEN 313
2N2208	RS276-2003	T-635	GE-1	ICC-635	TR-12	PTC 109	HEP-635	SK 3006	NA	ECG 126	ZEN 311

NA = NOT AVAILABLE

(continued next month)

SERVICING RECORD CHANGERS

(continued from page 53)

wheel. Replace the retaining C clip and any trim you might have had to remove to gain access to the clip.

18. Refer to Fig. 2 and apply a single drop of lubricant to the over-arm shaft assembly. Work the arm up and down to insure proper lubrication.

OPTIONAL STEPS

19. Place 4 dowels, one under each corner to support the changer slightly off the bench. Connect the universal power cord to the changer and plug into an ac outlet. Place a strobe disc on the turntable and test for correct speed. The pattern should appear stationary.

20. Thoroughly clean the changer using a liquid spray cleaner for metal surfaces, and spray wax for the wooden surfaces.

21. Replace the changer in the unit and performance test. If any problems are noted consult trouble chart (Table II).

The complete changer just described requires about 45-minutes. While these simple overhaul techniques will solve about 80% of your record-changer problems, Table II gives you additional hints for servicing problems.

R-E

ACTIVE FILTERS

(continued from page 44)

are just as easy to do.

Bandpass designs

Bandpass filters are generally much harder to design and more subtle to use. About all we have room for here is to show you two circuits that will do the job (see Fig. 7). They're shown for any Q at a center frequency of 1 kHz. And here in Fig. 8 are the same circuits for a Q=8: (1 kHz)

The two-amplifier job requires far less stable gain and works better for higher Q's and higher frequencies. Either circuit gives you the equivalent of a single series "pole" or tuned RLC circuit. This circuit, like its passive counterpart has a nasty feature that you must allow for. Its response starts falling off very steeply either side of resonance, but for very low or very high frequencies, it

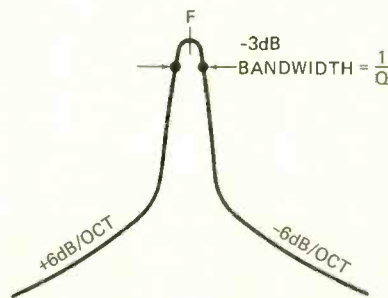

FIG. 9—BANDPASS RESPONSE CURVE measured at 3-dB point depends on circuit Q.

falls off at a more gradual rate of six decibels per octave. The response shape looks like the diagram in Fig. 9.

Normally, you cascade several poles to get the desired bandpass response. If we put the poles on top of one another, we get a very sharp response that is not very flat in the passband. We can control the response shape by staggering the poles in frequency and by altering their Q. Spreading the poles flattens out the passband, until finally you get a dip in the middle if you go too far. Another more formal way to design is to build a lowpass filter that does the job you want and then use a math process called *transformation* to get the desired bandpass shape. When you only need two poles, the simplest thing is to sit down with a breadboard and experiment with the Q and staggering for the response you need (the circuit moves around just like the low-pass and bandpass ones do by simultaneously changing capacitors or resistors); this is also a trivial problem for any computer that speaks BASIC, but the math is a bear otherwise. That's about all the details on bandpass design we have room for here. If enough readers are interested, we can put together another story with complete design curves for the two-pole bandpass designs in some other issue.

R-E

BUILD IN ACTIVE FILTER

Next month in Radio-Electronics Don Lancaster presents complete details on how to build an active filter to meet your own needs. Don't miss it.

The Mark Ten B Capacitive Discharge Ignition System keeps your car in tune ... and everyone knows that a well-tuned car gets better mileage, requires less maintenance, runs longer and better, and helps in the quest for cleaner air.



... Just ask Detroit and the E.P.A.

Circle 14 on reader service card

Order your Mark Ten B today! Please send me free literature.

Enclosed is \$ _____ Ship ppd. Ship C.O.D.
 Please Send: _____ Mark Ten B @ \$59.95 ppd. _____ Mark Ten B Kit @ \$44.95 ppd.
 Car Year _____ Make _____
 Name _____
 Address _____
 City _____ State _____ Zip _____

DELTA PRODUCTS, INC.

Dept. RE - P.O. Box 1147 - Grand Junction, Colo. 80501 (303) 242-9000



R-E's Service Clinic

The customer was right— Color is a mess!

Messy color is a problem that requires a logical attack

JACK DARR
SERVICE EDITOR

THE BLACK AND WHITE PICTURE IS clear, sharp and with good contrast. Yet the customer is telling the truth when he says, "The color is a mess!"

Turn the color control completely off; good picture. When it's turned up to normal, "mess" is the only word for it. Large, smooth colored objects, such as talking-heads, aren't too bad. Put a color-bar pattern on it, and this doesn't look too bad, either. Yet on a long-shot of a crowd, where faces are about an inch or so in size, they show distinct vertical bands of red, green and blue, followed by colors ringing, and colored ghosts all over the place. For another confusing symptom, the grid waveforms on the picture tube look almost normal.

Now you could be in deep trouble. However, if you know what to look for, where to look for it, and above all *how* to look for it, it's not too bad.

Step No. 1: find out what *is* working, by plain old observation. The tuner, i.f., video stages, picture tube, agc, brightness, color, tint control, and the 3.58-MHz oscillator. (The oscillator must be working or we wouldn't get any color.) This is definitely *not* a loss of color sync, either.

So what's left? The bandpass amplifiers, and perhaps the demodulators. The last one is not too likely, since the rocker pattern on the picture tube grids usually shows that these are OK. So we are left with a problem in the bandpass amplifiers. Now, *what* is it, and what *kind* of a fault is it?

Reasoning will tell us. This is not a short-circuit. If it was, it would be more apt to kill the color signal entirely. So this is some kind of an *open circuit* (and not one in the signal-path, either; we have signals). Something in the color circuits is *ringing*. This causes the miscoloration, and the most significant clue of all, the ghosts which are present *only* in the color signals. Turn the color off, and they go away.

I said open circuit, because this must be caused by something which is

open, and not affecting dc voltages. One very good suspect is a bypass capacitor, like the one at the bottom of the bandpass-amplifier transformer primary in Fig. 1. It puts the bottom

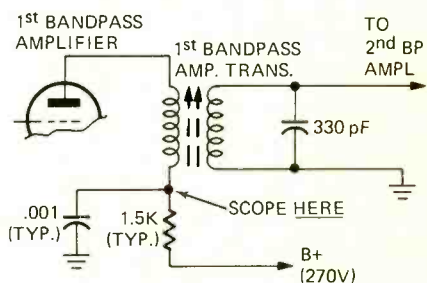

FIGURE 1

of this winding at ac ground potential. If it's open, this sets up a feedback loop, the transformer rings, and away we go.

Simple test; put the scope probe right on the bypass capacitor. At the high frequency of the color signal, it doesn't take a very large capacitor to bypass it. Somewhere from a .001 μF to a .01 μF is common. If you see *anything* at all in the way of a signal at this point, look out. The bypass capacitor isn't doing the job. Turn the scope gain up as high as you can. It doesn't take very much feedback signal to upset things for three feet in all directions.

Want to double check? Bridge a good capacitor across this one, and see if it changes the symptoms. Should have no effect at all, if the junction is properly bypassed. Check all bypassed points like this. In some sets using transformers in the demodulators, check their bypassing, too. In one set, an open bypass on a demodulator transformer caused the screen to turn half gold and half blue.

That's one. Another is a defective winding on one of the bandpass amp transformers. This won't be an open winding, in transformers which have only two windings without taps. This would break the signal-path, and

(continued on page 78)

This column is for your service problems—TV, radio, audio or general and industrial electronics. We answer all questions individually by mail, free of charge, and the more interesting ones will be printed here.

If you're really stuck, write us. We'll do our best to help you. Don't forget to enclose a stamped, self-addressed envelope. Write: Service Editor, Radio-Electronics, 200 Park Ave. South, New York 10003.

Announcing the Panasonic Parts Hot Line.

In 48 hours we can ship you anything we've got.

The New Panasonic Parts Hot Line is a performance promise: 24-hour-a-day, 7-day-a-week service. Now, if you have a problem getting the part you need, just call one central number.

Then things start happening fast: we'll ask our computer to locate your part (or parts) by searching all five regional Panasonic parts depots. In just seconds. Electronically. Then we'll telex an order to the depot which has the part you need and within

48 hours, your order is on its way.* And we can make this promise with confidence, because our warehouses are now fully automated. We've got the 2,000 fastest moving parts on electronic order pickers. At the touch of a button any of these high traffic parts is at our fingertips.

To become a member of the Panasonic Parts Hot Line, call the toll-free number below. We'll send you a bright red emblem imprinted with the hot line num-

ber for your particular region. We'll also send you an easy-reference booklet that gives you the names of authorized Panasonic parts distributors in your area, and information on other Parts Division services.

We know that your business depends upon having the right parts at the right time — when your customer needs them. Our business is standing right behind your business, with quality parts for over 1,000 products.



Panasonic
Parts
Hot Line
8-4712

Panasonic
just slightly ahead of our time

Call toll-free anywhere in the U.S. 800-523-5336. (in Pa. 800-523-5395)

*Not available in some areas. Not available on weekends and holidays.

www.americanradiohistory.com

PUT IT ALL TOGETHER

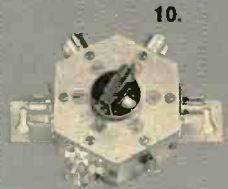
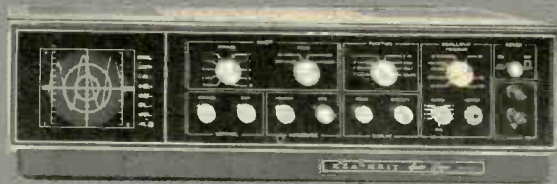
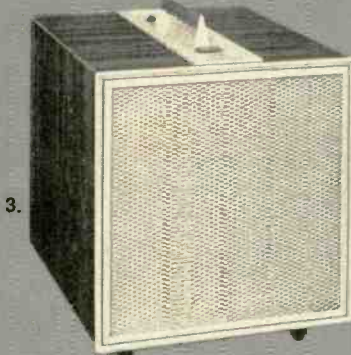
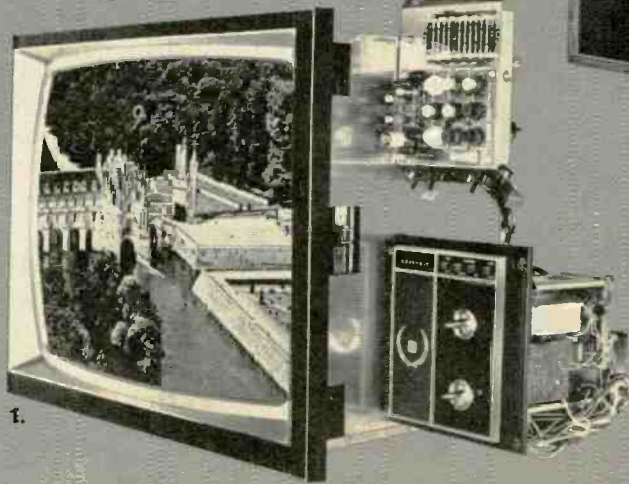
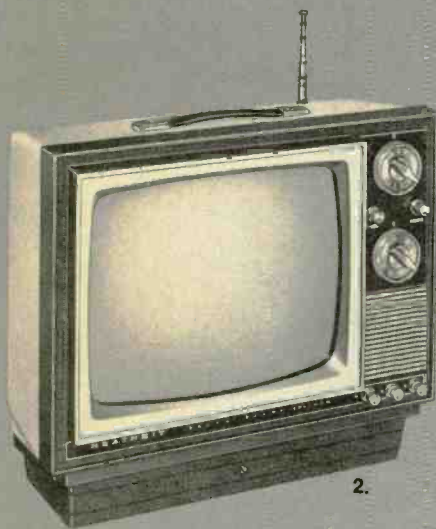

Build Heathkit quality electronics and create a whole house full of personal accomplishments. Plus you'll often save considerably over the cost of comparable products, then save again because Heathkit designs include built-in self-service features.

Heathkit building is unbelievably easy. In fact, we stake our reputation on the idea that you can build any kit you see on these pages. Even if you have never assembled a kit product before. All you need are conventional hand tools and a soldering iron. The assembly manuals tell you how and when to use them — step-by-step from start to successful completion.

And of course every kit is backed up by the Heath Plain Language Warranty and our pledge that — whatever the problem, whatever the reason — "we won't let you fail".

1. GR-900 25V Color Television \$599.95* (less cabinet)

The most advanced circuitry Heath has ever offered. Push-button power tuning locks-in on any 12 preselected UHF channels, all VHF stations. Along with the largest color screen in the industry, you get angular tint control to reduce flesh-tone change between channels, instant on, automatic fine tuning, adjustable tone control, hi/hi audio output jacks, and exclusive Heath self-service built-ins. Shipping weight, 125 lbs.

2. NEW GR-104C Portable Black & White TV \$129.95*

Now the ultimate portable TV has positive detent tuning on all 72 UHF channels as well as VHF. All solid-state circuitry, plus brilliant 12V shell bond picture tube puts black & white entertainment anywhere. Plugs into wall outlet, or runs from 12-volt DC automotive system with adapter included — or becomes completely self-contained with optional rechargeable battery-pack base. Mailing weight, 35 lbs. Optional GRA-104-3 battery pack 42.95*, 9 lbs. Outdoor Sun Shield GRA-104-2, 1.95*, 1 lb.

3. NEW GD-1003 Electronic Air Purifier \$139.95*

An easy-to-build 3-evening project. Removes 99% of airborne pollen and 95% of all other contaminants. Has 2-stage electronic operation; washable collector cell; replaceable charcoal filter; 2-speed fan; attractive walnut and gold finish. Purifies air in 20' x 20' room in minutes. Mailing weight, 55 lbs.

4. NEW AS-1039 Ultra-efficient Speaker System \$44.95*

Just 5 watts drives it to booming volume. Uses 8-in. woofer in vented bass reflex enclosure and exponential rectangular horn tweeter with separate level control. Response, 70 to 15,000 Hz. Impedance, 8 ohms. Maximum input 25 watts. Walnut-tone vinyl covered cabinet and green, brown and gold grille board shipped assembled. Measures 21" H x 12" W x 10½" D. Mailing weight, 36 lbs.

5. NEW AS-1042 Acoustic Suspension Speaker \$34.95*

Uses 8" long throw woofer and 3½" shallow cone/dome tweeter for flat frequency response from 40 to 18,000 Hz. External high-frequency control tailors the "highs" to your environment. Requires as little as 10 watts, can handle up to 25. 8 ohms impedance. Walnut-tone vinyl covered cabinet and brown and black grille board shipped pre-assembled. Measures 19" H x 10" W x 8¼" D. Mailing weight, 27 lbs.

6. NEW GD-3209A Deluxe Garage Door Opener \$139.95*

Ultra-quiet, ultra-reliable screw drive system that you can build and install over a weekend. All electronics shipped

pre-assembled. Has ¼-hp motor, automatic safety reversing plus adjustable slip clutch, automatic time delay light, external adjusting knobs for up/down travel. Includes 1 transmitter. GD-3209B, same as above with 2 transmitters, 154.95*. Mailing weight, 66 lbs. For jamb & pivot doors and GDA-3209-2 adapter, 14.95*, 7 lbs.

7. NEW AD-1013 4-Channel Audio-Scope \$199.95*

A sophisticated solid-state oscilloscope designed for monitoring the home audio system. Displays stereo or 4-channel signals for separation, phasing, relative strength, multipath reception, center tuning, etc. Has exclusive triggered sweep for stable, jitter-free trace. Designed to complement Heathkit AR-1500 Receiver. Mailing weight, 19 lbs. AR-15 and AJ-15 owners, add ARA-15-1 adapter, 24.95*, 1 lb.

8. NEW GD-1018 Solid-state Lamp Dimmer \$7.95*

Controls lamp brightness from full illumination through mood-setting dimness to complete invisibility. For single and multiple lamps not exceeding 300 watts total. Extends filament life, eliminates the need for costly 3-way bulbs. A great starter kit. Can be assembled easily in 1 evening. Mailing weight, 2 lbs.

9. NEW CM-1045 Small-engine Tune-up Meter \$39.95*

Solid-state tach/dwell/volt/ohm meter for all 2 and 4 cycle engines, 1 through 4 cylinders. In many cases permits checking entire small-engine ignition without tearing down flywheel assembly. Built-in tachometer has handy snap-on inductive pickup, reads from 0-3000, 0-15000 rpm. Completely portable, uses 3 1.5-volt batteries (not supplied). Mailing weight, 5 lbs.

10. NEW HD-1234 Coaxial Switch \$9.95*

A neat accessory for the amateur radio enthusiast. Designed to switch one RF source to any one of several antennas or RF loads while grounding the unused outputs. Two switches can be used to switch up to four antennas/loads to four different components. Standing wave ratio is 250 MHz, 1.1:1 max. Power capability is 1000 W (2000W PEP). Mailing weight, 2 lbs.

11. NEW GD-600 Photoelectric Lamp Switch \$5.00*

Low-cost home protection in a simple, enjoyable kit. Solid-state circuitry turns light on at dusk, turns it off at dawn. Adjustable sensitivity control sets switch to operate at various levels of light and darkness. Can be used with single or multiple lamps not exceeding 300 watts total. Easy, single circuit board design can be assembled in 1 evening. Mailing weight, 1 lb.

Visit your nearest Heathkit Electronic Center... or send for FREE catalog

HEATHKIT ELECTRONIC CENTERS — ARIZ.: Phoenix; CALIF.: Anaheim, El Cerrito, Los Angeles, Pomona, Redwood City, San Diego (La Mesa), Woodland Hills; COLO.: Denver; CONN.: Hartford (Avon); FLA.: Miami (Hialeah); GA.: Atlanta; ILL.: Chicago, Downers Grove; IND.: Indianapolis; KANSAS: Kansas City (Mission); MD.: Baltimore, Rockville; MASS.: Boston (Wellesley); MICH.: Detroit; MINN.: Minneapolis (Hopkins); MO.: St. Louis; N.J.: Fair Lawn; N.Y.: Buffalo (Amherst), New York City, Jericho, L.I., Rochester; OHIO: Cincinnati (Woodlawn), Cleveland; PA.: Philadelphia, Pittsburgh; R.I.: Providence (Warwick); TEXAS: Dallas, Houston; WASH.: Seattle; WIS.: Milwaukee.



World's largest selection of electronic kits

HEATH COMPANY, Dept. 20-11
Benton Harbor, Michigan 49022

Please send FREE Heathkit Catalog.

Enclosed is \$ _____, plus shipping.

Please send model(s) _____

Name _____

Address _____

City _____ State _____ Zip _____

* Mail order prices; F.O.B. factory.

HEATH

Schlumberger

CL-481

Circle 100 on reader service card

GOOD TOOLS!

15 Watt Miniature Plug-In Soldering Iron



ORYX — the tiny iron for service work, lab, production. Needs no transformer, weighs only an ounce plus cord. Heats so quickly — reaches 725° F in about a minute. Light weight, small size let you work all day without fatigue. Just the thing for tiny components, delicate circuits, working in close quarters. Many replaceable tips.

Controlled- Temperature Soldering Iron



ORYX Model 50 iron affords close control of temperature, from 400 to 750° F. 50-watt element gives fast heat, quick recovery from heavy joint loads. Temperature adjustable while iron is on. Ideal for semiconductors, delicate components that could be damaged by heat. Many replaceable tips, in various shapes, sizes.

Mini Vacuum Cleaner



Just the thing for clean rooms, production and assembly lines, service and repair shops, model shops and labs. For business machines, computers, getting eraser crumbs out of typewriters. Variety of nozzles and brushes, and special nozzle that gets into every nook and cranny. Internal filter keeps dust and dirt inside the vacuum.

Write today for
FREE
CATALOG!

Electronic Tools
& Test Instruments

TEL-52

**ORYX
TELVAC**

TELVAC
INSTRUMENT
COMPANY

14614 RAYMER STREET
VAN NUYS, CALIF. 91405

Circle 15 on reader service card

SERVICE CLINIC

(continued from page 72)

you'd probably have no color at all. This kind of problem will show up in circuits like those used in RCA CTC-39 and others, which have a tapped secondary winding on the bandpass transformers. One part of the winding can open, and the signal will still get through.

Since the normal impedance of the transformer is upset, it will ring.

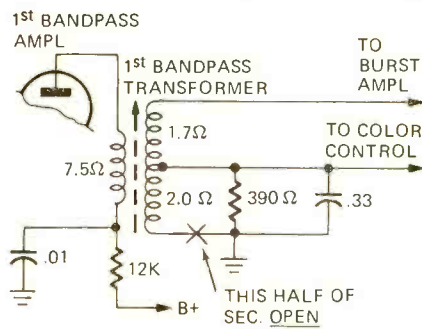

FIGURE 2

There's a very simple test for one of these; just grab the transformer with your fingertips. (Most of these are not shielded). If this causes the symptoms to change drastically, or even disappear completely, there you are. Check continuity of all windings, es-

pecially the secondary. Fig. 2 shows one of these.

Last one (although we'll probably find others later on). An *undamped* bandpass transformer winding. In some of the earlier sets, a damping resistor was connected across the secondary. If you happened to get the wrong bandpass transformer, it will fit the holes in the board, but the damping resistor will be hanging loose. Results; same old thing—transformer rings like a bell. Same check: grab the transformer between your fingers (see Fig. 3).

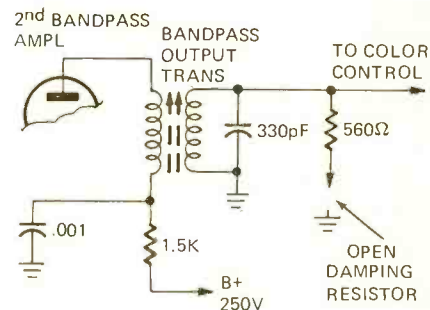

FIGURE 3

Although I haven't seen a verified case of this as yet, there would be a definite possibility of trouble if the center-tap of an output bandpass transformer secondary should either

(continued on page 80)

TEST RIG FOR TUBE & SOLID STATE

THE COMBO RIG
MODEL CJ-175

\$8995
less picture tube

- ELIMINATES HAULING CABINET & TUBE
- SPEEDS TROUBLE SHOOTING
- SERVICES TUBE & SOLID STATE

TELEMATIC TEST RIG CJ-175

CONSISTS OF:

- ★ Compact metal case
- ★ Universal Yoke
- ★ Convergence Yoke
- ★ Blue Lateral Magnet
- ★ Solid State Transverter
- ★ 4' Anode Extension
- ★ 4' 90 degree CRT Extension
- ★ 4' Yoke Extension
- ★ Convergence Load
- ★ 4 Yoke adaptors for Solid State



TeleMatic

Write us for free subscription of current cross-reference charts.
2245 Pitkin Avenue, Brooklyn, N.Y. 11207

Circle 16 on reader service card

SOUTHWEST TECHNICAL PRODUCTS CORPORATION

219 W. RHAPSODY

SAN ANTONIO, TEXAS 78216

PHONE: 512 DI 4-3140

November, 1973

Dear Radio-Electronics Readers,

This month I would like to tell you about another kit that we have sort of been keeping quiet about. Our new "Universal Digital Instrument." This instrument began life as Don Lancaster's "Digital Grinchwa!" in the Nov. 1972 issue of Radio-Electronics. With Don's help we have redesigned the package and made this into a really outstanding piece of test equipment. As you can see from the picture, we have put it in a rugged all steel case with an epoxy enamel finish. The power supply batteries are a larger size for increased battery life and best of all, we have mounted the connector pins for the two parts directly on the chassis to make this a true plug-in system. The capacity plug-in is shown in the picture. This is our kit No. UC-1 and the price is only \$24.95. The other plug-ins in the series will have similar crazy low prices due to the Mostek "divide by almost anything" programable divider (MK5009)



that is in the mainframe portion of this instrument. Since you have purchased the time base too when you bought the mainframe, and since the output of the timebase can be programmed by the plug-in module, many neat things can be done with the system. Would you believe a digital clock? Yes, even a digital clock with four decade counters and no modulo 6 ability. The mainframe is yours for only \$59.95. It features a full four (4) digit readout (not 2½ like others in this price range). This gets you everything you need except the batteries for the mainframe. Naturally this includes things like a G-10 fibreglass circuit board and first quality standard numbered parts. What else would you expect from us? In addition to this you get a huge (for us) nine page assembly and check out manual.

At this time we have Frequency Counter, Timebase, Timeperiod and Capacity plug-in modules. Available in the next few months will be a Volt-Ohmmeter, A-D Converter and Tach. Others are being planned. We feel that this kit should be an outstandingly useful instrument for anyone working with electronics.

Some of you out there have had a long wait for this kit, but now we think that suppliers have caught up enough, and our parts deliveries have gotten close enough to "on schedule" to let everyone have a chance to buy one of these. We also would be happy to send you a FREE catalog listing details on this and our other kits. Just drop us a card, or circle our number on the reader service card in the back of this magazine.

Sincerely,

Dan

Daniel Meyer

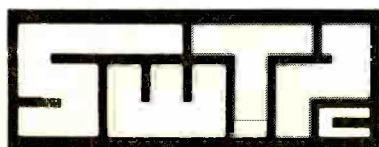

SOUTHWEST TECHNICAL PRODUCTS CORPORATION

DEPT. RE-L

219 W. RHAPSODY, SAN ANTONIO, TEXAS 78216

SERVICE CLINIC

(continued from page 78)

open or become ungrounded at a lug. The ohmmeter will catch any of these, as far as the open circuits is concerned.

There is also a possibility that one of the electrolytic capacitors in the dc voltage supply could allow the feedback loop to set up through the power supply. Check these with the scope, or by bridging, or both.

These are weird troubles; yet, if you know what to look for, and where to look, they're not at all hard to dig out and cure. **R-E**

reader questions

TAPE PLAYER WON'T CHANGE TRACKS

This auto-tape player will not change tracks. Even with the panel pushbutton, nothing happens.—W.H., Dunlap, Iowa

Most of these use a solenoid to move the head for track-changing. Check the dc voltage across the solenoid terminals while holding the

TRACK CHANGE button down. If you get voltage, disconnect the solenoid and check it for continuity. In several of these, you'll find a diode shunted across the coil, for transient suppression. If it shorts, the solenoid won't work.

VERTICAL TROUBLE

This Zenith 14N22 has a bad case of vertical foldover. What's the most likely cause and which capacitor in this circuit is the most critical?—R.M., Wellsburg, W.Va.

All of them. However, with foldover, the most likely one would be the coupling capacitor between the input-section plate and output-section grid. See if it's leaky.

LOST SYNC

This Magnavox U21 chassis won't stay in sync. If it's set up for a good picture, it soon loses sync, both vertical and horizontal. I need help.—J.B., Va. Beach, Va.

No, you need some sync. Since you are losing both vertical and horizontal sync, look for a loss of output in the stage that handles both; the sync separator. Check the amplitude of the composite sync output, on the plate of the 6AN8, or possibly the 12AU7 sync inverter. Also bridge that 30- μ F electrolytic on the +260 volt line.

IONIZERS AND AIR-CLEANERS

I want to build some things like ionizers, and electrostatic air cleaners. Where can I find parts for these?—A.B., Fremont, Ohio

The Triad Transformer Co., 305 N. Briant, Huntington, Ind. 46750, makes quite a few special high-voltage power supplies for such things. They'll be happy to send you a bulletin on them. As a matter of fact, the high-voltage power supply of a junked TV set could be used too.

NO RED SETUP LINE?

I have two "funnies". On a CTC-19 RCA chassis, I get no red line on the screen in Service position. Yet, I can get a bright red raster for purity, black and white picture good, color pix good. Pix guns check OK on tester.

I've also got an intermittent loss of the video signal, at the 12HG7 plate, but plenty at the grid. What gives?—J.B. New York, N.Y.

For the intermittent loss of video, check all of the solder joints on the PC board, between the 12HG7 plate and the pix tube cathodes. Peaking chokes, etc.

For the "No red line" symptom, FORGET IT! Since you have a good B/W picture, all three guns can conduct properly. If the color picture is good, this clears all color circuitry. Se-

TV TUNER SERVICE

PTS ELECTRONICS, INC.
also available in ...

MINNEAPOLIS — ST. PAUL

KANSAS CITY

NEW ORLEANS

WASHINGTON, D. C.

NEW YORK CITY

\$995

1 YEAR GUARANTEE

now you too... get Fast 8 hr. Service!

ALL PTS BRANCHES are wholly owned subsidiaries of PTS ELECTRONICS, INC. (NO FRANCHISES!) and report directly to the Home Office in Bloomington, Indiana. Only this way can we guarantee the same quality—PRECISION TUNER SERVICE—that made PTS the leader in this field.

PTS is proud to be the only tuner service to publish a TUNER REPLACEMENT PARTS CATALOG (80 pages of tuner blow-ups, tuner-antenna coil-and shaft replacement guides available for \$1.00).

WE OFFER MORE. SERVICE IS EVERYTHING WITH US.
WE ARE DYNAMIC AND FAST. TRUSTWORTHY.

YOU AND US — A TRUE PARTNERSHIP

Color • Black & White • Transistor
Tubes • Varactor • Detent UHF

All Makes

VHF, UHF or FM \$ 9.95

UV-COMBO 16.95

IF-SUBCHASSIS 12.50

Major parts and shipping
charged at cost.
(Dealer net!)

over 4000 exact tuner replacements available for \$15.95 up (new or rebuilt)

PTS ELECTRONICS, INC.

is recommended by more TV manufacturers and overhauls more tuners than all other tuner services combined!

for finer, faster.

Precision Tuner Service

send faulty unit with tubes, shields and all broken parts to

PTS

ELECTRONICS, INC.
1105 SPRING ST.
SILVER SPRING, MD. 20910
TEL. 301-565-0025

Circle 18 on reader service card

80 RADIO-ELECTRONICS • NOVEMBER 1973

PTS
ELECTRONICS, INC.

HOME OFFICE—INDIANA:
P.O. BOX 272
BLOOMINGTON, IND. 47401
TEL. 812-824-9331

CALIFORNIA—NORTH:
PTS ELECTRONICS, INC.
P.O. BOX 41354
SACRAMENTO, CALIF. 95841
TEL. 916-482-6290

CALIFORNIA—SOUTH:
PTS ELECTRONICS, INC.
P.O. BOX 5791
SAN DIEGO, CALIF. 92105
TEL. 714-280-7070

COLORADO:
PTS ELECTRONICS, INC.
P.O. BOX 472
ARVADA, COLO. 80001
TEL. 303-423-7080

FLORIDA:
PTS ELECTRONICS, INC.
P.O. BOX 1923
JACKSONVILLE, FLA. 32210
TEL. 904-389-9952

INDIANA:
PTS ELECTRONICS, INC.
P.O. BOX 272
BLOOMINGTON, IND. 47401
TEL. 812-824-9331

KANSAS:
PTS ELECTRONICS, INC.
3115 MERRIAM LANE
KANSAS CITY, KANSAS 66100
TEL. 913-811-1222

LOUISIANA:
PTS ELECTRONICS, INC.
P.O. BOX 73247
METairie, LA 70033
TEL. 504-885-2349

MARYLAND:
PTS ELECTRONICS, INC.
1105 SPRING ST.
SILVER SPRING, MD. 20910
TEL. 301-565-0025

MASSACHUSETTS:
PTS ELECTRONICS, INC.
P.O. BOX 3189
SPRINGFIELD, MASS. 01103
TEL. 413-734-2737

MINNESOTA:
PTS ELECTRONICS, INC.
815 W. LAKE ST.
MINNEAPOLIS, MINN. 55408
TEL. 612-824-2331

NEW YORK CITY—NEW JERSEY:
PTS ELECTRONICS, INC.
158 MARKET ST.
E. RUTHERFORD, N.J. 07047
TEL. 201-791-6380

OHIO:
PTS ELECTRONICS, INC.
5692 STATE RD.
CLEVELAND, OHIO 44134
TEL. 216-845-4480

OKLAHOMA:
PTS ELECTRONICS, INC.
P.O. BOX 30965
OKLAHOMA CITY, OKLA. 73106
TEL. 405-947-2013

OREGON:
PTS ELECTRONICS, INC.
P.O. BOX 13096
PORTLAND, OREGON 97213
TEL. 503-287-9636

PENNSYLVANIA—EAST:
PTS ELECTRONICS, INC.
P.O. BOX 16556
PHILADELPHIA, PA. 19142
TEL. 215-724-0999

PENNSYLVANIA—WEST:
PTS ELECTRONICS, INC.
P.O. BOX 4130
PITTSBURGH, PA. 15202
TEL. 412-761-7648

TEXAS—NORTH:
PTS ELECTRONICS, INC.
P.O. BOX 7332
LONGVIEW, TEX. 75601
TEL. 214-753-4334

TEXAS—EAST:
PTS ELECTRONICS, INC.
P.O. BOX 26616
HOUSTON, TEX. 77032
TEL. 713-644-6793

WASHINGTON, D.C.:
PTS ELECTRONICS, INC.
1105 SPRING ST.
SILVER SPRING, MD. 20910
TEL. 301-565-0025

www.americanradiohistory.com

riously speaking, this is probably an intermittent contact on the SERVICE switch. If everything else works, it's in fine shape.

VERTICAL RETRACE

I'm getting too much vertical-retrace line pattern on a Zenith 20Y1C38. With the brightness turned up quite a bit, it isn't too bad, but when the brightness is down to normal it is bad. Can't find it.—A.T., Schenectady, N.Y.

The vertical blanking in this chassis goes to the base of the 2nd video amplifier transistor. This is a busy little rascal: vertical blanking to its

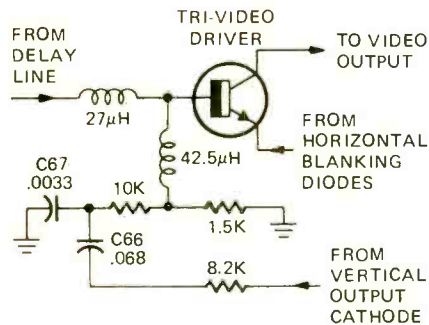

base, horizontal blanking to its emitter, and video straight through!

There's an RC network in the base circuit, going to the cathode of the 6HE5 vertical output tube (see diagram). Check these out; open C66 or leaky C67 will reduce the amplitude of the vertical blanking pulse. Also, check the 2nd video transistor for leakage.

VTVM DRIFT

My Heathkit IM-13 vtvm has a drift. When it's on dc volts, the meter needle slowly swings to the right, all the way off scale. Acts up on ac volts, also. The ohms scale seems to be OK.—E.N., Hensall, Ont.

The most likely cause for this would be an unbalanced "meter tube". This Heathkit uses the "meter between cathodes" circuit, standard in many VTVM's. If the two triodes of the tube have unequal emission, or grid emission, you'll get this kind of trouble.

Age a new 12AU7 tube, by letting it sit in the tube-tester all day with only the filament voltage on it. Then try it. Recalibrate the meter on dc volts as per the instructions. You might have to try one or two new tubes, but I doubt it. One good tube will usually do it.

I.F. TRANSISTORS OVERHEAT

The two i.f. transistors in this Sears (Toshiba) 12" color TV get hot and I lose video and audio in about a minute. Cooling them will bring it back, momentarily. New transistors didn't help; dc voltages are correct while it is work-

PAIA MAKES THE ONLY KIT SYNTHESIZER

MODELS PRICED
FROM \$139

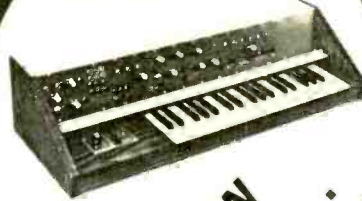

**but you know
we also have . . .**

THE SURF
A BIRD
THE WIND
PING-PONG
WIND CHIMES
DRUMMER BOY
STEAM WHISTLE
SYNTHESIZER II
A FAZE SCHIFTER
A CHATTER JAMMER
INFINITY PLUS SUSTAIN
BALANCED MODULATOR
AND MANY MORE IN OUR
FREE CATALOG

PAIA ELECTRONICS

BOX R14359, OKLAHOMA CITY, OK 73114

Circle 19 on reader service card

SPRAY AWAY THE RACKET.



Squeak. Whine. Whirr. Pssst! Silence. Quietrol did it again. Silenced those moving T.V. parts, with one squirt from the handy spray pack. Cleaned away dirt, dust, and crud. Without damaging anything . . . in any black and white or color set. Silence is golden. So is Quietrol.

Also available in bottles, and the new Silicone—"Silitron."



Product of
QUIETROLE
COMPANY

Spartanburg, South Carolina

Circle 20 on reader service card

They put a rotary engine in a car. We put a cam shaft in a turntable.



For the same reason.

The reason? To make it quieter, smoother, more reliable.

The basic record changer mechanism—like the automobile's piston engine—has been a fairly reliable device that has served with some success for many years. But the very action of the engine—or the changer—produces constant vibration and strong, sudden movements that can ultimately wear it out.

Now we have alternatives. For cars, the Wankel rotary engine. And for record players, the sequential cam shaft drive mechanism used in BSR's finest automatic turntables.

Its even rotating motion programs the complex automatic functions of the BSR 710 and 810 smoothly and without noisy and potentially harmful quick starts and stops, without slamming metal against metal. And because the cam gears are mounted on a carefully machined central shaft, they are all but impossible to put out of alignment by rough handling or constant use.

The result: consistent care-free performance, and good music. With the BSR 710/X and 810/X Transcription Series Total Turntables.



BSR

BSR (USA) LTD.
BLAUVELT, NEW YORK 10913

Circle 21 on reader service card

NOVEMBER 1973 • RADIO-ELECTRONICS 81



**'ORDER'
PRODUCTION LINE
QUALITY
RECTIFIERS**

Item No. Item Price \$

Radio/TV Applications

- 1 6500 PRV Sel. Focus Rectifier 4/\$2.00
- 2 5 Pin Convergence Rect./Magnavox 4/\$1.00
- 3 7 Pin Convergence Rect./Wells-Gard 4/\$1.25
- 4 7 Pin Convergence Rect./Misc Makes 4/\$1.25
- 5 9 Pin Convergence Rect./RCA 4/\$1.50
- 6 Selenium Voltage Tripler 4.95 Ea
- 7 Silicon Voltage Tripler 5.50 Ea
- 8 800 PRV Sel. Boost Rect. (Zenith/Wells-Gard) 4/\$1.00
- 9 1200 PRV Sel. Boost Rect. (Wells-Gard) 4/\$1.50
- 10 Sil. 1B3 Retro-Fit Rect. 6.50 Ea
- 11 Sil. 5R4 Retro-Fit Rect. 4.75 Ea
- 12 Sil. 5U4 Retro-Fit Rect. 3.30 Ea
- 13 Sil 5V4 Retro-Fit Rect. 3.30 Ea
- 14 Sil 5Y3 Retro-Fit Rect. 3.10 Ea
- 15 Sil. 5Z4 Retro-Fit Rect. 3.30 Ea
- 16 Sil. 6X4 Retro-Fit Rect. 4.35 Ea

General/Industrial Applications

- Silicon Single Phase Bridge Rectifiers
- 17 2A, 50 PRV—BRE200.5 \$1.15 Ea
 - 18 2A, 100 PRV—BRE201 1.20 Ea
 - 19 2A, 200 PRV—BRE202 1.30 Ea
 - 20 2A, 400 PRV—BRE204 1.40 Ea
 - 21 2A, 600 PRV—BRE206 1.70 Ea
 - 22 2A, 800 PRV—BRE208 1.90 Ea
 - 23 6A, 50 PRV—BRH600.5 3.40 Ea
 - 24 6A, 100 PRV—BRH601 3.80 Ea
 - 25 6A, 200 PRV—BRH602 4.20 Ea
 - 26 6A, 400 PRV—BRH604 5.15 Ea
 - 27 6A, 600 PRV—BRH606 6.35 Ea
 - 28 6A, 800 PRV—BRH608 6.95 Ea
- Silicon H.V. 1/2 Wave Rectifiers
- 29 1A, 5000 PRV—RC5477 \$6.85 Ea
 - 30 1A, 6000 PRV—RC5478 7.65 Ea
 - 31 1A, 7000 PRV—RC5479 8.40 Ea
 - 32 1A, 8000 PRV—RC5480 9.25 Ea
 - 33 1A, 10,000 PRV—RC5481 10.20 Ea

Silicon Retro-Fit Rectifier Tubes

- 34 250R \$104.00 Ea
- 35 371 40.30 Ea
- 36 575 72.00 Ea
- 37 576 32.75 Ea
- 38 673 72.00 Ea
- 39 866 8.50 Ea
- 40 872 21.25 Ea
- 41 8008 21.25 Ea
- 42 8020 46.30 Ea

ORDERING INFORMATION

- Minimum Order—\$10.00
- Prices include shipping charges to anywhere within Continental U.S.A.
- Complete order blank with—"Item No.", Qt. of each item being ordered, & total price—Send order form & accompanying money order or check to:

RECTIFIER COMPONENTS CORPORATION
1112 LOUSONS RD. UNION, NJ 07083

NAME

ADDRESS

CITY/STATE/ZIP

ITEM NO.	QT	\$	ITEM NO.	QT	\$

TOTAL \$ AMOUNT ENCLOSED.....
(SORRY—NO CASH OR COD ORDERS, PLEASE)

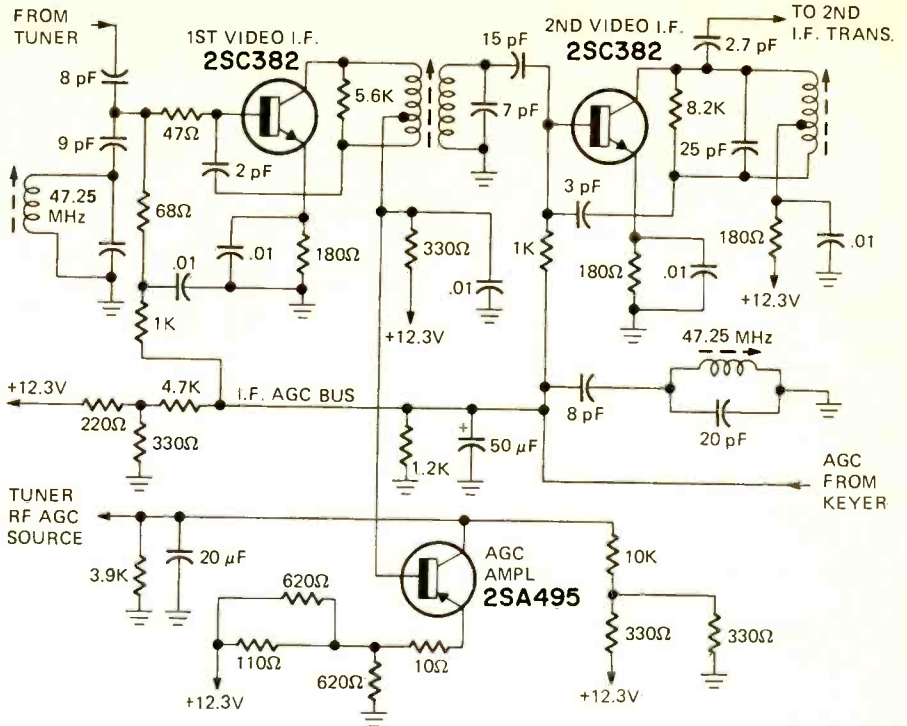

ing.—P.B., Philadelphia, Pa.

Try this: override the agc bias and see if the trouble stops. Sams Photofacts gives the normal range of agc voltage as +1.33 to 2.14 volts. If this helps, then check the agc transistor; you'll probably find that it is

leaking and causing this trouble. The emitter voltages on these two transistors will give you a good idea as to what's going on. If they go up as the set plays, the transistors are drawing more and more current, indicating a bias problem.



**AMAZING OFFER
RADIO & TV SERVICE DATA**

Here is your best, lowest-priced source for needed TV and Radio diagrams and service data. Amazing values. Only \$2.50, \$3, and \$4, per giant volume. Cover all important makes, models of all periods. Use this entire ad as your no-risk order form.

NO-RISK ORDER COUPON

TELEVISION SERVICE MANUALS

Supreme TV manuals are best for faster, easier TV repairs. Accurate factory data at bargain prices. Complete circuits, needed alignment facts, printed circuit views, waveforms, voltages, production changes, and double-page schematics. Mostly \$3 and \$4 for a large annual manual. Check volumes wanted, send entire ad as your order form.

- 1970 COLOR TV Manual, \$4. 1970 B-W TV, \$4.
- 1969 COLOR TV, \$4. 1969 B-W TV, \$4.
- 1968 TV, \$4. 1967 TV, \$4. 1966 TV, \$3.
- Additional 1965 TV, \$3. Early 1965 TV, \$3.
- 1964 TV, \$3. 1963 TV, \$3. 1962 TV, \$3.
- 1960 TV Manual, \$3. Early 1959 TV, \$3.
- 1958 TV Manual, \$3. Additional 1957 TV, \$3.
- 1955 TV, \$3. 1954 TV, \$3. 1951 TV, \$3.
- Master Index to all TV & Radio Manuals, 50¢.

RADIO DIAGRAM MANUALS

These low-priced radio manuals simplify all repairs. Cover everything you may need from recent radios to oldtimers: all type radios, stereo, combinations, transistor portables, FM-AM, and auto sets. Large schematics, all needed alignment facts, printed boards, voltage data, dial stringing, hints. Volumes are big, 8 1/2 x 11", about 190 pages each.

\$2.50

- 1966. 1965. 1964. 1963. 1962. 1961.
- 1960. 1959. 1958. 1956. 1955. 1954.
- 1953. 1952. 1951. 1950. 1948. 1946.
- 1942. 1941. 1940. **PRICE EACH, 2.50**
- 1926 - 1938 Volume of Antique Radios, \$5.

Also New 1967 - 1969 Combined Radio Volume, \$4.
 1965 Auto Radios, \$2.50. TV Service Course, \$3.

SUPREME PUBLICATIONS

1760 Balsam Road, Highland Park, ILL., 60035

Rush today TV and Radio manuals checked in no-risk order form of this ad. I am enclosing full price plus \$1 for postage and handling. Satisfaction guaranteed.

Name: _____
Address: _____
City: _____ ZIP: _____

INTERMITTENT FUSE BLOWING

I've got a Sentinel 1U-816C color TV that blows the B+ fuse at odd intervals, usually about an hour after it's turned on. I've replaced the damper tube, and checked the horizontal output, etc, but I haven't found it yet.—R.T.C., San Rafael, Calif.

There are two ways to attack this kind of problem. One is the brute-force method, which is putting a big fuse in it, turning it on and waiting to see what catches fire. This is often a very good way to do it, but you must keep a close watch, to avoid any further damage. (Like burning up a perfectly good flyback, or something nice, like that!)

Probably the easiest way is to start 'monitoring' things, to get the general area of the trouble pinned down. Set the horizontal output tube on a 'cathode-break' adapter, and note the current. Another one is to make up a pilot light socket with a plate cap on one end and a clip on the other; take off the output tube plate and put this in series. Put a 500 mA pilot light in it.

Now hook a meter on the boost voltage somewhere, and then turn it on. If the overload is somewhere in the horizontal output tube load, the pilot light will flare up when the current rises. The boost voltage may go down, or even go up, depending on

what is happening.

Another good point would be the bias or cathode-current of the high-voltage regulator tube.

Intermittent shorts or flashovers in the high-voltage regulator, high-voltage rectifier or even the focus rectifier will also do this, so you might try replacing these tubes first just to make sure.

SNOWY I.F.

In a Magnavox transistor TV, I've run into quite a few that develop excessive snow. This seems to happen within a few weeks after they have been sold. Do you have any ideas as to what could be done to help this?—A.C., Miss.

For one thing, transistor i.f.'s in many sets will have one position of the agc control that will cause snow, even on a strong signal. You might try readjusting the agc in the home, to see if this helps. Alternate; cook these sets as long as possible while they're still on the floor.

I have heard one, recently, which I pass along without comment. A field engineer for a well-known test-instrument company says that transistors will *change* in characteristics during the first few hours of use. Your experience might tend to bear this out; it would take some careful experimentation to verify it. R-E

Everything you wanted to know about CD Ignition Systems but didn't know whom to ask.

Send for **FREE Tiger booklet** (20 pages) which answers all your questions.

Name _____
Address _____
City _____
State _____ Zip _____

CLIP OUT THIS AD AND SEND TO—

TRI-STAR CORP.
P. O. Box 1727 Dept. H
Grand Junction, Colo. 81501
Circle 23 on reader service card

UNTIL RECENTLY, THERE WERE OVER 22,500 TRANSISTOR PART NUMBERS TO WORRY ABOUT IN THE SERVICE BUSINESS.

Now, only 47 types
put an end to the nightmare.

Sprague's concise but complete line of 47 replacement transistors (24 small-signal, 18 power, and 5 field effect) is designed to do the work of over 22,500 O.E.M. transistors. But don't just take our word for it. The 'Fantastic 47' are on the self-service Semiconductor Q-Mart at your Sprague distributor's, ready to help you now.



And here's more good news! To help you keep the most-frequently-used transistors handy in your shop, we've got a new KS-10 Transistor Assortment. The Keen 18 . . . 10 small-signal transistors and 8 power transistors . . . give you a working inventory that replaces thousands of the most popular domestic and foreign O.E.M. part numbers. They come in an attractive, blue, durable plastic cabinet . . . you pay for transistors *only* . . . cabinet is yours at no additional cost!

See the KS-10 with a special introductory price at your distributor's. While you're there, pick up a free copy of the 48-page Sprague K-500 Semiconductor Replacement Manual. Or . . . write to Sprague Products Co., 81 Marshall St., North Adams, Mass. 01247.

NEW KS-10 TRANSISTOR ASSORTMENT . . . REGULARLY \$34.11

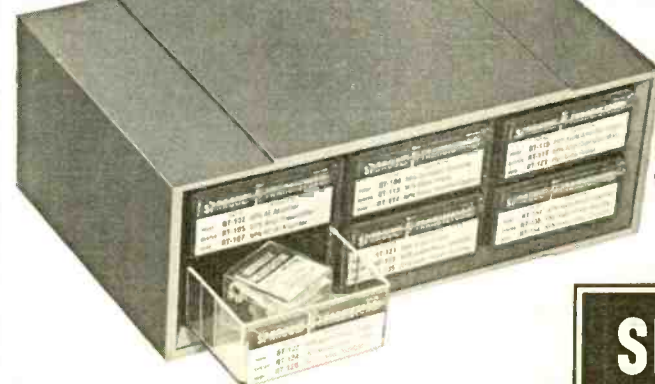

special
introductory
price . . .

\$24⁹⁹



THE BROAD-LINE PRODUCER OF ELECTRONIC PARTS
Circle 24 on reader service card

NOVEMBER 1973 • RADIO-ELECTRONICS 83

The GREATEST TV Schematic Bargain EVER Offered!

Complete TV Schematics for less than 5c each

COVERS ALL COLOR TV 1960-1968 AND
23 BRANDS B & W FROM 1965-1968

Here are FABULOUS savings on nationally-known TV schematic and service data—on everything you need to fill your vital service data needs for TV model years 1965 through 1968 . . . plus COLOR TV from 1960 through 1968! It amounts to a low, low cost of less than \$9.00 per year for your TV service data . . . with 5 more years of Color TV coverage thrown in for good measure!

SERVICE DATA FOR 23 BRANDS

TV TECH/MATICS includes complete schematic diagrams and vital servicing data for every TV receiver produced by more than 20 leading American Manufacturers for 1965, 1966, 1967, and 1968. All diagrams and servicing details are completely authentic. Each year's coverage is permanently bound into two convenient-to-use volumes which open flat to 11" x 29½", ready to provide you with instant service data at your workbench. Some diagrams as large as 58" x 22"!

HERE'S WHAT YOU GET

You receive 8 BIG volumes in all. Included is a clearly detailed and annotated TV schematic diagram for each specific model. You also get complete replacement parts lists, alignment instructions, tube and component location diagrams, plus key waveforms and voltage readings . . . all the information you need to service over 90% of the TV receivers you'll encounter!

Each volume is organized alphabetically by manufacturer, then numerically by model number. In addition, a handy Chassis/Model Finder is bound into each volume. Regular list price for each year's coverage—2 BIG volumes—is \$19.90. All 8 volumes normally sell for \$79.60. Your price is ONLY \$34.95 . . . a savings of nearly \$45.00!

MONEY-BACK GUARANTEE

Order at our risk for FREE 10-day examination. Prove to yourself they are worth many times the price.

CONTENTS

The 8 BIG volumes (2 for each year) cover all black-and-white receivers for model years 1965 through 1968—PLUS Color TV coverage from 1960 through 1968—for these brands: Admiral, Airline, Andrea, Coronado, Curtis Mathes, Dumont, Electrohome, Emerson, Firestone, General Electric, Hoffman, Magnavox, Motorola, Nuntz, Olympic, Packard-Bell, Philco, Philco-Ford, RCA Victor, Sears Silvertone, Satchell-Carlson, Sonora, Sylvania, Tru-tone, Westinghouse and Zenith.
Publisher's List Price each year \$19.90
Total \$79.60. Special price \$34.95 only while they last!

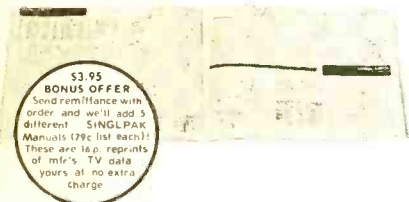

LARGE PAGES, 15x11", open flat to 29½x11".
Provides complete schematic diagrams.

NO RISK COUPON—MAIL TODAY

TAB Books, Blue Ridge Summit, Pa. 17214
 I enclose \$34.95. Please send me your complete 8-Vol. Tech/Matics Schematic Offer postage prepaid . . . plus my 5 FREE SINGLPAK Manuals.
 Please invoice me for \$34.95 plus postage. Same return privileges.

Name Phone.....
Company
Address
City State Zip.....
Foreign, add 10%. Pa. add 6% sales tax. RE-113

Circle 25 on reader service card

new products

More information on new products is available from the manufacturers of items identified by a Reader Service number. Use the Reader Service Card inside the back cover.

RECORD RACK comes knock-down; consists of two sides, multiple supporting bars and self-threading screws and is easy to assemble. Holds up to 50 albums and has sliding pressure locking rings to keep fewer than 50 albums straight and in place. Albums are tilted for easy iden-



tification.

Transparent smoke walls and crystal clear supporting bars. Also available is 8-track rack; \$8.00 each.—**Shapcraft Corp.**, 475 Park Avenue South, New York, N.Y. 10016.

Circle 31 on reader service card

LOUDSPEAKER SYSTEM, ADC-XT 10 is a two-way, three-driver system. Bookshelf size unit has 37 Hz to 20 kHz response ± 3 dB. High-frequency drivers: two 2½" viscos impregnated cone

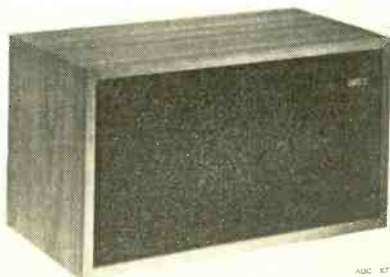

tweeters with 1¼" diameter effective radiating surface. Low-frequency driver: 10" with high-compliance suspension and high power handling construction.

Oiled walnut; air-tight cabinet. 23¾"

x 13" x 11¼"; foam grille; \$115.00.—**Audio Dynamics Corp.**, Pickett District Road, New Milford, Conn. 06776.

Circle 32 on reader service card

CIRCUIT DESIGNER gives the beginner and experienced user a design unit where op-amps, CMOS, etc., can be readily used. Features a $\pm 15V @ 50$ mA current-limited power supply as well as a $\pm 5V$ dc regulated output at 100 mA. All outputs are short-circuit protected. Has

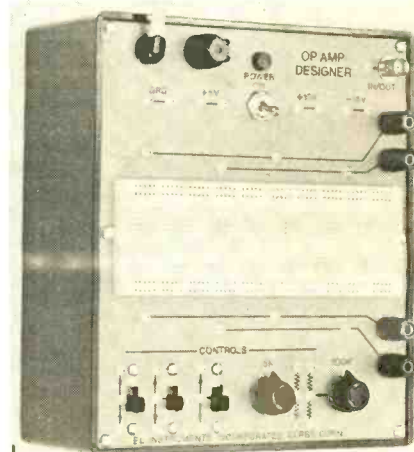

two linear rotary potentiometers (5000 and 100,000 ohms nominal resistance) and three slide switches (spdt). Kit form models from \$45.00; assembled models from \$85.00.—**E&L Instruments, Inc.**, 61 First Street, Derby, Conn. 06418.

Circle 33 on reader service card

COMPUTER CALCULATOR, HP-80. All you do is make a few entries and in seconds your problem is solved. Pre-programmed with 36 separate financial capabilities (plus the basic four functions) that include: constant storage, square root, future date given number of days, future value of an amount compounded, present value of an annuity, number of periods for a mortgage and true equivalent annual rate.

Displays up to 10 significant digits. Automatic decimal point positioning, selective round-off, indicators for improper operations and low battery condition. Solid-state electronics and LED display. Operates on ac or rechargeable batteries. 9 oz.; 5.8"L x 3.2"W x 0.7 to 1.3"H. Temperature operating range: 32°F to 104°F (0°C to 40°C). \$395.00 in-

cludes battery pack, 115/230V ac adapter/recharger, Quick Reference Guide, operating manual and safety



travel case.—Hewlett Packard, Advanced Products Division, 10900 Wolfe Road, Cupertino, Calif. 95014.

Circle 34 on reader service card

POCKET CALCULATOR, Rapidman 801 is an 8-digit calculator that performs four basic arithmetic functions, mixed or constant calculations, chain division and

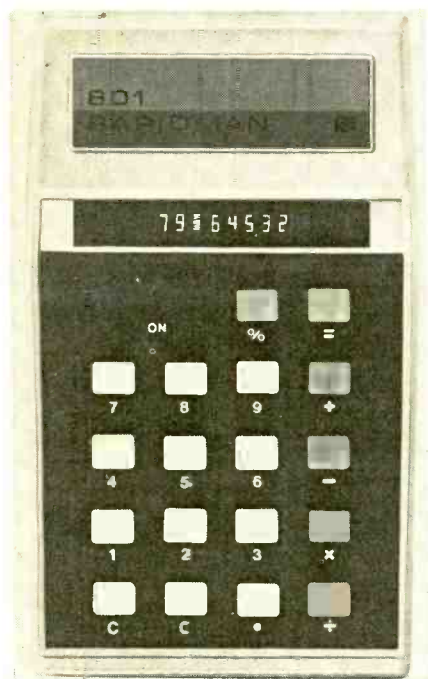

multiplication. Floating decimal point system is used in entry and answer. Indicators show negative sign and overflow entry/answer. Can obtain square or powers of a number, negative powers of numbers, reciprocals, do automatic percentage calculations, automatic percentage add-ons and discounts, etc. Supplies automatic round-off and can operate in either full floating point or adding machine mode. Single key for entry correction and clearing of calculator.

Powered by standard 9-volt disposable battery or rechargeable nickel-cadmium battery with optional recharger. Can also be ac line-operated with adaptor. Single chip, large-scale IC. 5 1/4"

x 3 3/4" x 0.9"; 8 oz.; \$119.95.—Rapid Sales Corp., 29245 Stephenson Highway, Madison Heights, Mich. 48071.

Circle 35 on reader service card

UHF PREAMPLIFIERS, SCMA-U series. Used on channels 14-70; each has its own low noise-figure rating etched directly on nameplate together with channel number. Typical noise figures are 3.5 dB for all channels from 14-50, guaranteed maximum not exceeding 4.0 dB and 4.5 dB for channels 51-70. Minimum gain is 22 dB for any of the available channels.

Mounted on single glass-epoxy PC

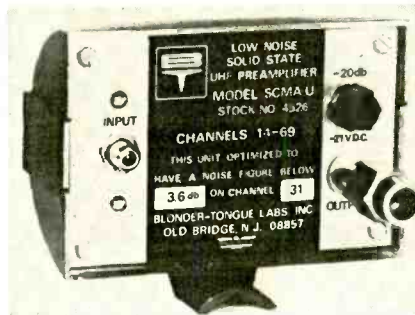

board; powered by -21 volts that can be duplexed on signal cable; 3" x 5" x 2". Equipped with type F input and output-monitoring connectors. Output-monitoring connector provides back-matched -20 dB test signal that permits performance monitoring and antenna orientation while unit is mounted on tower. CATV operator price \$139.00.—Blonder-Tongue Laboratories, Inc., One Jake Brown Road, Old Bridge, N.J. 08857.

Circle 36 on reader service card

AM & FM STEREO TUNER, AF-6 combines the FM-5 multiplex tuner features with newly designed AM circuits. Extends audio range without inhibiting selectivity to provide best possible AM reception. Two other switch-selected audio bandwidth positions provide usable re-

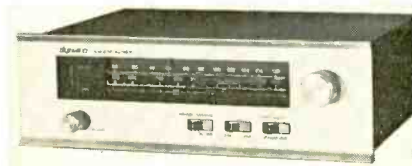

ception of less perfect signals for normal reception and for high interference conditions. Twelve-section LC design i.f. filter provides selectivity of 20 dB at 10 kHz and 55 dB at 20 kHz. Agc characteristic provides easy listening to signals from 50 to 500,000 μ V. 10 kHz notch filter reduces off channel interference. 60 dB image rejection; 70 dB i.f. rejection; less than 2% distortion. Three preassembled circuit boards and front end are completely aligned.—Dynaco, Inc., 3060 Jefferson Street, Philadelphia, Pa. 19121.

Circle 37 on reader service card

FM MODULATION METER, ECM-5 covers all bands from 30 to 50 MHz. Features peak reading meter that has a special time constant circuit that causes the needle to deflect upscale rapidly and

You'll be happy, too, with SK3020.

It replaces nearly 2,800 types and does the job as well or better. That means less service time, less inventory, more business for you. And with RCA's full SK line of only 156 devices, you'll have everything you need to replace over 51,000 foreign and domestic types.

Contact your RCA Distributor today for the full SK story and get the new RCA SK Replacement Guide, SPG-202N, too.

RCA Electronic Components
Harrison, N.J. 07029

RCA Electronic Components



downscale slowly. Deviation of any FM transmitter can be accurately adjusted between 0 and 25 kHz using voice or tone modulation. Frequency selection is



WANT TO MEET SOME OLD-TIMERS ?

Send for Vintage Radio, the 1887-1929 pictorial history of wireless and radio. 263 pages. 1000 photos.

Collectors: McMahon's 1921-1932 Radio Guide is a must! Over 50,000 facts.



ORDER NOW! Send to McMahon's Vintage Radio, Box 2045 Palos Verdes Peninsula, Calif., 90274

Vintage Radio, handbook \$4.95
 Vintage Radio, hard cover 6.95
 Radio Collector's Guide 3.95

California residents add 6% State Sales Tax.

Name _____
 Street _____
 City _____ State _____ Zip _____

IDEAL HOLIDAY GIFTS!

Circle 83 on reader service card

crystal controlled.

Built in or external antenna; all solid-state construction; battery powered; battery condition indicator. \$75.00 less batteries and crystals. Crystals \$7.10 each for all frequencies except 146.94 MHz \$3.75 each.—ECM Corp., 412 North Weinbach Avenue, Evansville, Ind. 47711.

Circle 38 on reader service card

4-CHANNEL AMPLIFIER, AA-2010 uses four conservatively-rated amplifiers that produce 260 watts into 4 ohms (4 x 65), 200 watts into 8 ohms (4 x 50), 120 watts into 16 ohms (4 x 30). All new decoder circuitry decodes all matrix encoded records currently available and handles any discrete 4-channel material at flip of mode switch. Built-in decoder enhances recorded stereo material and stereo FM by reproducing out-of-phase ambience common to 2-channel pro-



gramming.

Individual amplifier sections are controlled in pairs that provide two complete and independent stereo systems if desired. Pushbuttons activate speaker pairs in any combination up to eight speakers—or two complete 4-channel systems.

TUNE-IN

on these TOP-RATED "NO-NOISE" PRODUCTS

PROVEN PERFORMANCE FOR COLOR AND B/W

FIRST, simply spray parts with **SUPER SPRAY BATH**.

Dissolve and flush away grease, dirt, oil and oxidation—penetrative action cleans and restores all component parts.

THEN, follow with **VOLUME CONTROL AND CONTACT RESTORER**

for special attention to volume controls, push button assemblies, band switches, relays and other electrical contacts.

"NO-NOISE" products are guaranteed non-flammable, no carbon tet, non-toxic—safe for plastics.

For Tuners (incl. water type) use

TUNER TONIC With Perma Film

OR SUPER LUBE for further

cleaning and lubrication—economical, a little does a lot.

Other Famous "NO-NOISE" Products

• EC-44 • Frigid Air • Tape-Rec'd Head Cleaner

Often imitated but never duplicated

ELECTRONIC CHEMICAL CORP.

813 Communipaw Avenue Jersey City, N. J. 07304

Circle 26 on reader service card

Twenty input level controls—enough for up to five 4-channel program sources—can be adjusted beneath the chassis. \$359.95.—Heath Company, Benton Harbor, Mich. 49022.

Circle 100 on reader service card

CD-4 DISC DEMODULATOR, QD-240 reproduces discrete 4-channel sound from all CD-4 discrete records. Connect between stereo turntable and 4-channel amplifier or receiver. Demodulates the signal into four distinct channels. Sound separation is read on front panel by a large illuminated panel meter. 3-position function switch allows a choice between 2-channel, 4-channel auto or direct. 4-channel auto position provides an automatic switching function between 4-channel and 2-channel sound sources.



Signal-to-noise ratio to more than 70 dB, frequency response of 20 Hz to 15 kHz, left/right separation of 30 dB, using standard test signal of 1 kHz. Test record included to enable user to adjust for maximum separation. \$139.95.—U.S. Pioneer Electronics Corp., 178 Commerce Road, Carlstadt, N.J. 07072.

Circle 40 on reader service card

MINIATURE RESISTANCE CALCULATOR, R-1 has over 825 different values. To use as substitution box: plug one lead into 0 ohms, plug additional lead into desired value. If value desired is not shown, plug lead into the next higher range and move the 0-ohm lead to subtract the difference. As step decade: plug lead into 0 ohms and move

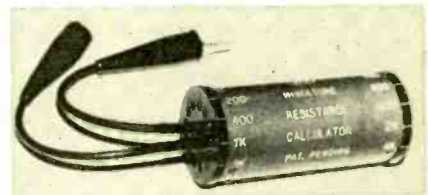

second lead. Will decade in steps of 1K, 10K, 100K, up to 11 megohms.

As automatic voltage divider: connect 0 ohms to ground and connect a high value with second lead to voltage source. Can get up to 25 different voltages at the same time from one ac or dc source. Less than 1 lb.—Lee Electronic Labs, Inc., 88 Evans Street, Watertown, Mass. 02172.

Circle 41 on reader service card

BOOSTER COUPLERS for TV reception. Designed for pegboard display.

Vhf/uht/FM model PC4382BP (one 300-ohm input—four 300-ohm outputs) \$48.15; vhf/uht/FM model PC4782BP

(one 75 or 300-ohm input—four 75-ohm outputs) \$51.30; vhf/FM model PC4312BP (one 300-ohm input—four 300-ohm outputs) \$37.65; vhf/FM model



BOOSTER-COUPLER



PC4712BP (one 300-ohm or 75-ohm input—four 75-ohm outputs) \$43.95.—JFD Electronics Corp., 1462 62nd Street, Brooklyn, N.Y. 11219.

Circle 42 on reader service card

REPLACEMENT SPEAKER, model RP6 is a Poly-Planar plastic speaker that directly replaces conventional 5 1/4" cone speakers in all applications. Wide frequency range 5 1/4" pin-cushion speaker

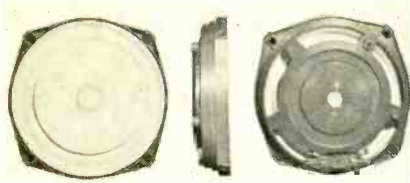

design can handle 10 watts rms power, but is only 1 1/2" deep. Response is 55 Hz to 20 KHz, 8 ohms; \$7.95.—Magitran Co., 311 East Park Street, Moonachie, N.J. 07074.

Circle 43 on reader service card

FM TRANSCEIVER, HR-2B puts out 15 watts of power on any of its 12 crystal controlled transmit channels for the 144-148 MHz spectrum. Receiver section has sensitivity rating at 0.35 μ V, 20 dB quieting and an audio output of 3 watts.



Features a noise compensated squelch system; channel 1 crystal for 146.94 MHz is factory installed.

Transmit channels are provided with individual trimmer capacitors in point-to-point or repeater applications. Built-in

VSWR bridge limiting circuitry protects against open or shorted antenna conditions. Operates on 13.8 volts dc power supply with low current drain factor. 2 1/4" x 5 1/2" x 7 1/2"; \$229.00 complete with plug-in, hand-held, high Z ceramic mike, transmit and receive crystals for channel 1 position and mobile mounting bracket.—Regency Electronics, Inc., 7900 Pendleton Pike, Indianapolis, Ind. 46226.

Circle 44 on reader service card

BIOFEEDBACK MONITOR, Stock No. 1635 enables the user to listen to and see his Alpha-Theta brainwaves. Has ultra-sensitive electrode headband that slips on or off (no creams or solutions).



Hooked to an amplifier, it filters brainwaves and signals an audible beep for each Alpha or Theta wave passed. Monitoring button simulates and identifies the Alpha sound. Both audio and visual feedback.

Fully portable; 8" x 3" x 4"; 24 oz.

FREE BURGLAR-FIRE ALARM CATALOG 400 PRODUCTS



Full line of quality systems and supplies for professional or electronic hobbyist. Prompt delivery, quantity prices.



mountain west alarm
4215 n. 16th st.
phoenix, az. 85016

Circle 27 on reader service card

You'll win new customers with SK 3122.

Because it's the fast, easy way to put premium performance in over 2,800 different sockets. And that's the best way to give better service and get more customers.

Try it and see. Contact your RCA Distributor today. Ask him, too, for the new RCA SK Replacement Guide SPG-202N. It cross-references the entire SK line of 156 devices to replace over 51,000 foreign and domestic types.

RCA Electronic Components
Harrison, N.J. 07029

RCA Electronic Components



**HERE'S REAL
VERSATILITY**

**unique
ballpoint
drives hex socket screws
from any angle**

Ever try to drive hex socket screws from an odd angle? Want an easier, faster way to drive 'em under any conditions?

HERE'S YOUR ANSWER: With unique "ball-point", you can slip these Xcelite screwdrivers into hex sockets... slick as a whistle and secure as a vise... straight-on or from any angle... to drive 'em home in a flash! 9 sizes: .050" - 3/16". With fixed handles, singly or complete set in roll up kit, and as interchangeable Series 99 blades, singly or with handle and extension in compact case.

REQUEST BULLETIN 273L

*nationwide availability
through local distributors*



XCELITE, INC.

10 Bank Street, Orchard Park, N.Y. 14127
In Canada contact Charles W. Pointon, Ltd.

Circle 28 on reader service card

**NOW WHEN YOU
THINK SMALL... THINK**

**Xcelite Mini
driver sets**



Smaller than a matchstick, Xcelite's "Mini-Screwdrivers" put product precision in your hands for fine work. Technicians, servicemen, assemblers, model-makers, hobbyists welcome these color-coded little screwdriving gems.

Instruments, apparatus, machinery, optics, cameras, watches, clocks... useful wherever screws as tiny as 0000 are involved.

Two handy kits in see-thru plastic cases: M50—five drivers for slotted screws, tips from .040" to .100". M60—same plus 00 Phillips driver and piggyback torque-amplifier handle.

REQUEST GENERAL CATALOG 171

*nationwide availability
through local
distributors*



XCELITE, INC.

10 Bank Street, Orchard Park, N.Y. 14127
In Canada contact Charles W. Pointon, Ltd.

Circle 28 on reader service card

Operates on two 9-volt batteries; \$124.50.—Edmund Scientific Co., 380 Edscorp Bldg., Barrington, N.J. 08007.

Circle 45 on reader service card

TV MARKER/SIGNALYST, WR-525A services TV receivers and CATV, MATV and closed-circuit systems. Can be used with sweep-alignment generators to check TV tuners and overall rf/i.f. receiver alignment on all vhf and many uhf channels.

Continuously tuned unit is calibrated for fundamental signal output on picture-carrier frequencies and provides dual picture and sound sweep-alignment



markers when modulated with 4.5-MHz signal. Connections for external video input make it possible to modulate the unit with dot, cross-hatch or color-bar signals from external generator or with video output from TV receiver. Can produce pattern or picture on any vhf channel. Modulated harmonic output will produce patterns or pictures on many channels within the uhf TV range. 4 1/2" x 3 1/2" x 3"; powered by single 9 volt battery or from external power supply; \$46.50.—RCA Commercial Engineering, Harrison, N.J. 07029.

Circle 46 on reader service card

TAPE SOLDER. Twist your wires together, wrap them with a piece of Tape Solder and melt it with a match, candle or cigarette lighter flame. No soldering iron needed. Ideal for on-the-spot wiring



and repairs, installing light fixtures, automotive accessories, while camping, etc. 100 pre-cut pieces 89c.—Radio Shack, 2617 West 7th Street, Fort Worth, Tex. 76107.

R-E

Circle 47 on reader service card

**Why pay
retail for hifi?**

Buy direct from us, and you save money with our high-volume prices on more than 100 name brands. Order from the branch nearest you to save time and money on freight.



**Midwest
Hifi
Wholesale
& MAIL ORDER DIVISION**

Send for our free catalog!
2455b Wisconsin Ave,
Downers Grove, Ill 60515
3309 E. J W Carpenter Frwy,
Irving, Tex 75062

Circle 29 on reader service card

FREE catalog



**over
1000
unique tools,
handy kits,
precision
instruments,
technical
supplies.**

Our 21st year of service to the World's finest craftsmen and technicians.

National Camera
2000 West Union Ave. Dept. GBB
Englewood, Colorado, 80110

Send a FREE copy of the nc Flasher

name _____
address _____
city _____
state _____ zip _____

National Camera
2000 West Union Ave. Dept. GBB
Englewood, Colorado, 80110

Circle 30 on reader service card

new lit

All booklets, catalogs, charts, data sheets and other literature listed here with a Reader Service number are free. Use the Reader Service Card inside the back cover.

ASSEMBLY-DISASSEMBLY HANDBOOK. 36-pages of up-to-date operational procedures for asolder extraction, coating removal and component lead forming techniques for sensitive and expensive electronic assemblies and components. Each technique is explained and illustrated.

Features fully illustrated and easy-to-understand descriptions of the advanced PACE-developed products and systems that are used to apply these techniques. Complete with glossary of technical terms.—Pace, Inc., 9329 Fraser Ave., Silver Spring, Md. 20910.

Circle 48 on reader service card

RADIO & TV TUBES CATALOG. 48-page catalog contains individually-priced tubes, tube and continuity checker, antennas, battery charger as well as cutting pliers, stereo headphones, pool alarm kit, electronic cleaner and car equipment (gas siphon pump, emergency starting cables and trunk lid ties). Also contains soldering gun and iron, desoldering bulb and electric pencil engraver.—Cornell Electronics Co., 4217 University Avenue, San Diego, Calif. 92105.

Circle 49 on reader service card

EXPANDING THE ART OF TAPE RECORDING is a 24-page booklet that describes how various accessories or extensions to a tape recorder are engineered. Features: microphone and impedance converters, service accessories, special-effects accessories, pause/repeat control accessories, timer controls, remote controls, reels and reel adapters as well as trouble-shooting chart.—Teac Corp. of America, 7733 Telegraph Road, Montebello, Calif. 90640.

Circle 50 on reader service card

TV TEST EQUIPMENT & ACCESSORIES CATALOG, 1973-1 is a 15-page catalog that contains test rig, transverter, CRT tester, cross-reference yoke and convergence adapters, black & white brighteners, color brighteners, service accessories, service extensions, replacement CRT sockets and leads and service kits. Many illustrations.—TeleMatic, 2245 Pitkin Avenue, Brooklyn, N.Y. 11207.

Circle 51 on reader service card

1974 ELECTRONICS CATALOG NO. 740. 244-page catalog features: antennas, alarms, auto radios, speakers & tape players, hi-fi amplifiers, 4-channel equipment, power supplies, power tools, marine equipment kits, table & portable radios, security equipment, speakers & speaker systems, switches, tape recorders, decks, players, cartridge, cassette & reel-to-reel, telephones & accessories, tools, hardware, closed circuit TV, TV sets, wire & cable, watches and walkie-talkies. Contains many illustrations and prices.—Olson Electronics, 260 South Forge Street, Akron, Ohio 44327. R-E

Circle 52 on reader service card

Untested TO-5 transistors. All with full leads. Some NPN some PNP some Silicon some Germanium. Spot check shows about 60% good units. 100 for \$3.75 ppd.

6.3 Volt 1 Amp Transformer. Fully Shielded \$1.60 Each ppd.

Transformer — 115 Volt Primary — 12 Volt 1.2 Amp Secondary \$2.45 ppd.

113 VOLT TRANSFORMER
32-0-32 Volts At 1 Amp Secondary. Also Low Current 6.3 Volts Secondary For Pilot Lights. \$2.50 Each ppd.

TRANSFORMER. 115 volt primary, 12 volt 1/2 amp secondary. \$1.50 ppd.

Transformer — American Made — Fully shielded. 115 V Primary. Sec. — 24-0-24 @ 1 amp with tap at 6.3 volt for pilot light. Price — A low \$2.90 each ppd.

Transformer, 115 VAC Primary, 12 Volt, 4 Amp Secondary \$4.00 Each ppd.

250,000 American made disc ceramics. Almost all have full leads. All clearly marked with values. A bargain we may not repeat.
100 Assorted \$2.00 ppd.
500 Assorted \$7.50 ppd.
1000 Assorted \$10.50 ppd.

Assorted untested diodes. All new with full leads. Spot check shows about 75% good useable units. Many, many Zeners, some 400 mw, some 1 Watt, some 3 Watt. Also power diodes. Put those testers to work and save dollars. About 1200-1400 pieces per pound. PRICE is a low — \$6.00 for half pound ppd. or \$10.00 for a full pound ppd.

Factory New Full leads. Fairchild RTL IC's. uL 900, uL 914, uL 923. YOUR CHOICE 3 for \$1.00 ppd.

SEND STAMP FOR BARGAIN LIST
Pa. Residents add 6% State sales tax
ALL ITEMS PPD. USA

m. weinschenker
K 3DPJ BOX 353 · IRWIN, PA. 15642

NOW! YOUR OWN BUSINESS IN THE EXCITING ALARM SECURITY FIELD



LEARN AT HOME WITHOUT RISK!

No question. The most rapidly expanding industry is home and business security. Every area, city or rural, desperately needs alarm installation and servicing companies. Right now, you can learn all the techniques of installation, of estimating, of running a profitable business at home with approved training. You receive all necessary tools, work on actual industry-type projects and receive enough equipment to do your first job, the profit from which can pay for training, launch your business. FREE INFORMATION — no salesmen.



SECURITY SYSTEMS MANAGEMENT SCHOOL

Div. of Technical Home Study Schools
Dept. 7479-113, Little Falls, NJ 07424.

RUSH ME INFORMATION on opportunities for an alarm business. No salesman is to call.

Name _____
Address _____
City _____ State/Zip _____
 Check here if Veteran

Circle 61 on reader service card

Now...the most enjoyable do-it-yourself project of your life—a Schober Electronic Organ!

You'll never reap greater reward, more fun and proud accomplishment, more benefit for the whole family, than by assembling your own Schober Electronic Organ.

You need no knowledge of electronics, woodwork or music. Schober's complete kits and crystal-clear instructions show you — whoever you are, whatever your skill (or lack of it) — how to turn the hundreds of quality parts into one of the world's most beautiful, most musical organs, worth up to twice the cost of the kit.

Five superb models with kit prices from \$500 to around \$2,000, each an authentic musical instrument actually superior to most you see in stores, easy for any musically minded adult to learn to play, yet completely satisfying for the accomplished professional. And there are accessories you can add any time after your organ is finished — lifelike big auditorium reverberation, automatic rhythm, presets, chimes, and more.

Join the thousands of Schober Organ builders-owners who live in every state of the Union. Often starting without technical or music skills, they have the time of their lives — first assembling, then learning to play the modern King of Instruments through our superlative instructions and playing courses.

Get the full story FREE by mailing the coupon TODAY for the big Schober color catalog, with all the fascinating details!

The Schober Organ Corp., Dept. RE-120
43 West 61st Street, New York, N.Y. 10023

Please send me Schober Organ Catalog.
 Enclosed please find \$1.00 for 12-inch L.P. record of Schober Organ music.

NAME _____
ADDRESS _____
CITY _____ STATE _____ ZIP _____

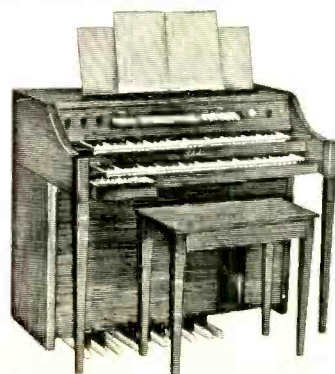

Circle 62 on reader service card

MOW

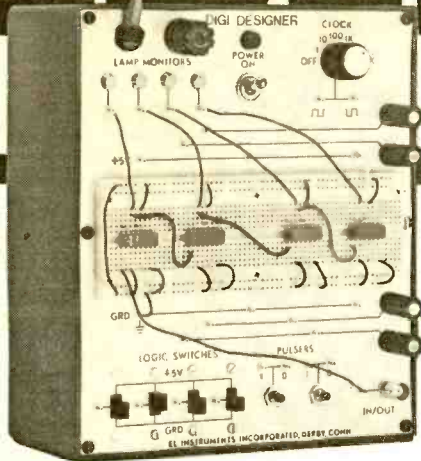

... BUILD YOUR OWN CIRCUIT DESIGNER, WITH ALL THE OUTSTANDING FEATURES OF EXPENSIVE MODELS . . . AT A LOW BUDGET PRICE.

THE DIGI DESIGNER

This compact package contains a regulated 5VDC supply, selectable frequency clock, E&L-socket, dual bounce-free pushbuttons (pulsers), 4 slide switches for voltage/ground, plus 4 independent "logic lights" for on/off states of various logic circuitry. Exclusive Breadboarding Pins offer input/output connections to socket, eliminating all soldering. All your circuit components are reuseable. Use any #22 gage solid wire. Send check or M.O. today for your choice of two models

DD1-K, Kit Form (incl. p.c. boards, all components, instruction manual) **\$59.95**

DD1-A, Assembled, ready for use **\$95.00**

- Add \$1 postage, handling
- 25% deposit on C.O.D.'s

Ask for FREE IDEA-PACKED, ILLUSTRATED CIRCUIT DESIGN CATALOG.



E&I INSTRUMENTS, INCORPORATED
61 First St., Derby, Conn. 06418
Telephone: 203/735-8774

4-CHANNEL QS MATRIX (continued from page 41)

separation is a bit over 10 dB in terms of L_r heard in the remaining three speakers.

Finally, as the 3-kHz L_b signal increases further in level, separation of the L_r signal decreases to minimum values (as heard in the L_b and R_b channels) and remains over 10 dB as heard in the R_r channel. Of course, at this time the separation of the 3-kHz L_b signal increases to over 20 dB with respect to its related and unwanted channels, but that would be shown on another similar graph in which L_b separation is referenced.

One important point made by Sansui is describing this system and its virtues, is the fact that even relatively low-level signals retain their total energy output in this process, rather than being attenuated as they are in some gain-controlled logic systems.

Multiple usage

The variable gain control required in the Variomatrix system is provided by a regular matrix and the FET circuit shown in Fig. 8. The output signal of transistor Q1 which is controlled by changing the effective emitter resistance (the FET impedance is across R_e) is matrixed with the other composite signal ($L_r + R_r$) or ($L_r - R_r$) to control inter-channel separation. Gain of the FET as a function of gate-source voltage (V_{gs}) is shown in Fig. 9.

In addition to bias changes caused by the output of the phase discriminator of Fig. 5, it is possible to have a fixed amount of bias applied to the FET to provide for different matrix settings, such as those offered on Sansui's own decoders and late-model receivers. These products have QS settings, Concert Hall settings (which provide primarily ambience effects for the listener), Phase Matrix settings (which approximate CBS-SQ decoding) and QS Synthesizer settings (intended primarily for enhancing stereo records to give a four channel effect). When the mode switch is set to the straight QS position, the FET bias is set as V_p so that the variable matrix operates only in the opening (higher gain) direction. For the Concert-Hall mode, it is set near point "b" for the front channel matrix only. The front channel matrix is "closed" only if the rear signal is stronger than the front signal. For the "Phase Matrix" mode, bias is set near point "a", so that both the front and rear decoding matrixes operate only in the *closing* direction and for the QS Synthesizer mode, bias is set near V_p or point "a".

The front-back Variomatrix principle discussed here can be further augmented by additional circuits, similar to those shown in the block diagram of Fig. 5, which operate to sense phase relationships between left and right domi-

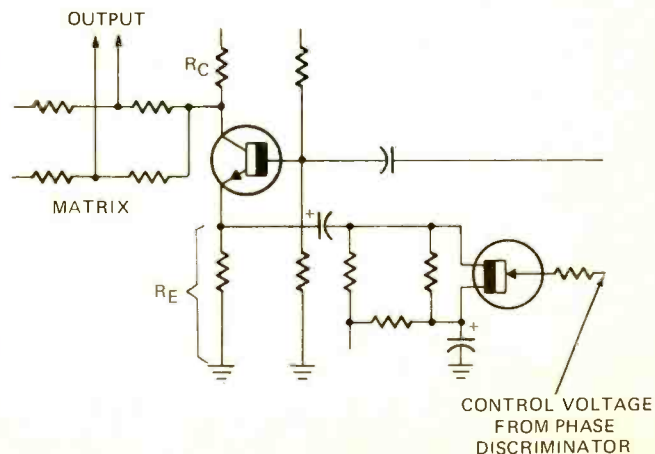
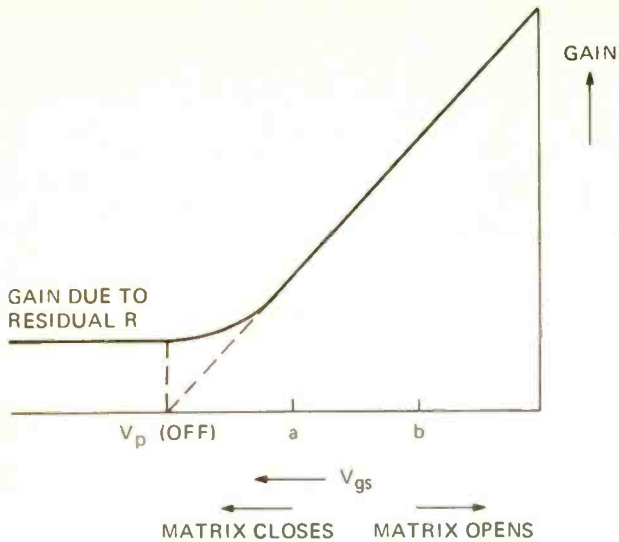

FIG. 8—FET USED AS A VARIABLE GAIN CONTROL following a matrix network for Variomatrix action.



POINT A: POINT WHERE L AND R ARE CLEARLY SEPARATED.

POINT B: POINT WHERE THE BLEND INSIDE THE ENCODER ($\Delta = 0.414$) IS ALSO CANCELLED AND L_f AND R_f ARE SEPARATED BY APPROXIMATELY 10dB.

FIG. 9—FET BIAS CHARACTERISTIC used to set mode selection points.

nance, providing two orders of control and further improvement of instantaneous separation capabilities in all four channels. With this additional refinement, Sansui claims maximum inter-channel separation of 20 dB or more for all channels.

Another refinement involves the division of matrix parameters into two frequency bands—high and low. In the left-right variable matrix portion of the new decoder circuits, low frequency matrix coefficients remain fixed while high-frequencies are acted upon by the varying coefficients. In the front-back sensing circuitry, high-frequencies are treated with fixed coefficients while low frequencies are subjected to variable coefficients. Sansui has found that this technique helps to overcome such secondary problems as "floating surface noise" and unstable localization of high-frequency instruments.

How does it sound?

I have had an opportunity to hear Sansui's latest Variomatrix decoders on more than one occasion and can testify that with properly encoded material I was hard pressed to tell the difference between matrix reproduction and the original discrete tapes from which the recordings were made. The engineering effort expended by Sansui on their QS system and its refinement has been prodigious. In terms of bandwidth utilization, Sansui has certainly shown that it is possible to convey much more "information" in two channels than would have been thought possible a few years ago.

R-E



Just don't know what we'd do without you TV technicians. By the way, I've got a set in my camper that's been acting funny, and . . .

GIANT Wall Chart of Electronic Symbols

FREE!

ELECTRONIC SYMBOLS DATA CHART — CALECTRO HANDBOOK

with every CALECTRO HANDBOOK! Available from your CALECTRO distributor!

GC ELECTRONICS
DIVISION OF HYDROMETALS, INC.
ROCKFORD, ILLINOIS 61101 U.S.A.

Free! 1973 Eico Catalog

OVER 200 INSTRUMENTS • KIT & WIRED!

NEW! TR-410 Solid State Triggered Sweep Scope
 NEW! 300C "Clamp-On" Current Tester
 NEW! TD-8 8 Track Stereo Tape Deck
 NEW! SS-200 "Time Delay" Burglar Alarm System
 NEW! ASA-300 Electronic Siren Auto Alarm

Build all-professional Eico Kits and save up to 50%. The more you know about electronics, the more you'll appreciate Eico. Over 2500 local Eico dealers offer you all the top brands, personal technical counsel, fast off-the-shelf service. Free catalog includes Test Equipment, Stereo, Eico-craft Projects, Burglar/Fire Alarm Systems and name of nearest Eico distributor, check reader service card or send 25¢ for first class mail service.

EICO, 283 Malta St., Brooklyn, N.Y. 11207
 Leadership in creative electronics since 1945



Circle 65 on reader service card

Accuracy like a VTVM... Convenience like a VOM...

NEW BATTERY-OPERATED FET
 SOLID-STATE VOLT-OHMMETER #116

Easy-to-build KIT

\$32.40 =116K

Factory-Wired & Tested

\$44.90 =116W



Now you can get all the benefits of a VTVM (laboratory accuracy, stability and wide range) but with its drawbacks gone: no plugging into an AC outlet, no waiting for warm-up, no bulkiness. New Field Effect Transistor (FET) design makes possible low loading, instant-on battery-operation and small size. Excellent for both bench and field work.

Compare these valuable features:

- High impedance low loading: 11 meg-ohms input on DC, 1 megohm on AC
- 500-times more sensitive than a standard 20,000 ohms-per-volt VOM
- Wide-range versatility: 4 P-P AC voltage ranges: 0-3.3, 33, 330, 1200V; 4 RMS AC voltage ranges: 0-1.2, 12, 120, 1200V; 4 DC voltage ranges: 0-1.2, 12, 120, 1200V; 4 Resistance ranges: 0-1K, 0-100K, 0-10 meg., 0-1000 meg.; 4DB ranges: -24 to +56DB.

Sensitive easy-to-read 4 1/2" 200 micro-amp meter. Zero center position available. Comprises FET transistor, 4 silicon transistors, 2 diodes. Meter and transistors protected against burnout. Etched panel for durability. High-impact bakelite case with handle useable as instrument stand. Kit has simplified step-by-step assembly instructions. Both kit and factory-wired versions shipped complete with batteries and test leads. 5 1/4" H x 6 3/4" W x 2 7/8" D. 3 lbs.

Send FREE catalog of complete EMC line and name of nearest distributor.

RE-11

Name _____
 Address _____
 City _____
 State _____ Zip _____

EMC

ELECTRONIC MEASUREMENTS CORP.
 625 Broadway, New York, N.Y. 10012

next month

DECEMBER 1973

■ New Color TV Circuits

The winds of change are ever blowing through the labs of the TV circuit designer. Here's a onceover of the new circuits appearing in the 1974 color sets.

■ Remote Control For Color TV

Boy has remote control changed! See how the new ones work.

■ Slotted Mask Picture Tubes

Jack Darr tells how these new masks in combination with in-line guns improve the performance of color picture tubes.

■ COSMOS—Why Is It So Good?

All about this new kind of low-power IC. Learn how it manages to operate on microwatts of power.

■ New Approaches To Speaker Systems

Len Feldman explores the principles behind the British Industries Venturi and the Electro-Voice Interface. You'll be fascinated by the story of how these speaker systems work.

PLUS

Appliance Clinic
Replacement Transistor Guide
Build An Envelope Follower
11-Ways To Use Your Vectorscope

Circle 66 on reader service card ➤

books

SECURITY & YOU published by Hydrometral, Inc., Rockford, Ill. 61101. 8 1/4 x 5 1/4 in. 112 pp. Softcover, \$1.00.

This easy-to-understand book tells all you need to know about protecting your home, office or car against would-be intruders. It explains complete home and business protective systems plus valuable information on locks, lights and other deterrent devices along with the fascinating history of security through the years.

BUILD YOUR OWN HOME & CAR SECURITY published by Motorola HEP Semiconductors, Phoenix, Arizona. 8 1/4 x 5 1/4 in. 106 pp. Softcover, \$1.25.

This book presents unique and useful projects for the hobbyist and experimenter. These projects have been individually designed, constructed and tested by professional alarm system engineers. Each project is prepared and described in a manner that allows a fairly inexperienced person to construct a worthwhile unit with ease and at the same time, gain some basic knowledge of alarm electronics. Ten different construction projects are included, ranging from a moisture sensor alarm to a photoelectric alarm to a door/window alarm to a voltage sensing car alarm to a high-power electronic siren. Two additional chapters present a basic introduction to alarm theory and necessary construction hints and descriptions of the types of components used to build the projects in this article.

INTRODUCTION TO THE UNIFIED THEORY OF ELECTROMAGNETIC MACHINES by M.G. Say. Harper & Row, Inc., 10 East 53rd Street, New York, N.Y. 10022. 5 1/4 x 8 1/2 in. 198 pp. \$8.00.

This book regards all electromagnetic conversion devices—limited, motion as well as rotary—as variants on the common theme of gap energy. Simple general principles for the development of force and torque then lead to a variety of ways of realizing the devices. This approach uses the system concept with its accent on dynamic rather than on steady-state conditions. The book shows how the physical principles lead readily to the circuit concept upon which advanced works rely in their treatment of generalized theory. Many solved examples are presented.

EASI-GUIDE TO HI-FI STEREO by Forest H. Belt. Howard W. Sams & Co., Inc., 4300 West 62nd Street, Indianapolis, Ind. 46268. 5 1/4 x 8 1/4 in. 160 pp. Softcover, \$3.50.

Gives the hi-fi novice a broad outline of the variety, quality and expense of basic musical sound equipment and associated music sources. Aids in planning the home music system arrangement and offers directions in the search for the right equipment. Chapters included are: what a music system is, various components of a music system, factors to be considered in the listening area, language of hi-fi, equipment selection, antennas, installation, adjustment, trouble-shooting and 4-channel sound.

HI-FI PROJECTS FOR THE HOBBYIST by Leonard Feldman. Howard W. Sams & Co., Inc., 4300 West 62nd Street, Indianapolis, Ind. 46268. 5 1/4 x 8 1/4 in. 144 pp. Softcover, \$3.95.

Complete information is given about tools, techniques and materials used in each project. Detailed instructions are given on how to design a printed circuit, how to etch the boards and how to mount the components. Each chapter contains background information about the nature of the project—how it works, why it is needed and how it is used. Projects include: phono preamp, loudness control, multiple speaker switching, four-channel adapter, small speaker enclosure, and IC FM stereo adapter.

INSTALLING & SERVICING ELECTRONIC PROTECTIVE SYSTEMS (Tab Book No. 605) by Harvey Swearer. Tab Books, Monterey & Pinola Sts., Blue Ridge Summit, Pa. 17214. 5 1/2 x 8 1/2 in. 256 pp. Hardbound, \$7.95; softcover, \$4.95.

This up-to-date handbook explains how to select the right system for any particular job, how to estimate costs, how to install and check the system and even how to build and expand one's business, train help and finance the operation. Text discusses all the basic systems and then starting with sensing and detecting methods, proceeds with individual chapters on the various types of alarm systems—electromechanical, photoelectric, ultrasonic, microwave, proximity, audio and visual, seismic, vibration and stress intrusion and specialized systems such as night viewing devices, vehicular alarms, etc. Appendix carries the complete Federal Crime Insurance regulations and provides glossary and complete list of manufacturers and suppliers. Over 160 illustrations. **R-E**

MOVE AHEAD from Technician to ENGINEER

Advance beyond the technician level Become an electronics engineer

Your technical experience can be a valuable asset in advancing your electronics career to the *engineering* level. By adding engineering training and a college degree to your experience, you can *move up* to greater opportunities.

After three years of reduced demand, electronics engineering is now beginning to BOOM! It is predicted that there will be twice as many engineering jobs available by 1976 as there will be graduates to fill them.

Grantham School of Engineering is a college-level institution, specializing in teaching electronics, computer science, and supporting subjects, mainly

BY CORRESPONDENCE

You may earn your A. S. E. T. degree by correspondence, and then earn your B. S. E. E. degree thru additional training in residence.



Grantham School of Engineering

1505 N. Western Ave.

Hollywood, Calif. 90027

Mail the coupon below for our free Bulletin

Grantham School of Engineering

RE-11-73

1505 N. Western Ave., Hollywood, Calif. 90027

Please mail me your free Bulletin, which explains how the Grantham educational program can prepare me for my Degree in Electronics Engineering.

Name _____

Address _____

City _____ State _____ Zip _____

I have been in electronics for _____ years.

Circle 67 on reader service card



THIS XMAS DAY GET A GIFT YOU CAN REALLY USE.

New UNGAR All-Purpose Soldering Kit #7070

A Pro Kit Designed for Hobbyists
You get an economical yet, complete soldering kit, with 3 thread-on tips... ideal for most all electronic kit assembly and medium duty repairwork. But that's just the beginning.

Versatility; A Modular System
Only Ungar gives you this *Maximized Versatility*: Tips—heater units—even handles are interchangeable and available in an optimum variety of configurations. "Custom-make" your iron: for PC work just add a #537 heater to your kit. Tackle virtually every soldering job by simply changing components—not the whole tool. (Our brand new catalog #513 has all the details plus handy application selector... at your local electronic retailer).

Rugged, Durable Quality Too
You get a perfectly balanced handle of hi-strength plastic, comfort-cork grip, stainless steel heat deflector and flexible 2 wire, integral cord—all UL listed and backed by Ungar's guarantee of excellence.

Get the Finest Tool Available!
Maximum versatility, high quality, low cost plus a complete selection of accessories and production aids... it's the reason more pros in service, repair, R&D and on-line production demand Ungar every time. Your kit is at your local electronic retailer, right now, for only about \$6... all accessories and our new catalog are there too. **MERRY CHRISTMAS**



Division of Eldon Industries, Inc.
233 East Manville, Compton, California 90220 (213) 774-5950



Argyle socks and wild ties you may still get. This hint coupon may help. Let us know where you put it and what the results were. Ungar

technotes

BLOOMING PICTURE

When either Y155 or Y156 diode fails in the General Electric N-2 chassis, add a 680-ohm, ½-watt 10% resistor in series with the anode side of Y156 as shown in the dia-

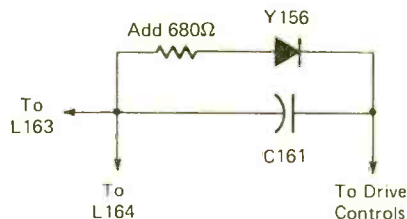

gram. Splice the resistor into the anode side of Y156 and insert the assembly into the circuit board where Y156 was removed. This will cure the problem which is basically due to internal arcing in the picture tube.—*G-E Service Talk*

MAGNAVOX SPEAKERS—FUSIBLE RESISTORS

Speaker systems such as the models 1S8757 through 1S8759 and 1S8762 through 1S8766 have a fusible resistor in series with the positive lead to the speakers. It protects against excessive current flow in the event of a shorted speaker voice coil. This fusible resistor is rated 0.225 ohm, 2 watts and is part No. 240104-3.

Because of the protective characteristics of this device, use only the exact replacement. Use the full length of the resistor leads and heatsink the leads while soldering them in place.—*Magnavox Service News Letter*

VERTICAL BUZZ, G-E SF CHASSIS

The buzz comes from laminations in the vertical output transformer. Heat from resistor R404 can soften the transformer wax. This allows the laminations to vibrate, causing the buzz.

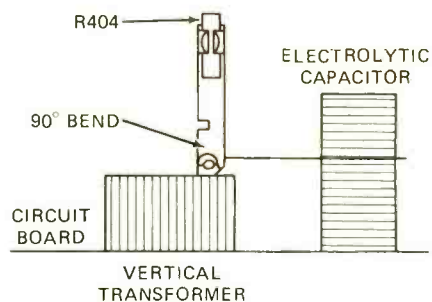

To remedy the problem, remove R404 from its bracket. Remove one screw and disassemble the bracket from the transformer and electrolytic capacitor. Bend bracket 90 degrees as shown in the drawing. Reassemble the bracket and R404. Allow the transformer to cool about one hour before applying power. This will allow the wax to harden.

Caution: In SF1600 series receivers, slide R404 down in the clip so there is at least ½ inch between R404 and the bottom cover of the vhf tuner. In SF2200 series receivers, maintain at least 1 inch space between R404 and the antenna terminal.—*G-E Television Service Bulletin* **R-E**

try this

CABLE JACKET REMOVER

There are many occasions when it is necessary to remove the outer vinyl plastic covering from a multi-con-

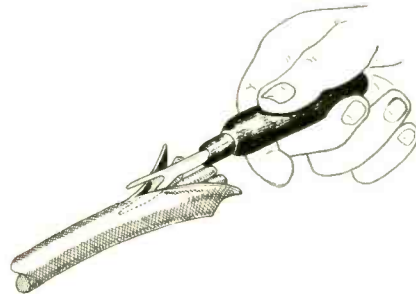

ductor cable. A fast and easy way of doing this with no risk of damaging the insulation of the conductors is to use a dressmaker's seam ripper, as shown. Simply slip the end of the seam ripper under the outer covering, and push. Zip! It slices the jacket like a knife through soft butter.—
Hugh Gordon

R-E

DID YOU MISS IT?

The Sansui Variomatrix system for producing 4-channel sound from encoded 4-channel records is presented on page 35. If you're not up-to-date on the latest developments in 4-channel sound you'll want to be sure to read this article.

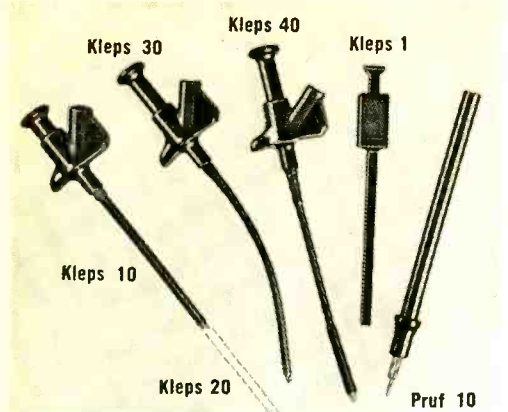

Clever Kleps

Test probes designed by your needs — Push to seize, push to release (all Kleps spring loaded).

Kleps 10. Boathook clamp grips wires, lugs, terminals. Accepts banana plug or bare wire lead. 4¾" long. **\$1.39**

Kleps 20. Same, but 7" long. **\$1.49**

Kleps 30. Completely flexible. Forked-tongue gripper. Accepts banana plug or bare lead. 6" long. **\$1.79**

Kleps 40. Completely flexible. 3-segment automatic collet firmly grips wire ends, PC-board terminals, connector pins. Accepts banana plug or plain wire. 6¼" long. **\$2.59**

Kleps 1. Economy Kleps for light line work (not lab quality). Meshing claws. 4½" long. **\$.99**

Pruf 10. Versatile test prod. Solder connection. Molded phenolic. Doubles as scribing tool. "Bunch" pin fits banana jack. Phone tip. 5½" long. **\$.89**

All in red or black - specify. (Add 50¢ postage and handling).

Write for complete catalog of - test probes, plugs, sockets, connectors, earphones, headsets, miniature components.

Available through your local distributor, or write to:

RYE INDUSTRIES INC.

128 Spencer Place, Mamaroneck, N.Y. 10543

In Canada: Rye Industries (Canada) Ltd.

Circle 70 on reader service card



Available through your local distributor, or write to:
RYE INDUSTRIES INC.
128 Spencer Place, Mamaroneck, N.Y. 10543
In Canada: Rye Industries (Canada) Ltd.
Circle 70 on reader service card



DOTHATCH®

an exclusive Lectrotech development

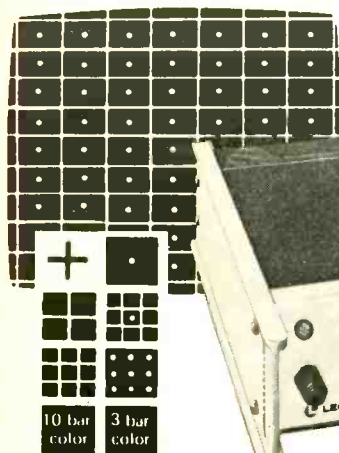

one new pattern for all coverage adjustments



BG-20 DOTHATCH COLOR GENERATOR

The ultimate in pattern stability, at all temperatures, provided by Digital IC Counters. No internal adjustments. RF output channel 3 or 4. Video output 3v. P-P. 4.5 MHz crystal sound carrier. With shoulder strap and self-contained cable compartment. Net **129.50**



See your distributor or write Dept. RE-4

LECTROTECH, INC.

5810 N. Western Ave., Chicago, Illinois 60659 · (312) 769-6262

Circle 71 on reader service card

FOR TIGHT SPOTS!



CHAPMAN

Midget RATCHET SET plus ADAPTERS

18° Working Arc

POST PAID



Seventeen different interchangeable adapters with a screwdriver attachment and extension, plus the world's mightiest MIDGET RATCHET in a compact 4" x 6" steel case. The strength of this twenty tooth stainless steel ratchet far exceeds torque standards set by military specifications. Requiring only an 18° working arc, reverse action is obtained by simply turning the ratchet over. Kit includes 12 Allen Hex Adapters from .050" to ¾", 2 popular Phillips sizes (#1 and #2), 2 Slotted Head sizes (¼" and ¾"), plus a ¼" Square Drive for use with standard sockets.

Only **\$12.95**

Send Check or Money Order



POCKET SIZE NO. 6320 KIT

THE CHAPMAN MANUFACTURING COMPANY

Send Check or Money Order to . . . DURHAM, CONNECTICUT 06422 Dept. RE-11

Circle 72 on reader service card

ELECTRONIC TECHNICIANS!

Raise your professional standing
and prepare for promotion! Win
your diploma in

ENGINEERING MATHEMATICS

from the Indiana Home
Study Institute

We are proud to announce two great
new courses in Engineering Mathematics
for the electronic industry.

These unusual courses are the result of
many years of study and thought by the
President of Indiana Home Study, who
has personally lectured in the classroom
to thousands of men, from all walks of
life, on mathematics, and electrical and
electronic engineering.

You will have to see the lessons to ap-
preciate them!

NOW you can master engineering
mathematics and actually enjoy doing it!

WE ARE THIS SURE: you sign no
contracts—you order your lessons on a
money-back guarantee.

In plain language, if you aren't satis-
fied you don't pay, and there are no
strings attached.

Write today for more information and
your outline of courses.

You have nothing to lose, and every-
thing to gain!

The INDIANA HOME STUDY INSTITUTE

Dept. RE-11, P.O. Box 1189, Panama City, Fla. 32401

Circle 73 on reader service card

DISCOUNT PRICES TEST EQUIPMENT

B&K

**SENCORE
Leader**

I.C.C./Mullard
Tube Specials

Telematic Test Jigs
& Accessories

Catalog & Prices on Request

FORDHAM Radio Supply
Company, Inc.



558 Morris Ave.
Bronx, N.Y.
Tel: (212) 585-0330

RCA

DISTRIBUTORS OF ELECTRONIC SUPPLIES

Circle 74 on reader service card

EQUIPMENT REPORT

(continued from page 61)

curve tracer and a working service-
type oscilloscope.

The scope does not have to be a
highly accurate type. The *Model A* has
built-in calibrating features. The stair-
case output of the curve tracer is fed
to the vertical input, and the vertical
gain control set so that each step cov-
ers one division of the graticule. The
scope is now set at 1.0 volt per divi-
sion. If the scope has a X1/X10, etc.
attenuator, this is handy. Calibrated at
1.0 V/div, then turned to the X10 for
0.1 V/div, the screen will then read
1.0 mA per division, of the transistor's
collector current.

Horizontal sweep is calibrated by
reading the setting of the SWEEP VOLT-
AGE dial. You can adjust this for any
desired V/div setting. At 10 volts
sweep, for example, set for 5 or 10 di-
visions, and so on.

With this instrument you can not
only tell whether a transistor is good
or not, but identify its polarity, pnp or
nnp; and its material, silicon or ger-
manium, by a quick twitch of a
switch. Just set the controls to the
point where you see a family of
curves and read the dials. An open
transistor makes a horizontal line; a
shorted transistor makes a vertical
line. Instant identification.

Dual TO-5 transistor sockets are
provided on the top of the case. By
flipping the socket selector switch back
and forth, you can accurately match
any pair of transistors. If the patterns
are the same, these two are matched.
A third position on this switch selects
the probes. These plug into a socket
on the front panel.

One of these has three very sharp
pins, for in-circuit tests. If you can't
get to a transistor with this, another
one has three tiny alligator clips. This
last one is also very handy for hook-
ing up transistors with odd basing,
larger types such as the TO-3 and TO-
66 case, and anything that won't fit
the sockets.

This instrument will not damage
transistors under test. Current limiting
resistors prevent this, even during the
very useful collector-current break-
down test. If the transistor is inserted
in the socket incorrectly, the character-
istic upside-down L pattern will tell
you. The instruction manual gives a
fast method for locating the correct
connections to unknown transistor
types, a very useful thing. Needless to
say, while checking out this in-
strument, I managed to make all of
the hook-it-up-wrong tests, some of
them intentionally, and I came out
very well.

In-circuit curve-tracer tests are be-
(turn page)

PRE-CHRISTMAS SALE

COLOR YOKES

SILVERTONE 80-56-4G	\$4.95 Ea.
MAGNAVOX—361340	\$4.00 Ea.
MAGNAVOX—361395	\$4.95 Ea.
SYLVANIA—51-29986-2	\$6.95 Ea.
DY95-AC—Y 109 (EQUIV.)	\$6.98 Ea.
MOTOROLA (QUASAR)	\$4.95 Ea.

TUNERS—NEW WITH TUBES

G.I. PARALLEL-6GS7-6HA5	\$3.95
SILVERTONE SERIES 5LJ8-3HA5	\$3.95
SYLVANIA TRANS. 54-29331-3	\$5.95
STANDARD COIL PAR. 6GJ7-6HA5	\$6.95
SARKES TARZIAN PAR. 6GJ7-6HA5	\$6.95
PHILCO SERIES-5GJ7-3HQ5	\$3.95

COLOR FLYBACKS—COLOR FLYBACKS

EQUIV. FLY 277-H0601C	\$7.95
RCA—143536-501	\$7.95
RCA—1435637-501	\$7.95
EMERSON—738229	\$4.95
5 Asst'd Stereo Cart.	\$6.95
20 Asst'd ASTATIC NEEDLES	\$3.29
STEREO TURNOVER TONEARMS	\$1.69 Ea.
10 Asst'd. IF Transformers	\$1.00
50 Asst'd Wire Wound Resistors	\$2.49
20 Assorted Mallory Controls	\$2.00
10 HV Anode Leads-B/W Sets	\$1.00
5—40KV HV ANODE LEADS	\$1.00
COLOR CRYSTALS 3.58 Mhz	2 for \$1.98
RCA DAMPER DIODES	2 for \$2.95
100 Asst'd Bypass Cond.	\$4.95
100 Asst'd 1&2 Watt Res.	\$1.39

DIODES-TRANSISTORS

25—IR—2.5 Amp.—1000 PIV	\$4.95
20—1 Amp. 1000 PIV TOP HATS	\$3.19
20—1 Amp. 1000 PIV Epoxy Rect.	\$3.19
10—DD-04—Dual Diodes	\$2.98
10—DD-05—Dual Diodes	\$2.98
25—IN34A Crystal Diodes	\$2.00
5—Boost Rect.	\$2.00
18.5 KV FOCUS RECT.	3 for \$2.49
50 Asst'd Terminal Strips	\$1.19
COLOR CRT BOOSTER 90%	\$4.95 Ea.
COLOR CRT BOOSTER 70%	\$4.49 Ea.
BLUE LATERAL MAG/PURITY	2 for \$2.98
25 Asst'd Filter Cond. (CANS)	\$4.95
25 Asst'd Filter Cond. AXIAL	\$4.95
ZENITH VOLT TRIP-212-109	\$5.95 Ea.
ZENITH IC—212-45	\$2.95 Ea.
10 Asst'd Align. Tools	\$1.98
66 Meg.—IRC HV Resistor	3 for \$2.00
53 Meg.—IRC-HV Resistor	3 for \$2.00
5-CRT SOCKETS COLOR 90%	5 for \$2.00
50 Assorted Fuses	\$2.00

MINIMUM ORDER \$15.00

SEND FOR FREE CATALOG

TUBES UP TO 80% OFF

SEND CHECK OR
MONEY ORDER

TV TECH SPECIALS

P.O. BOX 603

Kings Park, L.I., New York 11754

Circle 82 on reader service card

NEW

from endeco



The Pencil Soldering Iron with Operating Light, 2 Heats and On/Off Switch

\$10.95
NET



Model 540S
Soldering Iron
Length 8 1/2"
Weight 2 oz.

- Light shows when it's on
- 2 heats—20w and 40w—for any job
- Ironclad tips for longer life
- Cool, unbreakable polycarbonate handle
- Burn-resistant neoprene cord
- Converts to a desoldering iron with low cost attachment

The Pencil Desoldering Iron with Operating Light, and On/Idle/Off Switch

\$15.95
NET

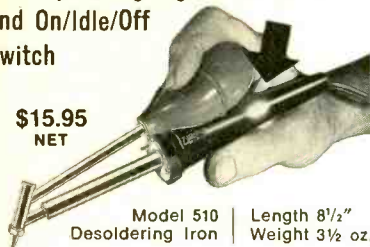

Model 510
Desoldering Iron | Length 8 1/2"
Weight 3 1/2 oz.

- Light shows when it's on
- Operates at 40w; idles at 20w for longer tip life
- 6 tip sizes available to handle any job
- Cool, unbreakable polycarbonate handle
- Burn-resistant neoprene cord
- Exclusive new bracket insures alignment, prevents damage

New kits also available!

- Soldering Kits • Desoldering Kits
 - Soldering/Desoldering Kits
- See your distributor or write ...



5127 EAST 65TH ST.
INDIANAPOLIS,
INDIANA 46220
PHONE 317/251-1231

enterprise
development
corporation

Circle 75 on reader service card

EQUIPMENT REPORT

(continued from page 99)

coming quite popular with manufacturers. Sylvania in the Jan. 1971 issue of its Service News, published a full set of curves for its D-12 color TV chassis, one for each transistor in it. You can repeat this test for any solid-state set, and either draw or photograph the curves for future reference. In-circuit curves for similar stages tend to look a lot alike; for instance, first and second video i.f. stages, audio amplifiers, and so on.

In-circuit tests are simple, in principle. Since a curve-tracer tests transistors by turning them on, out-of-circuit; it should do the same, in-circuit, and it does. Due to the numerous shunt reactances present, the curves won't look like the out-of-circuit curves, but they will show a distinct "family" of curves, indicating that this transistor is capable of working.

This is strictly a GO/NO-GO test, for the transistor and doesn't indicate the quality of other parts in the circuit. However, it will give you the same basic reactions that other in-circuit testers do. If the transistor tests bad in-circuit, but tests good out-of-circuit, this shows that there is a bad part in that stage somewhere.

I gave it my best shots; three-and four-stage direct-coupled audio amplifiers. It showed curves on all four of the transistors. I tried it on a CATV line-amplifier, with very low reactances across most of the transistors. Came up smiling. In fact, we found the bad transistor in a known-bad amplifier. TV antenna booster, same results.

The Model A will do quite a few other tricks which we aren't able to cover here. These are all in the manual. This can be a money making instrument, properly used, and a welcome addition to your instrumentation. **R-E**

SPECIAL!

IC/Transistor Tool Kit

18 selected tools — screwdrivers, pliers, tweezers, microscope, etc. for IC and transistorized circuits. Each in its own slot in a neat case.



While They Last... Only \$39⁹⁵

Ask for FREE Tools Catalog

**ELECTRONIC TOOLS DIVISION
C. H. MITCHELL CO.**

14614 Raymer St. / Van Nuys, CA 91405

CHM-117

HIGHLY
PROFITABLE

ONE-MAN ELECTRONIC FACTORY

Investment unnecessary, knowledge not required, sales handled by professionals. Ideal home business. Write today for facts! Postcard will do. Barta-BY, Box 248, Walnut Creek, CA 94597.

TOOL KITS

FIELD ENGINEER TOOL KIT JTK-17



Includes more than 100 tools!

Write for brochure

More than 100 fine tools used for servicing in the field. Used on communications equipment, business machines, computers, all kinds of electronic systems. All tools and VOM tester are furnished in deluxe attache' case.

FIELD ENGINEER ATTACHE CASES



Five styles available

Pockets for 60 tools. Solid wood frame. Scuff-proof Mar-velon cover, all brass hardware. Compartments in base for spare parts and a test meter. Dimensions: 18 x 13 x 4-1/2". Write for catalog.

Free Catalog

ELECTRONIC ASSEMBLY TOOLS

Lists more than 1700 items—pliers, tweezers, wire strippers, vacuum systems, relay tools, optical equipment, tool kits and cases.



JENSEN TOOLS and ALLOYS
4117 N. 44TH STREET, PHOENIX, ARIZONA 85018

Circle 76 on reader service card

EDI

THOUSANDS OF BARGAINS—TOP VALUES IN Electronic Parts

Transistors, Modules, Speakers, Stereo, HI-FI, Photo Cells and thousands of other Electronic Parts. Send for **FREE** Catalog

ELECTRONIC DISTRIBUTORS INC.
Dept. TA-2, 4900 Elston
Chicago, Ill. 60630

RUSH CATALOG

Name _____

Address _____

City _____ State _____ Zip Code _____

Circle 77 on reader service card

market center

WANTED

"CASH" paid for unused teletype parts and assemblies. "PHILMAR", Box 96, Morrisonville, N.Y. 12962 518-561-3479

QUICK cash for electronic equipment, components, unused tubes. Send list now! BARRY, 512 Broadway, New York, N.Y. 10012, 212 Walker 5-7000

BUSINESS OPPORTUNITIES

START small, highly profitable electronic production in your basement. Investment, knowledge unnecessary. Postcard brings facts. BARTA-AY, Box 248, Walnut Creek, Calif. 34597

ELECTRONIC ENGINEERING & INSTRUCTION

CLASSIFIED COMMERCIAL RATE (for firms or individuals offering commercial products or services) \$1.00 per word, minimum 10 words.
 NONCOMMERCIAL RATE (for individuals who want to buy or sell personal items) 70¢ per word, no minimum.
 FIRST WORD and NAME set in bold caps at no extra charge. Additional bold face at 10¢ per word. Payment must accompany all ads except those placed by accredited advertising agencies. 10% discount on 12 consecutive insertions, if paid in advance. Misleading or objectionable ads not accepted. Copy for January issue must reach us before November 1.

CLASSIFIED ADVERTISING ORDER FORM

1	2	3	4	5
6	7	8	9	10
11	12	13	14	15
16	17	18	19	20
21	22	23	24	25
26	27	28	29	30
31	32	33	34	35

No. of Words { @ .70 Non-Commercial Rates } = \$
 { @ \$1.00 Commercial Rate } = \$
 No. of Words in bold face @ .10 = \$

Total Enclosed \$\$

Insert time(s)

Starting with issue

Payment must accompany order unless placed through accredited advertising agency 28

NAME

ADDRESS

CITY STATE ZIP

SIGNATURE

MAIL TO: RADIO-ELECTRONICS, CLASSIFIED AD DEPT., 200 PARK AVE. SOUTH, NEW YORK, N.Y. 10003

DEGREE Program in Electronics Engineering. Our 27th Year! Free literature. Cook's Institute, Dept. 14, Box 10634, Jackson, Miss. 39209.

SHORTCUTS to success! Highly effective, profitable short courses. (75 choices). Study at home. Diploma awarded. Our 27th year. Free literature. CIEE-E. Box 10634, Jackson, Miss. 39209

TV tuner repairs—Complete course details, 12 repair tricks. Many plans. Two lessons, all for \$1. Refundable. FRANK BOCEK, Box 3236 (Enterprise), Reading, Calif. 96001.

LOGIC newsletter, design and construction, sample copy \$1.00. LOGIC NEWSLETTER, Box 252, Waldwick, N.J. 07463

YOUR Ideas are worth big money. Exciting new book tells secrets. Free details. NEOTEK (REA), 19309 Revere, Detroit, Mi. 48234

MAN 3M	7400dip
0.127" High LED 7-Segment	7400.....\$.35
Displays All Numbers and Nine Letters	74H00..... .50
Compact Spacing--5 Per Inch	7401..... .35
Bright Red 400FT-L at 10 MA Per Segment	74H01..... .50
	7402..... .40
	7404..... .35
	74H04..... .50
	7405..... .35
	74H05..... .50
Each..... \$3.00	74121..... 1.60
Ten or more for..... 2.50	7413..... 1.15
	7410..... .35
	7420..... .35
	74L20..... .50
	74H20..... .50
	74H22..... .50
	7430..... .35
	74L30..... .50
	7440..... .35
	74H40..... .50
	7441..... 1.60
	7442..... 1.30
	7446..... 1.75
	7447..... 1.75
	7448..... 1.15
	7450..... .35
	7451..... .35
	74H51..... .50
	7453..... .35
	74H53..... .50
	7454..... .35
	74L54..... .50
	7460..... .35
	74L71..... .30
	7472..... .50
	74L72..... .60
	7473..... .65
	74L73..... .90
	7474..... .65
	74L74..... .90
	74154..... 2.50
	7476..... .70
	7480..... .65
	7483..... 1.30
	7489..... 4.75
	74192..... 2.50
	7490..... 1.50
	7491..... 1.15
	7492..... 1.15
	7493..... 1.75
	7495..... 1.25
	74L95..... 2.00
	74107..... .70
	74H30..... .50
	74123..... 2.00
	74193..... 1.50
	74195..... 1.10

LED's
MV-50 Red Emitting 10-40MA @ 2V \$.25; 5/\$1.00
MV-5054 Red LED 15-100MA @ 2V \$.30; 10/\$2.50
MV-10B Visible Red 5-70MA @ 2V \$.30; 10/\$2.50

RCA 2010
Nimitron Digital Display Tube, Incandescent Five Volt Seven Segment
6" High Numeral Visible From 30 Feet
Standard Nine Pin Base (Solderable)
Left Hand Decimal Point Each... \$ 5.00
5 for... 20.00

CTS005
A Single MOS Chip With All The Logic Necessary For A --Twelve Digit--Four Function Calculator With An Extra Storage Register For Constant or Memory Application
28 Lead DIL Package
Capabilities (+, -, x, +)
Chain Calculations
True Credit Balance Sign Display
Automatic Keyboard De-bounce
Single Voltage Supply is Possible

Complete With Data... \$14.95
 Data Only..... 1.00
 (Refundable With Purchase of Chip)

General Telephone	CMOS
Touch-Tone, Encoding, Programming Devices. 10 Push-button Switches. Size: 3" x 2 1/4" x 1"	CD4001..... \$.75
only \$5.95	CD4002..... .75
	74C00..... .75
	CD4012..... .75
	CD4023..... .75

SINGLE CHIP 40 PIN	LINEARS
Add, Subtract, Multiply, and Divide	LM100..... \$1.00
12-Digit Display and Calculate	LM309H..... 1.00
Chain Calculations	LM309K..... 2.00
True Credit Balance Sign Output	NE5556..... 1.00
Automatic Overflow Indication	741(TO-5)..... .65
Fixed Decimal Point at 0, 2, 3, or 4	1595 4-multiple quadrant..... 2.00
Leading Zero Suppression	747..... 1.00
Data Only..... \$1.00	709..... .45
(Refundable with purchase of Chip)	710..... .50
Complete with Data... 9.95	711..... .40
	723 DIP..... 1.00
	748(TO-5)..... 1.00

MOS DYNAMIC SHIFT REGISTERS TO-5	POWER SUPPLY SPECIAL
MMS02 Dual 50 Bit 1.25	723 T (TO-5) variable regulator chip 1-40V, + or - output @ 150MA 10A with external pass transistor... With diagrams for many applications.
MMS06 Dual 100 Bit 1.75	Each..... \$.75
MMS006 Dual 100 Bit 1.50	Ten for..... 5.95
MMS013 1024 Bit 2.25	TRIAC
MMS016 512 DIL 1.50	2N6344 600V 8A TO-220..... \$.65
STATIC SHIFT REGISTERS	ZENER DIODES
MMS04 Qual 16 Bit 1.50	1N4651..... 3.9V
MMS05 Dual 32 Bit 1.75	1N4735..... 6.2V
MMS50 Dual Differential Analog Switch 2.50	1N4740..... 10.0V
	Each..... \$.50

SEND FOR FREE FLYER!!	C.O.D. PHONE ORDERS
Accepted--\$10 MINIMUM	
All IC's new and fully tested. Leads plated with gold or solder. Orders for \$5.00 or more are shipped prepaid, smaller orders--Add 35¢. California residents add Sales Tax. IC's shipped within 24 hours.	
BABYLON ELECTRONICS	P. O. Box J Carmichael, CA (916) 966-2111

Circle 84 on reader service card

LED READOUTS at LOW COST

- Factory Tested • 14-Pin DIP Socket Size
- Electrically Similar To MAN 1 Type
- Character .34 Size .75x.4x.11.5v@ 20mA/Sec.
- \$2.95/50-99 Qty. \$9.99/100-49
- \$3.50/1-9 Add \$1.00/unit for green LED Lamps (Red) ... 39¢ each
- Large LED Readouts \$19.00 each
- Character 2.5" Terms: add postage



LOGIC INSTRUMENT DEVICES
PO BOX 7, Methuen,
Massachusetts 01844

REBUILD YOUR OWN PICTURE TUBES?

With Lakeside Industries precision equipment, you can rebuild any picture tube!

For complete details, send name, address, zip code to:

LAKESIDE INDUSTRIES
3520 W. Fullerton Ave.
Chicago, Ill. 60647
Phone: 312-342-3399

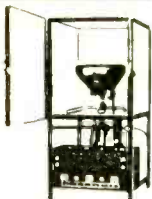

A NEW INSTRUMENT TO USE WITH YOUR SCOPE MULTITRACER



Use with your present Oscilloscope to trace Resistors, Capacitors, Transformers, Diodes, Transistors, Zeners, Tristors, most Semiconductors, IC's, etc. Also shows continuity, in-circuit and go/no-go checks. Complete with diagrams and instructions. No internal scope connections. For medium or small production runs or for hobbyist, experimenter, engineer, or ham.

ONLY \$19.95—CHECK OR MONEY ORDER WHY PAY MORE?

BOX 14, LESCO ELECTRONICS, SKOKIE, ILL. 60076

DIGITAL:THEORY,DESIGN, CONSTRUCTION

LOGIC NEWSLETTER ©

SAMPLE COPY \$ 1.00
LOGIC NEWSLETTER
POB 252
WALDWICK,N.J. 07463

TUBES

RADIO & TV tubes 36¢ each. One year guaranteed. Plus many unusual electronic bargains. Free catalog. **CORNELL**, 4217-E University, San Diego, Calif. 92105

RECEIVING & industrial tubes, transistors. All brands biggest discounts. Technicians, hobbyists, experimenters—request free giant catalog and save! **ZALYTHON**, 489 Jericho Turnpike, Mineota, N.Y. 11501

SAVE money on parts and transmitting-receiving tubes, foreign-domestic. Send 25¢ for Giant Catalog. Refunded first order. **UNITED RADIO COMPANY**, 56-R Ferry Street, Newark, N.J. 07105

PLANS & KITS

JOYOUS TV viewing! Silent commercials—sound returns **automatically!** Novel, ingenious idea. **Fun** project. Ordinary parts. Detailed plans 2.00. **HOBBY ELECTRONICS**, Box 2172, Capistrano Beach, Calif., 92624

NEW! Computer laboratory! Six digital integrated circuits, transistors, readouts. Dozens of experiments. Design your own circuits. Very low cost! Guaranteed. Free information. **LINDSAY**, Box 12-R, Bradley, Ill. 60915.

JOYOUS TV viewing! Silent commercials—sound returns **automatically!** Novel, ingenious idea. **Fun** project. Ordinary parts. Detailed plans 2.00. **HOBBY ELECTRONICS**, Box 2172, Capistrano Beach, Calif., 92624

"32-FUNCTION digital computer kit, 24-pin IC, 12 transistors, complete instructions, now only \$14.00. **ELECTRONICS**, Box 278A, Cranbury, N.J. 08512."

IC PRICES SLASHED

FACTORY FIRSTS

NATIONALLY KNOWN BRANDS SATISFACTION GUARANTEED

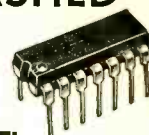

DIGITAL TTL

ITEM 1-99 100-999*	ITEM 1-99 100-999*
7400N ...32¢... 28¢	7472N ...40¢... 35¢
7401N ...32¢... 28¢	7473N ...52¢... 45¢
7402N ...32¢... 28¢	7474N ...52¢... 45¢
7403N ...32¢... 28¢	7475N ...61¢... 55¢
7404N ...35¢... 31¢	7476N ...60¢... 55¢
7410N ...32¢... 28¢	7487N ...60¢... 55¢
7420N ...32¢... 28¢	7490N ...1.00... 85¢
7430N ...32¢... 28¢	7492N ...1.00... 85¢
7440N ...32¢... 28¢	7493N ...1.00... 85¢
7441N ...1.75... \$1.45	7495N ...1.30... \$1.15
7442N ...1.35... \$1.15	74107N ...55¢... 50¢
7447N ...1.30... \$1.10	74121N ...70¢... 60¢

*MIXED TTL PRICES

LINEAR INTEGRATED CIRCUITS

709C MINIDIP .60¢	10/\$ 5.50	100/\$ 51
723C DIP1.15	10/\$11.50	100/\$100
741C MINIDIP ..60¢	10/\$ 5.50	100/\$ 47
748C MINIDIP .80¢	10/\$ 7.50	100/\$ 70
558C MINIDIP \$1.25	10/\$12.00	100/\$110
NE565A DIP\$3.57	10/\$30.00	
LM309K TO-3 ..\$2.50	5/\$11.25	

GENERAL PURPOSE SILICON TRANSISTORS

2N3638 PNP20¢	10/\$1.65	100/\$15.00
2N3638A PNP22¢	10/\$1.80	100/\$16.50
2N3641 NPN23¢	10/\$2.00	100/\$17.50
2N3643 NPN23¢	10/\$2.00	100/\$17.50
2N5133 NPN15¢	10/\$1.25	100/\$10.00
2N5134 NPN15¢	10/\$1.25	100/\$10.00
2N5137 NPN18¢	10/\$1.50	100/\$13.65
2N5138 PNP15¢	10/\$1.25	100/\$10.00
2N5139 PNP15¢	10/\$1.25	100/\$10.00
2N3055 NPN\$1	10/\$9.50	100/\$86.25

1 AMP SILICON RECTIFIERS

1N4001 50PIV12/\$1	100/\$6	1M/\$49
1N4002 100PIV11/\$1	100/\$6	1M/\$51
1N4003 200PIV10/\$1	100/\$7	1M/\$53
1N4004 400PIV10/\$1	100/\$8	1M/\$55
1N4005 600PIV9/\$1	100/\$8	1M/\$61
1N4006 800PIV7/\$1	100/\$9	1M/\$75
1N4006 1000PIV6/\$1	100/\$10	1M/\$83

SILICON SIGNAL DIODES

1N4148 (1N914 equiv.) 20/\$1	100/\$4.50	1M/\$35
------------------------------	------------	---------

ELECTROLYTIC CAPACITORS

Values from 1 usd through 2200 ufd. Competitive prices listed in latest flyer.

MOLEX IC SOCKET PINS

100/\$1.00	200/\$1.80	300/\$2.60	500/\$4.20
700/\$5.80	1000/\$8.20	ea addn	1000/\$7.50

DISPLAY DEVICES

5 VOLT 7 SEGMENT TUBE	\$3.75
DISPLAY KIT (TUBE+7447+7475+7490)	\$6.15
	3/\$17.50
7 SEGMENT LED (MAN-1 TYPE)	\$4.00
DISPLAY KIT (LED+7447+7475+7490+RESISTORS)	\$6.40
	3/\$18.25

1/4 & 1/2 WATT 10% RESISTORS

1/4W 5¢ 30/\$1.20, 100/\$3.00, 500/\$13.75	as low as 1.7¢ ea in quantity-see catalog
1/2W 4¢ 30/90¢, 100/\$2.50, 500/\$11.25	as low as 1¢ ea in quantity-see catalog

COD orders accepted for same day shipment. Call 218 681 6674.

Free Catalog—Large Quantity Discounts—Orders Less Than \$10.00 Add 25¢—Others Postpaid

DIGI-KEY PRICE PACESETTER FOR QUALITY IC'S
BOX 126H THIEF RIVER FALLS, MN56701

HIGH POWER TRANSISTOR ASSEMBLY

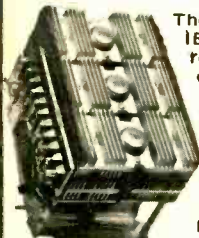

These heavy duty assemblies were removed from IBM computers, where they were used as series regulators in the low voltage supply. Each unit contains 6 150 watt PNP germanium power transistors, each mounted on its own double sided multi ribbed heat sink. These transistor heat sink combinations come apart to make 6 individual units. Also contains 20 amp. Heinemann circuit breaker with extra spdt switch contacts, 8000 Mfd. 15 volt computer grade capacitor, 2 large power resistors, double PC edge connector and more. A rare bargain.

10 lbs. STOCK NO.F5101 10.00 ea. 2/19.00 3/25.00

MINIATURE STEREO AMPLIFIER



This 2"x7" board is a complete stereo amplifier. It requires 12 volts to be operational. Has tone, balance and volume controls. Output is 2 watts per channel. Wt. 1 lb.

STOCK NO. F5102 9.50 ea. 2/17.50

COMPUTER GRADE CAPACITORS

MFD.	VOLTS	STOCK	PRICE
20,500	10	A2336	1.25 6/7.00
40,000	10	A2026	1.50 6/8.00
74,000	10	A2118	1.75 6/9.00
150,000	10	A2254	2.25 5/10.00
60,000	20	A2249	2.25 5/10.00
48,000	25	A2337	2.25 5/10.00
5,000	35	A2338	2.00 6/10.00
5500	40	A2339	2.25 5/10.00
60,000	50	A2340	3.00 4/11.00
3500	55	A2221	1.50 6/8.00

IC GRAB BAG

20 Integrated circuits, TO-5's, flat packs and dual in lines, marked and unmarked. RTL, DTL and TTL. Plus reprint of article "How to test unknown ICs. STOCK NO.F3055 1.50 per Pk. 4/5.00

Include sufficient postage. Excess will be refunded. Send for new Winter catalog. 56 pages of electronic bargains. Min. order \$ 3.00

DELTA ELECTRONICS CO.
BOX 1, LYNN, MASSACHUSETTS 01903
Phone (617) 388-4705

For faster service

USE ZIP CODE

on all mail

Circle 85 on reader service card

Circle 87 on reader service card

Opto Electronics Sale

LIGHT EMITTING DIODE GaAs INDICATORS

- 2-MV1*, Amber, visible jumbo epoxy lens upright. \$1.00
- 1-MV2*, TO-18, Dome, green, visible. 1.00
- 1-MV-2*, green small dome, green diff. 1.00
- 1-MV-2*, clear small plastic dome, green diff. lite. 1.00
- 1-MV-3*, micro-mini 'pin head' dome, TO18, green lite. 1.00
- 3-MV3*, visible, 'coax pin pak', red, mini dome lens. 1.00
- 1-MV4*, stud, high power, red, 2-watts. 3.95
- 1-MV4H*, stud, high power, hi-dome, red, 2-watts. 3.95
- 3-MV10B*, visible, red, clear, dome lens, TO-18. 1.00
- 3-MV10C, visible, red, diffused, dome lens, TO-18. 1.00
- 3-MV50*, axial leads, micro-mini dome, clear, red. 1.00
- 3-MV55*, axial, micro-mini, red lite, red lens. 1.00
- 3-MV5012*, visible, red, small dome lens. 1.00
- 3-MV5020*, jumbo clear dome, TO-18, visible, red. 1.00
- 3-MV5021*, jumbo red diffused lens, visible, lite RED. 1.00
- 3-MV5022*, jumbo red lens, visible RED lite, spade, upri. 1.00
- 3-MV5026*, jumbo red diffused lens, RED lite, spade. 1.00
- 1-MV5040*, 4-LED red array, with 6-lead pak. 1.49
- 3-MV5054*, visible, red, jumbo dome lens, upright. 1.00
- 2-MV5080*, TO-18, micro-mini, clear dome, red. 1.00
- 4-MV5082, visible, red, clear flat lens, TO-18. 1.00
- 1-MV5222*, green hi plastic dome, diffused green lite. 1.00
- 1-MV5222*, clear hi dome, diff. green lite. 1.00
- 1-MV5223*, jumbo dome, green, panel snap-in. 1.49
- 1-MV5224*, jumbo dome, GaAs, panel snap-in Yellow. 1.98
- 1-MV5491*, jumbo, Tri-State, RED, GREEN, OFF, special. 1.98
- 1-MV9000*, cartridge panel lamp, sealed, red, clear lens. 1.49
- 2-MT-2*, Photo Transistor, light sensor, TO-18. 1.00
- 2-ME-1*, infra-red, parabolic lens, pin type. 1.00
- 3-ME-3*, infra-red, invisible lite, pinhead, single lead. 1.00
- 3-ME-4*, infra-red 'invisible', TO-18, diff. dome. 1.00
- 3-ME-60*, infra-red, 'invisible', axial, micro-mini. 1.00

OPTO-COUPLERS

- MCD1* 4000V Isolation Photo Transistor. \$3.95
- MCD2* 1500V Isolation Photo Diode. 1.29
- MCT1* 4000V Isolation Photo Transistor. 4.95
- MCT2* 1500V Isolation Photo Transistor. 1.29
- MCT2-D, 1500V Isolation Photo Transistor. 1.49
- MCTS-10*, 2-000V Isolation Photo Transistor. 3.95
- MCTS-25* 25,000V Isolation Photo Transistor. 4.95

7 SEGMENT LED Readouts

All fit 14-pin IC sockets, 5V 10 to 20 ma. 0-to-9 numerals, plus letters & decimal. With spec sheets.



MONSANTO 'ALL LED' Type	Size	Color Display	Decimal	Driver	Each	Special
<input type="checkbox"/> MONSANTO MAN-1*	.27	Red	Yes	SN7447	4.50	3 for \$12.
<input type="checkbox"/> MONSANTO MAN-2*	.32†	Red	Yes	2513	6.50	3 for \$18.
<input type="checkbox"/> MONSANTO MAN-3*	.115	Red	Yes	SN7448	2.25	3 for \$6.
<input type="checkbox"/> MONSANTO MAN-3*	.115	Red	No	SN7448	1.49	3 for \$3.
<input type="checkbox"/> MONSANTO MAN-4*	.190	Red	Yes	SN7448	2.95	3 for \$8.
<input type="checkbox"/> MONSANTO MAN-4*	.190	Red	No	SN7448	1.79	3 for \$5.
<input type="checkbox"/> MONSANTO MAN-5*	.27	Green	Yes	SN7447	6.50	3 for \$18.
<input type="checkbox"/> MONSANTO MAN-8*	.27	Yellow	Yes	SN7447	6.50	3 for \$18.

* Reflective bar segments. While Monsanto all LED segments.

'REFLECTIVE LITE BAR' (SEGMENT) LED READOUTS****	Decimal	right or left				
<input type="checkbox"/> LITRONIX 707** (MAN-1)	.33	Red	Yes	SN7447	3.50	3 for \$9.
<input type="checkbox"/> LITRONIX 704*** (MAN-4)	.33	Red	Yes	SN7448	3.50	3 for \$9.
<input type="checkbox"/> OPCOA SLA-1** (MAN-1)	.33	Red	Yes	SN7447	3.50	3 for \$9.
<input type="checkbox"/> OPCOA SLA-1** (MAN-1)	.33	Red	No	SN7447	1.95	3 for \$5.
<input type="checkbox"/> OPCOA SLA-3H Giant Digit	.70	Red	Yes	SN7447	8.60	3 for \$24.
<input type="checkbox"/> OPCOA SLA-2 Plus/Minus/1	.33	Red	No	SN7447	3.50	3 for \$9.
<input type="checkbox"/> OPCOA SLA-11C (MAN-5)	.33	Green	****	SN7447	4.95	3 for \$13.
<input type="checkbox"/> OPCOA SLA-12 Plus/Minus/1	.33	Green	—	SN7447	4.95	3 for \$12.

HOBBY EXPERIMENTAL 'LED' KORNER

- 2-SPERRY SP332, twin digit, factory rejects. .33" charac, no test. \$1.00
- 1-OPCOA SLA-11*, like MAN-5, green, 1-or-more segs gone. .33" charac. \$1.29
- 1-OPCOA SLA-13*, 0.7 charac. readout, 1-or-more segs missing. \$1.29
- 5-MONSANTO opto isolators, no test, 1500V. \$1.00
- 10-LED HOBBY SURPRISE, asst. types, factory rejects, no test. \$1.00
- 1-OPCOA SLA-10*, MAN-1, red, .33" charac. 1-or-more segs gone. \$1.00
- 1-MONSANTO MAN-4, 10" charac. 1-or-more segs missing, red. \$1.00
- 3-MONSANTO MAN-3, (the claws) 12" charac, red, some segs gone. \$1.00

SPERRY "ORANGE" TWIN DIGIT ARRAY

Type SP332, each digit is individually controlled, operates off 180VDC, 100 ua, 200 mw. Color: ORANGE. 7-digits, glass protection over digits. Character height 1/2". PC mount. Size: 3/4" x 3/4". 9-pins per digit. Divisor: SN7447.

\$5.95

3 for \$15.

Each digit is 7-segment LED (MAN-3 type) and internally "multiplexed" and driven by one SN7448. Similar to DL-33 by Litronix, intended for calculators, clocks, test equipment, etc. Encapsulated in red transparent epoxy in 14-pin dip package. Character size: 12 x .077. Requires 5V 10 ma.

3 LED DIGITS ON A DIP \$8.88

LED MITY DIGIT "DCM'S"

Scientific Devices "Digital Counting Modules" outperform any other DCM on the market today. More features than ever before! Not gaseous, not incandescent, not nixie but the modern LED. Choose from such famous manufacturers as Monsanto's MAN-1, MAN-4, Litronix 707 and 704, Opcoa's SLA-1 (the last 4 having character heights of 0.33 at no extra charge). Each kit includes 3x2" p.c board with finkers for a FREE edge connector, side-mounting dip socket, LED readout of your choice, resistors, 3 IC's, and Molex connectors (this ELMINTES SOLDERING YOUR IC's) and booklet. INCLUDES P.C. EDGE CONNECTOR — FREE!

Only \$9.99

READOUT	Char. Maker
<input type="checkbox"/> MAN-1	.27 h. Monsanto
<input type="checkbox"/> MAN-4	.19 h. Monsanto
<input type="checkbox"/> 707*	.33 h. Litronix
<input type="checkbox"/> 704**	.33 h. Litronix
<input type="checkbox"/> SLA-1*	.33 h. Opcoa

MUX'D DIGITAL CLOCK PC BOARD

Each board properly multiplexed for 6 digits, to hold MAN-1's, MAN-3's, MAN-4's, Litronix 707 (MAN-

Your choice \$2.50) and 704 (MAN-4), and Opcoa's SLA-1 (MAN-1). Board 6 7/8" long with spec sheets.

Buy 3 Take 10%



\$1.49 HIGH POWER TRANSISTOR 3 for \$3 WITH HEAT SINK

Removed from new equipment! Includes popular 2N174 'doorknob' transistor TO-36, germanium, PNP, 150 watts, VCB0 80V, 15 amps, 40 hfe. For ignition, high power transmitters, etc. Mounted on heat sink 5 x 2 1/2 x 1 1/4".

GI 'GLASS AMP II' SPACE AGE FEATURES

Type	PIV	Sale
<input type="checkbox"/> 1N4245	200	\$.14
<input type="checkbox"/> 1N4246	400	.22
<input type="checkbox"/> 1N4247	600	.39
<input type="checkbox"/> 1N4248	800	.49
<input type="checkbox"/> 1N4249	1000	.59

Meets critical JAN specs. A glass 'ball of silicon' strength that meets JAN specs, high reliability, withstands avalanche power surges to 1K watts. ONE amp ratings with 2 amp capabilities. Axial leads.

ALLEN BRADLEY 'TRANSISTOR' POTS

Type	F. adjust.	Any 4	for \$1
<input type="checkbox"/> 75	7.5K	10.0K	
<input type="checkbox"/> 100	10.0K	20.0K	
<input type="checkbox"/> 200	25.0K	50.0K	
<input type="checkbox"/> 500	50.0K	100K	
<input type="checkbox"/> 750	100K	250K	
<input type="checkbox"/> 1.0K	250K	2 Meg	
<input type="checkbox"/> 2.5K	2 Meg	5 Meg	
<input type="checkbox"/> 5.0K	5 Meg		

ALLEN BRADLEY 'MICRO-POTS'

Type G, 1/2" dia. x 1/2" high. Mounts 1 1/4" hole, with shaft, linear, dimension proof. High free. 2 for \$1

Ohms	2.5K	5.0K	7.5K	10.0K	25.0K	50.0K	100K	250K	5 Meg
<input type="checkbox"/> 75	7.5K	10.0K	20.0K						
<input type="checkbox"/> 100	10.0K	20.0K	50.0K						
<input type="checkbox"/> 200	25.0K	50.0K	100K						
<input type="checkbox"/> 500	50.0K	100K	250K						
<input type="checkbox"/> 750	100K	250K	2 Meg						
<input type="checkbox"/> 1.0K	250K	2 Meg	5 Meg						
<input type="checkbox"/> 2.5K	2 Meg	5 Meg							
<input type="checkbox"/> 5.0K	5 Meg								

We stock Locknut Bushing & Screwdriver types at same low prices.

POLY PAKS STOCKS 'C-MOS' IC CIRCUITS

Type	Sale
<input type="checkbox"/> 74C00	\$.95
<input type="checkbox"/> 74C02	.75
<input type="checkbox"/> 74C04	1.35
<input type="checkbox"/> 74C10	.95
<input type="checkbox"/> 74C73	1.79
<input type="checkbox"/> 74C74	1.59
<input type="checkbox"/> 74C76	1.79
<input type="checkbox"/> 74C157	2.50
<input type="checkbox"/> 74C160	3.50
<input type="checkbox"/> 74C163	3.50
<input type="checkbox"/> 74C162	3.50
<input type="checkbox"/> 74C163	3.50
<input type="checkbox"/> 74C195	4.50

Type	Sale
<input type="checkbox"/> CD4001AE	\$.71
<input type="checkbox"/> CD4002AE	.71
<input type="checkbox"/> CD4009AE	1.69
<input type="checkbox"/> CD4011AE	.71
<input type="checkbox"/> CD4012AE	.71
<input type="checkbox"/> CD4013AE	1.62
<input type="checkbox"/> CD4016AE	1.62
<input type="checkbox"/> CD4023AE	.71
<input type="checkbox"/> CD4035AE	4.16

STUD 'TRIACS'

PRV	15 amp	25 amp
<input type="checkbox"/> 50	\$.65	\$.85
<input type="checkbox"/> 100	.85	1.05
<input type="checkbox"/> 200	1.25	1.45
<input type="checkbox"/> 300	1.45	1.65
<input type="checkbox"/> 400	1.85	1.95
<input type="checkbox"/> 500	2.25	2.25
<input type="checkbox"/> 600	2.65	2.65

- MAN-1
- MAN-3
- MAN-4
- Litronix 707 (MAN-1*)
- Litronix 704 (MAN-4**)
- Opcoa SLA-1 (MAN-1*)
- 6-MAN-3a's for above board. \$9.50

CALCULATOR KEYBOARD

9.95 3 for \$27

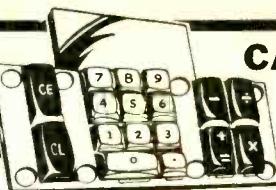

Properly etched, drilled, "MULTIPLYED," with proper diodes. Ready to go! Used with our own CAL TECH's 5001 chip advertised at \$ 9.95 or equal to Cal Tech or Mostek chip. Keyboard uses the new manufactured by OAK, printed-circuit low-profile FEATHER TOUCH switches. 0-to-9 in white with black letters. Decimal white with black dot. CE, CL and the 4 function switches are in blue with white characters. Designed by top maker. Size: 6 1/2 x 4 1/2 x 1/2". All etched connections link to take a 12-pin edge connector.

- Cal Tech 5001 12-digit calculator 28-pin DIP for \$ 9.95
- Keyboard, 5001 'chip', and 12 MAN-3's, specs \$35.00
- Twelve MAN-3's for above. \$17.50
- Twelve MAN-4's for above. \$32.00
- Twelve MAN-1's for above. \$42.00

OAK FEATHER-TOUCH SWITCHES

For RTTY Printed Circuits For Unique Panel Switches

Mfd. by OAK (Ham's note, same as used in Keyboard Calculator, SPST. Normally Open, 24V 1 amp contacts. Characters and letters easily changed. 3/8" high. Printed circuit. White top, black numbers.

No.	8*	9*	0*	CE†	CL†	+	-	×	÷
<input type="checkbox"/> 0*	1*	2*	3*	4*	5*	6*	7*	*	*
<input type="checkbox"/> 1*	2*	3*	4*	5*	6*	7*	*	*	*
<input type="checkbox"/> 2*	3*	4*	5*	6*	7*	*	*	*	*
<input type="checkbox"/> 3*	4*	5*	6*	7*	*	*	*	*	*
<input type="checkbox"/> 4*	5*	6*	7*	*	*	*	*	*	*
<input type="checkbox"/> 5*	6*	7*	*	*	*	*	*	*	*
<input type="checkbox"/> 6*	7*	*	*	*	*	*	*	*	*
<input type="checkbox"/> 7*	*	*	*	*	*	*	*	*	*

Kit of 17 above switches for keyboard \$7.50

12-DIGIT "CALCULATOR CHIP"

Similar to Mostek 5001. Outperforms Texas 8-digit TMS1802. A 40-pin DIP. Adds, multiplies, subtracts, and divides. Used with 7-segment readouts, Nixies, and LEDs. We include schematic, instructions to build calculator.

CT5001 Chip 3 for \$27. CT5002-9 Volt version of above \$9.95 CT5005-Same as above with MEMORY \$14.95

NATIONAL EQUALS ON "DIGITAL CLOCK on a CHIP"

Any 'Chip' \$12.88

Mfrs #	Description	Sale	With Spec Sheet!
<input type="checkbox"/> 5311	28-pin, ceramic, any readout, 6-digits: A-B-D	\$12.88	
<input type="checkbox"/> 5312	24-pin, ceramic, any readout, 4-digits: C-D	\$12.88	
<input type="checkbox"/> 5313	28-pin, ceramic, any readout, 24-pin, plastic, LED and incandescent readouts, 6-digits: A-B	\$12.88	
<input type="checkbox"/> 5314	24-pin, plastic, LED and incandescent readouts, 6-digits: A-B	\$12.88	

Code: A—Hold Coun. C—1 PPS Output. B—Output Strobe. D—BCD

1-MMS316, DIGITAL ALARM CLOCK FACTORY FALLOUT — \$1.49 EACH

AM RADIO ON A 'DIP' Only \$1.49
Over 50,000 pieces purchased from SPRAGUE ULX2137. Designed for superhet AM radio applications Contains two amplifiers, a mixer oscillator, age detector, and voltage regulator on a single chip. It's inflation-fighting, economy priced because we can't test 'em! With spec sheets and diagrams. 14-pin dip pak. Supply Vec 14. Money back guarantee.

100-PC. JUMBO CORNING "METAL OXIDE" RESISTOR KITS \$2.50

First time ever offered! Corning's Type C, NA, NC, and PP—all in 1 low-priced package. The FINEST RESISTOR ever made! 1% 5% 10% tol. With many different values from 150 ohms to 10 megs. Includes 1/8, 1/2, 1 and 2-watt units. Designed for critical hi-fi, military, precision eqpt. Wt. 1 lb.

"AEROSPACE" BABCOCK & LEACH CRYSTAL CAN RELAYS

All hermetically sealed. Submini, 1/6, half, and full crystal can types in 6-12-24V in asst contacts up to 4PDT, 1 amp up to 10 amps. Such types as BR40, 41, 10, 44, 16, 24, etc. Sorry, no choicing voltages or types. From factory mixtures to your Good asst. if you are spaceminded at low prices.

Size	Sale
<input type="checkbox"/> 12 for \$3.50	

POTTER BRUMFIELD MINI CAP RELAYS

Measures only 3/4 x 1 x 1 1/4". Plastic cased. Like KNP type. For pc board or socket, 14 lugs, 1-8/32 stud tool Both 4PDT. All ceramic construction, 3 amps, contacts. For r-f ant. switching. Wt. 1-oz.

Choice	Sale
<input type="checkbox"/> 115 VAC	\$2.49
<input type="checkbox"/> 24 VDC	\$3 for \$6

HI-FI 1" SQUARE MINI METERS \$1.49

Plastic case Red needle indicators

- Balancing, stereo, tape, amps.
- VU, side mtg, plus 3 minus 20 db.
- VU, front mtg, plus 3 minus 20 db. 3 for \$3.75

Terms: add postage Rates: net 30
Phone Orders: Wakefield, Mass. (617) 245-3829
Retail: 16-18 Del Carmine St., Wakefield, Mass. (off Water Street) C.O.D.'S MAY BE PHONED

15¢ CATALOG on Fiber Optics, 'IC's, Semis, Parts

POLY PAKS

P.O. BOX 942R, LYNNFIELD, MASS. 01940

U.S. GOV'T ELECTRONIC SURPLUS

• Nationally Known-World Famous SURPLUS CENTER offers finest, most expensive, Government Surplus electronic units and components at a fraction of their original acquisition cost.

IBM COMPUTER POWER SUPPLY

• (ITEM #22-938-KYZ) - Expensive regulated unit. Fine for college labs, research co's., service shops, etc. Pure DC over a wide range of voltages. DC output voltages 6, 12, 24, etc. Wide range of AC voltages available.

• Finest transformers, filters, transistor load regulation system. Independent of line voltage fluctuations. Contains five separate rectifier systems. Unit is furnished without small "regulating card" which can be easily made or can be bypassed. Data and circuit diagrams furnished. 30" x 12" x 10". 125 lbs.



Cost Gov't Over \$500.00 **\$26.95**

ONCE-IN-A-LIFETIME SPECIAL

BURGLAR-FIRE ALARM SYSTEM



• (ITEM #1135-A) - Dual alarm system gives warning of fire or break-in. Operates on 115-240V AC. Control unit, 2-kettle flash fire, 2-murcury column, 3-door window actuators, alarm bell, 100 ft. wire, instructions, 8 1/2" x 7 1/2" x 3", 11 lbs.

\$39.95

STANDARD DIAL TELEPHONE

• (ITEM #715) - Standard, commercial telephone same as used throughout U.S.A. Attractive polished black, like new condition. Use as extension phone to private systems or connect several phones together for local intercom system. Full instructions are furnished. Wt. 9 lbs.



Original Cost **\$24.50**
\$8.79

STEP-BY-STEP TELEPHONE SWITCH

• (ITEM #738) - Amazing "up-and-around" switch. Great experimental item. When used with two-wire telephone dial will select any number from 0 to 100. Make intercom or private system. Use to turn on remote lights, start motors, etc. Complete with contact bank, 13" x 6" x 5". (16 lbs.) Cost Over \$90.00



\$8.95

• Telephone dial for use with above switch when purchased at same time as switch. Order as ITEM #200A-1. Only **\$1.97**

MAGNETIC DIGITAL COUNTER (12 to 18-VDC)



• (ITEM #21-959) - Use to count electrically. Use in count number of times door is opened after business is closed, to show changing prices, laboratory work, etc. Will count 1 for each pulse and will transfer 10th count to next unit. 4 1/2" x 1 1/2" x 1 1/2"

Orig. Cost Each **\$1.99** Three For **\$4.99**
Over \$10.00

200 AMP., 50 VOLT, SILICON DIODE



• (ITEM #22-963) - A Four Star Buy! New, leading make. Heavy duty units excellent for use in 12 or 24-volt fast chargers, high current power supply systems, etc. 2 1/2" x 1 1/2" x 1 1/2". 3-10 S&E mounting breads. (1 lb.)

List Over \$15.00

\$4.98

AC PROGRAM TIMING CLOCK

• (ITEM #158) - Zenith 115-VAC unit. Use for periodic signaling, work breaks, classes, turn on radio, etc. All 411-circuit, ON-OFF switching any time in 24-hour period. Also has "skip-a-day" feature. Can be multiple programmed. 13-amp. contacts. 8 1/2" x 9 1/2" x 4 1/2". (6 lbs.)



Cost Gov't Over \$30.00 **\$15.75**

SNAP AROUND VOLT-OHM-AMMETER



• (ITEM #21-944) - Measures AC current without opening the line. Simply press handle and snap the probe around the conductor. Reads currents from .25 to 125-amps. Reads voltages to 300, reads ohms up to 500. Test motors, appliances, etc. Three current ranges, two voltage ranges. With case, test leads. 7 1/2" x 3" x 1 1/2".

\$39.95

(2 lbs.)

SPECIAL SALE

Correspondence Course In ELECTRICAL ENGINEERING



\$8.79 Prepaid in U.S.A.

\$10.79 Outside U.S.A.

• (ITEM #9-181) - Obtain technical training at low cost! Lincoln Engineering School has suspended its Correspondence Courses because of rising costs. A limited number of Electrical Engineering Courses are available, but without the examination grading service. The course consists of 15 lesson books, each with associated exams and standard answers. Book describing prize winning Home Experimental Laboratory Bench furnished at no extra cost.

RUNNING TIME METER

• (ITEM #2108) - Record number of operating hours of electric lights and electrical devices such as refrigerators, furnaces, etc. Records total hours, tenths and hundredths up to 9,999.99 hours. For 115-volt, 60-cycles. Size 4 1/2" x 3 1/2" x 2". Shipping weight 2 lbs.



\$4.39 Cost Over \$29.00

COMPUTER TRANSISTORS ON HEAT SINKS

IBM Computer Quality Units

• (#22-928) - Unit consists of one 150-watt power transistor on heavy, ribbed, aluminum heat sink. Many experimental uses. (1 lb.)

Cost Gov't Over \$10.00 **\$1.98**

• (#22-915) - Unit consists of two 150-watt power transistors, 2 pots, several diodes, capacitors, resistors, etc. on heavy, ribbed aluminum heat sinks. Ideal for use as motor speed control. (4 lbs.)

Cost Gov't Over \$35.00 **\$4.91**



ALL ITEMS SHIPPED F.O.B. LINCOLN, NEBR. Order Direct From Ad. Money Back Guarantee.

SURPLUS CENTER

DEPT. EW-113 LINCOLN, NEBR. 68501

"DIGITAL speedometer with numeric readout. Plans \$4.50. KIMTRON, Box 80134, Chamblee, Ga. 30341

ELECTRONIC combination lock solid-state. Plans \$2.00, kit \$29.95. RICHARD MEUSE, 9 Appleton Terr., Everett, Mass. 02149.

FREE catalog. Most unusual electronic kits available. Music accessories, surf, wind synthesizers, wind chimes, many others. PAIA Electronics, Box B14359, Oklahoma City, OK 73114.

DIGITAL IC manual—1973 edition—1500 types. Double listing by type & wiring diagram number. Many cross-referenced. \$3.95. ELECTRONETICS, Box 278, Cranbury, N.J. 08512

ELECTRONIC organ kits, keyboards and many components. Independent and divider tone generators. All diode keying. IC circuitry. Build any type or size organ desired. Supplement your Artisan Organ. 25¢ for catalog. DEVRONIX ORGAN PRODUCTS, Dept. B, 5872 Amapola Dr., San Jose, Calif. 95129

FOR SALE

FREE catalog. Tremendous electronics bargains. PACIFIC, Box 4192G, Mountain View, Calif. 94040.

LOW noise resistors—1/4 W, 5%, carbon film for 3.5¢ each. Fifty of one value for \$1.25. All 5% values from 10 to 3.3 megohms in stock. Specifications upon request. 75% postage and handling charge per order. Deduct 10% on orders over \$50. COMPONENTS CENTER, P.O. Box 134, N.Y., N.Y. 10038

MANUALS for Govt. surplus radios, test sets, scopes. List 50¢. BOOKS, 7218 Roanne Drive, Washington, D.C. 20021

JAPANESE new products monthly! \$1.00. Refundable. DEERE, 10639 Riverside, North Hollywood, CA

WHOLESALE prices on electronic parts. Large discounts. Free catalog. DONLYN ELECTRONICS, P.O. Box 15421, Phoenix, Arizona 85060

NEW FM deviation meters \$75.00. Free information. Write ECM, 412C N. Weinbach, Evansville, Ind. 47711.

CMOS, TTL, linears, LED's. Surplus bargains. Stamp brings free catalog. GODBOUN, Box 2673, Oakland, Calif. 94614.

FREE catalog lists resistors, tubes, transistors, rectifiers, condensers, tools, tuners, etc. etc. HYTRON HUDSON, Dept. RE 2818 Kennedy Blvd., Union City, N.J. 07087.

SEMICONDUCTOR and parts catalog. J. & J. ELECTRONICS, Box 1437, Winnipeg, Manitoba, Canada

FLASHTUBES, capacitors for automotive timing light replacement. Catalog. KOHLER ELECTRONIC Box 57, Elk, Calif. 95432.

POLICE receiver, scrambler decoders. Free catalog. Special discount priced on many CB radios. KRYSTAL KITS, 2202 S.E. 14th, Bentonville, Ark. 72712.

COLLECTORS Records of Dallas presents the largest oldies record catalogue. Over 6000 records listed for sale, 50¢ to \$150.00, years 1948 to 1972. Cost of 60 page catalogue is \$3.00, refundable with the first order. Send to COLLECTORS RECORDS, POB 44017 B, Dallas, Texas 75234.

EXPERIMENTER supplies, PC chemicals, solder, adhesives, accessories—Free catalog. TECHNICAL SERVICES, Box 687R, Arlington, MN 55307.

15 AMP CHARGER KIT

Brand new GE transformer with solid state rectifier. Assembled in minutes and ready to charge any 12 volt battery up to 15 amps. — #PK-4 \$7.50

POWER AMP TRANSFORMER

115 VAC input. Output 70 VCT at 3 amps. Makes a magnificent power amp.

#73S-43 \$7.50

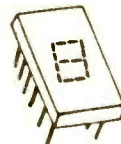

7 Segment LED display, similar to MAN-1 **\$3.50**
7 Segment LED display, similar to MAN-3 **2.00**
7 Segment LED display, similar to MAN-4 **3.50**
LED (red) 3 for \$1.00 **
LM 309K **\$2.00**

PA234 1 watt audio amp **\$1.25**
PA264 5 watt up to 25 volt regulator **1.25**
PA265 5 watt up to 37 volt regulator **1.50**
GE THYRECTOR 20 amp peak, 30 volt surge protector **5/\$1.00**
709 OP AMP TO-5 3/\$1.00
DUAL 709 OP AMP **.75**

HOW'S YOUR MEMORY

RCA MEMORY STACK ultra compact 32x32x9 **\$50.00**
MEMORY STACK 32x32x16x9 frames **100.00**
SINGLE PLANE 64x64 **10.00**
SINGLE PLANE 32x32x16 **15.00**

AM-FM RADIO \$5.50

Fully built, with AC supply, no cabinet, no speaker. Send for free catalog. Postage extra on above items.

MESHNA PO Bx 62, E. Lynn, Mass. 01904

Circle 86 on reader service card

"IN CIRCUIT" TRANSISTOR TESTER model 85

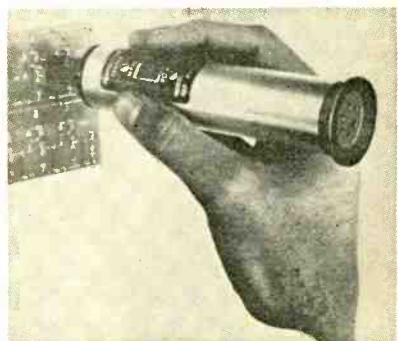

\$19.95 PREPAID MONEY BACK GUARANTEE

Places transistor into actual operation • Operates upon contact • Clear speaker tone—no visual observations to make • Tests Transistors in or out of the circuit.

A complete electronic Tester. No additional equipment required. Designed to reach into small areas. Maximum voltage applied to the base-emitter junction by Tester is 0.8 volts.

Simple to operate.

United Sales, Dept. 8690 Brightwood, Washington, D.C. 20011

Circle 89 on reader service card

"AUDIO AMP ALLEY"

Buy Any 3
Take 10%

Watts	Mfr.	Type	Case	Heat Sink	Sale
1W	Westinghou	WC334	TOS	No	\$1.49
2W	National	LM380	DIP	No	\$1.95
3-5W	G.E.	PA263	DIP	Yes	\$2.95
4W	Texas	SN76024	DIP	Yes	\$3.95
5W	SGS	TBA800	DIP	Yes	\$4.50
4W	Motorola	MFC9000*	DIP	Yes	\$2.95
Dual 2W	Sprague	2277	DIP	Yes	\$2.95
	Fairchild†	Dual Stereo Preamp	DIP	No	\$1.95

†With built-in preamp. All 9-24V, to 8-16 ohms load

WORLD FAMOUS SEMI-KON Dollar Stretchers

- 20-HEAT SINKS for all types of TO5 trans. makes 'em high power! \$1.
- 2-2N5296 35-WATT NPN PLASTIC TRANSISTORS, for NE-540 \$1.
- 2-2N6109 40-WATT PNP PLASTIC TRANSISTORS, for NE-540 \$1.
- 10-1N82 GERMANIUM UHF diode, clip-in type* \$1.
- 5-5CRs 7-AMP TO220, 6-12-24, priv. power tab \$1.
- 10-MOS FETS, 3N187, 3N200, 3N128, TO-18, Fairchild* \$1.
- 5-5CRs & TRIACS up to 10 amps, 6-12-24 prv. studs too \$1.
- 2-2N3819 Texas N channel, 6500 umho TO-18 \$1.
- 2-2N2646 UNIUNIONS, plastic transistors, Texas \$1.
- 5-2N107, GE, most commonly used pnp, germanium \$1.
- 50-SILICON, glass rectifiers, computer, axial leads \$1.
- 50-GERMANIUM, glass rectifiers, signal, axial leads \$1.
- 5-2N107, GE, 1.5 amp, germanium, pnp, trans-4 \$1.
- 6-1-AMP 1000 PIV, opxy, submini, silicon rectifiers \$1.
- 30-500mW ZENERS, axial, 4, 6, 9, 10, 12V rectifiers \$1.
- 4-2N3055, HOBBY, 40W npn silicon transistors, TO-3 \$1.
- 30-3-AMP RECTIFIERS, silicon, opoxy, assorted V. axial* \$1.

- 1 - PHOTO TRANSISTOR, with darlington amp filter, lens \$1
- 1 - PHOTO TRANSISTOR, with darlington amp, 2N5777, GE \$1
- 4 - PHOTO CELLS, Clairex, pancake, 40K-70 ohms \$1

- 1-2N3055 npn, 100W, 15A, TO-3 transistor \$1.
- 1-ERFRO TRIGGER DIODES for SCRs & Triacs \$1.
- 2-FETs 2N5467 N channel, 5000 umhos, TO-18 plastic \$1.
- 10-1N914 fast switch diodes, silicon, .4 nanoseconds \$1.
- 2-6 AMP TRIAC 200 PRV TO-5 \$1.
- 40-1TT MICRO MINI RECTIFIERS silicon porcelain to 1kV* \$1.
- 30-WORLD'S SMALLEST RECT. & zeners, 1W, assorted volts* \$1.
- 4-2N4269 Nixie tube driver transistors 100V, npn \$1.
- 2-PUNTS prog. uni-transistors similar to GE-D13T \$1.
- 2-6000 PIV 50 mil opoxy rectifiers, axial leads* \$1.
- 10-BENDIX 25 WATT "pellet" power transistors, silicon* \$1.
- 1-PHOTO ELECTRIC FET, 10,000 ohms, n channel \$1.
- 4-80 WATT, 2N1488, silicon, TO-3, 60 Voo, npn \$1.
- 4-1000 HFE DARLINGTON Transistors, TO-18 case \$1.
- 1-2N5036 HI-PWR plastic trans, 100 voo, 7 amp, 85 watts \$1.
- 4-2N5296 HOBBY, 5 watts, plastic powers, NPN \$1.
- 4-2N6109 HOBBY, 40 watts, plastic powers, PNP \$1.
- 5-PLASTIC 35W powers, npn, silicon, hobby 2N6121 \$1.
- 5-PLASTIC 35W powers, pnp, silicon, hobby 2N6124 \$1.
- 2-MOS FETs, N channel 10K umos 3N128, TO-18, RCA \$1.
- 2-MOS FETs, DUAL GATE, N chan, 3N187, TO-18, RCA \$1.
- 2-MOS FETs, DUAL GATE, N chan, 3N140, TO-18, RCA \$1.
- 4-RCA 2N3600 NPN, UHF transistors, tv-fm, TO-18, 1000mc \$1.
- 1-300V PLASTIC POWER TAB transistors, 6A \$1.

"EYE C" SPECIAL EKONOMY BARGAINS!

- 10-555 HOBBY TIMER special, in the mini DIP packs* \$1.
 - 10-NATIONAL 301 and 307 HOBBY OP AMP SPECIAL TO5* \$1.
 - 15-NATIONAL & SINECNET TTL dip special, all marked* \$1.
 - 3-1-WATT AUDIO AMPLIFIERS, Westinghouse, TO-5 \$1.
 - 15-709 FLAT PAK OP AMP, 100 \$1.
 - 50-710-711 flip-flop COMPARATORS, untested \$1.
 - 4-DUAL 709, dip pak, op amps, untested \$1.
 - 5-7474D triggered flip-flops, dip, no test \$1.
 - 2-1101 266 BIT ram special, dip, no test \$1.
 - 5-SN7447 7-SEG. decoder-driver fallouts \$1.
 - 40-709-749, 549, 689, 749 \$1.
 - 5-MOS REGISTERS, 5013-17, mini, dips, no-test \$1.
 - 5-MOS REGISTERS, 501-6, etc., TO-5, no-test \$1.
 - 5-SN7441N, hobby, BCD-to-Nixie driver IC, DIP* \$1.
 - 1-LINEAR AMPS, 709, 710, 711, 741, TO-5 \$1.
 - 10-709 LINEAR AMPS, 741's too, DIP's \$1.
 - 5-HOBBY LINEAR AMPS, SN7424 up to 16-cell, DIP* \$1.
 - 10-RCA CA-3000 of AMPS, TO-5 case \$1.
 - 5-723 VOLTAGE REGULATORS, TO-5* \$1.
 - 4-PHASE LOCK LOOPS, hobby 566, 560, 561* \$1.
 - 10-MINI DIPs phase lock loops 709, 741, 301, 307, hobby* \$1.
 - 2-3VOLTAGE REGS, HOBBY TO-5 \$1.
 - 10-SINECNET OP AMP, 531, 533, 536, 550, 556, DIPs, TO-5* \$1.
 - 1-5311-14 CLOCK ON A CHIP, 4-or-6 digit, 24-or-28-pin* \$1.
 - 1-CALCULATOR ON A CHIP, hobby, exp. 40-pin, specs \$1.
 - 4-DECADE COUNTER, hobby special, SN7490, DIP pak \$1.
 - 1-7516 CHARACTER GENERATORS, hobby, for MAN 2* \$1.
 - 1-2513 CHARACTER GENERATOR, Hobby for MAN-2! \$1.
- *Untested, guaranteed satisfaction

SUPER-ECONOMY \$1 PARTS "DOLLAR STRETCHERS"

- 10-LARGE BARCOCK RELAYS, 24V unmarked, 2 lbs \$1.
- 1-AC/DC COILS, 9V, 110 ma, for chargers, Nicad \$1.
- 2-2.5V MICRO MINI BULBS with lens, bayonet \$1.
- 2-GUARDIAN 12VDC type 1205 DPDT 10 amps cont. \$1.
- 10-SELENIUMS 24VDC type 1 x 3/4 x 3/4". Stroke 1/2", w/plunger \$1.
- 4-LINE CORDS, 18-2, black, molded plug, 115VAC \$1.
- 15-NE-2 LAZERS, neon, for 0.02's applications \$1.
- 1-115VAC RELAY, DPST, 10 amp cont, 2 x 2 x 2 1/2 \$1.
- 100-MOLEX SOCKET connectors, for IC's, etc. \$1.
- 2-CINCH EDGE CONNECTORS, type fits .055 board. 30 cont. \$1.
- 10-TEXAS INST type silicon resistors 1-ohm to 10K, 1/4w \$1.
- 10-POINTER KNOBS, push-on, black, fluted, 1/4 shafts \$1.
- 4-MIKES, metal only 1" diameter, 2 lugs \$1.
- 4-CONTROL DATA BOARDS, 100's parts w/plugs \$1.
- 15-TRANSISTOR SOCKETS, for pnp & npn transistors \$1.
- 2-GLASS P.C. BOARDS, 6 x 6 \$1.
- 1-TTL FILAMENT XFMR, 115/1/60 to 5V @ 120 ma \$1.
- 4-CHEMRY MICRO-MICRO switches w/leaf, 3/4 x 3/4 x 1/2 \$1.
- 5-MINI HANE TOGGLE SWITCHES, 1.5 amp, 3 amps, with wire \$1.
- 10-RELAYS, crystal ran, micro's, 12-24V, unmarked \$1.
- 10-SELENIUM RECTIFIERS, 65 mil, for ac dc sets. Only 3/4" sq \$1.
- 10-SLIDE SWITCHES, SPDT, DPST, DPDT, 115/1/60, 3A \$1.
- 30-ALLEN BRADLEY MICRO MINI 1/2 watt resistors, asst. \$1.
- 30-POWER RESISTORS, 3-to-25m. square, vitreous, asst. vals. \$1.
- 10-MICRO RELAY SWITCHES, 1" long, transistor work \$1.
- 1-\$25. SURPRISE PAK, resistors, cond. transistors, etc. \$1.
- 50-TERMINAL STRIPS, 1-to-8 screw & tie lugs \$1.
- 30-SQUARE DISCS, .85mmf, to .01mf, space-savers \$1.
- 75-PRE-FORMED DISCS, condensers, printed circuit \$1.
- 60-TUBE SOCKETS, receptacles, plugs, audio, etc. \$1.
- 100-PRE-FORMED DISCS, 1/2 watt, printed circuit \$1.
- 50-COILS & CHOKES, if, rf, ant, peaks, osc, parasitic \$1.
- 60-PRECISION RESISTORS, 1/2, 1, 2w. 1% asst. vals. \$1.
- 60-TUBULAR CONDENSERS, to .5mf, to 1kv, molded too \$1.
- 30-POLYSTYRENE CONDS, finest caps made, asst. values \$1.
- 10-PANEL MOUNTED RESISTORS, 1/2, 1, 2w. 1/2w. snap-in \$1.
- 10-VOLUME CONTROLS, to 1 meg. duals too, some w/switch \$1.
- 40-MICRO MINI RESISTORS, 1/4w. 100 ohm to 1 meg. 5% \$1.
- 40-MICRO-MICRO-MINI CONDENSERS, to .05mf cerafil \$1.
- 5-IBM COMPUTER BOARDS, trans, caps, res, coils, etc. \$1.
- 10-ELECTROLYTIC CONDS, PP's, & tubular, 2 & 3 sect. too \$1.
- 6-TRIMMER P.K's, 10K 50K 250K, 1K, 25K 1/4w. snap-in \$1.
- 4-MICRO POTS w/knob, snap-in, 1/5w, 25K, 50K, 100K, 1 meg \$1.
- 30-YELLOW PACKET MYLARS, assorted values & sizes \$1.
- 10-POWER TRANSISTOR SOCKETS, for TO-3, asst. types \$1.
- 64-PLASTIC TRANSISTORS TO-18, printed circuit \$1.

KRONOS WITH "TIME BASE"*

NEW FOR 1974!

Any Type Clock less time-base with TIME BASE \$64.95

- Now two clocks in one!
- For 12VDC & 110VAC!
- Now adaptable to boats, planes & cars too!
- The only clock of its kind in USA today!
- 12 or 24-hr clock, 6-digits!

Scientific Devices introduces the new any LED Kronos digital clock. That's right, you can choose the "ALL-LED" Man-1, Man-3, and Man-4, and the new reflective bar types with the larger digits, at only one price. \$47. This is a Scientific Device first! We even have the GREEN LED readouts at a slightly extra cost. We have more for \$19.95 we have available as an (*) extra option to Naval Observatory your clock, or making it an all-purpose all-duty unit. For indoor and outdoor activity. This "TIME BASE" is the simplest on the market today with the help of one of the largest time base manufacturers for the famous digital wrist watches. Therefore, current drain is negligible, not like other cumbersome types. It's easy to construct, easy to slip into the Kronos of your choice and connect with easy instructions. Its overall design is simple and easy to construct. The kit is complete with famous black-and-white TEN-TEC cabinet, plus all accessories with booklets. Features include 3 setting controls, 1-hour per second, 1-minute per second, and hold button!

CRYSTAL TIME BASE \$19.95 FOR ANY KRONOS

Includes precision crystal, time-base IC, pc board & accessories with info.

8-TRACK CAR RADIO STEREO \$88 TAPE TRANSPORT

Contains complete 8-track stereo recording/playback unit you find in expensive car tape decks. Excellent direct replacement unit if your own does not function properly. Priced to toss away old, and replace with new. Less amplifier. Design your own hi-fi stereo systems around it. Uses standard 8-track cartridge. With hi-fi stereo tape and all its mechanical parts that go with it. Operates at 12VDC. Automatic track locating and changing plus track indicator output. 3/4 ips speed, WOW and FLUTTER less than 0.5% MU metal shield motor reduces motor noise to an inaudible one. Uses separate 739 preamp and is ready to go. Size: 5 x 5 x 2".

Lowest Prices Largest Selection TTL IC's

Brand New "DIP" Packages Order by type number! Spec sheets on request "ONLY"

Type	Sale	"DIP" Packages	Order by type number!	Spec sheets on request "ONLY"	Sale
SN7400	\$0.30	SN7430	-.30	SN7470	-.45
SN7401	-.30	SN7432	-.30	SN7472	-.45
SN7402	-.30	SN7437	-.60	SN7473	-.35
SN7403	-.30	SN7438	-.60	SN7474	-.52
SN7404	-.30	SN7440	-.30	SN7475	-.95
SN7405	-.32	SN7441	-.40	SN7476	-.95
SN7406	-.55	SN7442	1.25	SN7477	1.30
SN7407	-.55	SN7443	1.50	SN7478	-.75
SN7408	-.35	SN7445	1.50	SN7479	1.15
SN7409	-.35	SN7446	1.65	SN7480	1.15
SN7410	-.30	SN7447	1.50	SN7481	1.15
SN7411	-.35	SN7448	1.50	SN7482	1.50
SN7413	-.95	SN7449	1.50	SN7483	1.15
SN7415	-.55	SN7451	1.50	SN7484	1.15
SN7416	-.55	SN7453	-.35	SN7485	1.41
SN7417	-.55	SN7454	-.50	SN7486	1.41
SN7420	-.30	SN7455	-.50	SN7487	1.41
SN7421	-.35	SN7456	-.35	SN7488	1.41
SN7422	-.35	SN7457	-.35	SN7489	1.25
SN7423	-.35	SN7458	-.50	SN7490	1.50
SN7425	-.30	SN7459	-.35	SN7491	1.50
SN7426	-.37	SN7462	-.35	SN7492	1.30
		SN7464	-.50	SN7493	1.30
		SN7465	-.50	SN7494	1.30
		SN7496	1.30	SN7495	1.30
				SN7496	1.30

Buy 3 or more, 10% discount

NATIONAL 'OP' AMPS BUY ANY 3 - TAKE 10%

Type	Description	Sale
LM-300	Super 723 V. reg.	\$1.49
LM-301	Hi-performance amp	1.49
LM-302	Voltage follower	1.49
LM-304	Neg. V. reg.	1.49
LM-307	Pos. V. reg.	1.49
LM-308	Super 741	1.59
LM-308	Hi-Q Fet Type Op Amp	1.50
LM-309H	5V 200 mil V. reg.	1.50
LM-309K	5V 1-amp V. reg.*	2.25
LM-311	Comparator	1.50
LM-320	Minus 5V 1-amp V.R.*	1.95
LM-320	Minus 12V 1-amp V.R.*	1.95
LM-320	Minus 15V 1-amp V.R.*	1.95
LM-350	Dual peripheral driver	.59
LM-370	AGC squelch op amp	1.49
LM-371	R-F, I-F, op amp	1.49
LM-373	AM-FM, SSB, I.A.D.	.69
LM-374	AM-FM, SSB, I.V.A.D.	3.75
LM-380	2-watt audio amplifier	3.75
LM-302B	Differential RF/IF amp	1.50
LM-3070	Chrome regenerator	1.50
LM-3071	TV chroma IF amp	1.50

*TO-3 case, - others TO-5

LINEAR Op Amps

FACTORY GUARANTEED FACTORY TESTED

Type	Description	Sale
531	Hi slew rate op-amp (TO-5)	\$2.50
532	Micro power 741 (TO-5)	2.50
533	Micro power 709 (TO-5)	2.50
534	FET input op-amp (TO-5)	3.95
537	Precision 741 (TO-5)	2.50
540	70W pwr driver op-amp (TO-5)	2.50
550	Precision 723 voltage reg. (DIP)	1.17
556	5 Times faster than 741C	2.10
558	Dual 741 (mini DIP)	1.00
560	Phase lock loops (DIP)	3.25
561	Phase lock loops (DIP)	3.25
562	Phase lock loops (DIP)	3.25
565	Phase lock loops (A)	3.25
566	Function generator (A)	3.25
567	Tone generator (A)	3.25
595	Four quadrant multiplier	3.10
702C	Hi-gain, DC amp (TO-5)	.49
703C	RF-IF, amp, 14 ckts (TO-5)	1.00
704	TV sound IF system	1.50
705	Operations amp (A)	1.49
709CV	Op amp (mini DIP)	.49
710C	Differential amp (A)	.49
711C	Dual diff. comp (A)	.49
723C	Voltage regulator (A)	.95
733	DIP, Video Amp	1.75
741C	Frequency compensator 709 (A)	1.49
741CV	Freq. comp 709 (Mini DIP)	.49
747C	Dual 741C (A)	1.25
748C	Freq. adj. 741C (A)	.49
748CV	Freq. adj. 741C (mini DIP)	.49
753	Gain Block	1.75
709-709	Dual 709CV (OIP)	1.00
739-39	Dual stereo preamp	1.99
741-741	Dual 741C (A)	1.00
75150	Dual peripheral driver	.88
75154	Dual peripheral driver	.88
745512	Dual line driver	.39
PA265	5-Watt voltage regulator	1.00
ULN2300M	Op amp with SCR	1.50
CA3025	Video Audio system	1.50

(A) TO-5 or DIP dual in line pak

"MEMORY LANE"

1101	256 Bit RAM MOS	\$3.50
1103	1024 Bit RAM MOS	8.50
2513	Character Gen. ROM	12.50
2516	Character Gen. ROM	12.50
7489	64 Bit RAM TTL	3.50
8223	Programmable ROM	7.95

INTEGRATED CIRCUIT SOCKETS

14-Pin, DIP	\$.45
14-Pin, Wire Wrap	.50
14-Pin, Side Mount	1.00
16-Pin, DIP	.50
16-Pin, Wire Wrap	.59

Buy Any 3 Take 10% Discount! TO-5, 8 or 10-Pins.

POLY PAKS

P.O. BOX 942R, LYNNFIELD, MASS. 01940

INTERNATIONAL ELECTRONICS UNLIMITED

NOVEMBER SPECIALS

7453.....7/\$1.00	LM308.....\$.95 ea	LM747.....\$.75 ea
7454.....7/\$1.00	LM723......50 ea	8836......40 ea
7460.....7/\$1.00	LM739.....1.00 ea	9601......95 ea

Sale prices end Nov. 30

TTL

7400 \$.25	7444 \$1.30	7496 \$1.05
7401 .25	7445 1.25	74100 1.40
7402 .25	7446 1.45	74105 .50
7403 .25	7447 1.45	74107 .55
7404 .29	7448 1.50	74121 .65
7405 .27	7450 .29	74122 .55
7406 .55	7451 .32	74123 1.15
7407 .53	7453 .32	74145 1.25
7408 .29	7454 .45	74153 1.45
7409 .29	7455 .32	74154 1.75
7410 .25	7460 .30	74155 1.35
7411 .35	7464 .45	74156 1.50
7413 .95	7465 .45	74157 1.50
7415 .50	7470 .50	74160 1.90
7416 .50	7472 .45	74161 1.65
7417 .50	7473 .55	74162 1.80
7420 .25	7474 .55	74163 1.80
7421 .32	7475 .95	74164 2.95
7422 .32	7476 .55	74165 2.95
7423 .37	7480 .69	74176 .95
7425 .39	7483 1.25	74177 .95
7427 .39	7485 1.20	74180 1.15
7430 .25	7486 .55	74181 4.50
7432 .30	7489 3.25	74182 1.10
7437 .50	7490 1.25	74192 1.65
7438 .55	7491 1.40	74193 1.65
7440 .25	7492 1.05	74195 1.15
7441 1.25	7493 1.05	74197 1.15
7442 1.15	7494 1.10	74199 2.50
7443 1.25	7495 1.05	

Low Power Devices

74L00 .40	74L30 .40	74L78 .80
74L02 .40	74L42 1.75	74L85 1.25
74L03 .40	74L51 .40	74L86 .95
74L04 .40	74L71 .60	74L90 1.75
74L10 .40	74L72 .60	74L93 1.75
74L16 .40	74L73 .80	74L95 1.75
74L20 .40	74L74 .80	74L164 2.95
8000 Series		
8091 .69	8123 1.75	8810 .95
8092 .69	8214 1.95	8812 1.25
8093 .69	8280 .95	8831 1.95
8094 .69	8520 1.45	8836 1.25
8095 .69	8551 1.95	

Linears

LM300 Pos V reg (super 723 V) TO5	\$.95 ea
LM301 Hi performance ampli TO5	.45 ea
LM302 Voltage follower TO5	.95 ea
LM304 Neg Volt regulator TO5	1.25 ea
LM305 Pos Volt regulator TO5	1.25 ea
LM307 Op Amp (super 741) TO5	.45 ea
LM308 Micro power Op Amp TO5	1.25 ea
LM309K 5V 1A power supply reg TO3	1.95 ea
LM309H 5V regulator TO5	1.25 ea
LM310 Volt follower Op Amp TO5	1.45 ea
LM311 Hi perf volt comp TO5	1.25 ea
LM320 -5.2V Neg regulator TO3	1.95 ea
LM320 -12V Neg regulator TO3	1.95 ea
LM320 -15V Neg regulator TO3	1.95 ea
LM380 2 watt audio amplifier Dip	1.75 ea
LM3900 Quad Amplifier Dip	.50 ea
LM709 Op Amp TO5 or Dip	10/\$3.25 .39 ea
LM723 Volt reg. Dip	5/\$3.25 .75 ea
LM741 Comp Op Amp TO5-Dip	10/\$3.95 .45 ea
LM747 Dual 741 Op Amp Dip	4/\$3.50 .95 ea

Phase Locked Loops

NE565 Phase locked loop dip	\$2.95 ea
NE566 Function Gen TO5-mini dip	2.95 ea
NE567 PLL/Tone Gen TO5-mini dip	2.95 ea

Memories (data included)

1101 256 bit RAM MOS (2501)	\$2.50 ea
1103 1024 bit RAM MOS	7.95 ea
7489 64 bit RAM TTL	3.25 ea
8223 Programmable ROM	6.95 ea

LED

MV10B Visible red SUPER SPECIAL	\$.25 ea
MV50 type red emitting	.25 ea 5/\$1.00
MV5020 type Large red	.35 ea 3/\$1.00
ME4 Infra red TO18	.69 ea
MAN 1 The Original	3.95 ea
MAN 3 type	1.95 ea 3 or more 1.49 ea
MAN 4 type	2.75 ea 3 or more 2.50 ea
Data-Lite 707 (MAN 1 repl)	3.25 ea

Opto Isolators

MCA 2-30 Darlington	\$.95 ea
MCD 2 Diodes	1.95 ea
MCT 2 Transistor	1.45 ea

Calculator Chips

5001 LSI (40 pin) Add, subtract, multiply & divide 12 digit	
Data supplied with chip	\$6.95 ea
Data only-Refundable w/purchase	1.00 ea
5002 LSI Similar to 5001 except designed for battery power	
Data supplied with chip	\$8.95 ea
Data only-Refundable w/purchase	1.00 ea
5005 LSI (28 pin) Full four function memory .12 digit display and calc. 7 segment multiplexed output	
Data supplied with chip	\$10.95 ea
Data only-Refundable w/purchase	1.00 ea

Digital Clock . . . on a Chip

MM5311 (28 pin) Any readout 6 digit BCD.	
with spec sheet	\$11.95 ea
MM5312 (24 pin) Any readout 4 digit lpps BCD	\$8.95 ea
MM5314 (24 pin) LED-Incandescent readout 6 dlt.	\$10.95 ea
MM5316 (40 pin) Normal alarm, snooze alarm, sleep timer 12 or 24 hr operation with spec sheet	\$15.95 ea

CMOS

74C00 \$.90	74C73 \$1.70	74C161 \$3.25
74C02 .90	74C74 1.50	74C162 3.25
74C04 1.10	74C76 1.70	74C163 3.25
74C10 .90	74C107 1.50	74C192 3.25
74C20 .90	74C157 2.25	74C195 3.00
74C42 2.15	74C160 3.30	80C97 1.50

4000 Series

CD4001 \$.65	CD4023 \$.65	CD4035 \$.65
CD4011 .65	CD4030 .65	

Test them yourselves and save

MOS Untested		
402 TO5	\$.35	5019 TO5 \$.25
501 TO5	.35	5051 Dip .35
502 TO5	.35	5053 TO5 .25
504 TO5	.35	5054 Dip .35
505 TO5	.55	5055 Dip .35
1402 Dip	.75	5056 Dip .35
1403 Dip	.75	5057 Dip .35
1404 Dip	.75	5060 Dip .35
5006 TO5	.25	5230 Dip 1.00
5013 Dip	.65	5554 Dip 1.00
5016 Dip, TO5	.25	5555 Dip 1.00
5017 Dip, TO5	.75	5556 Dip 1.00

MOS Shift Registers 2500 Series

2502	2506	2509	2510	2511	2518	2519	2521
2522	2524	2525					
Untested seconds.....							4/\$1.00

Grab Bag Specials

15 Assorted TTL's (dips).....	\$1.00/bag
25 Assorted DTL's (dips).....	\$1.00/bag

ON ORDERS OVER \$25.00 DEDUCT 10%

Satisfaction guaranteed. All items except as noted are fully tested. Minimum order \$5.00 prepaid in U.S. and Canada. Calif. residents add sales

tax. Orders filled within three days from receipt. Please add \$.50 per spec sheet for items priced at less than \$1.00 ea.

INTERNATIONAL ELECTRONICS UNLIMITED
 P O Box 1708R
 Monterey, Calif. 93940

Circle 90 on reader service card

CONVERT any television to sensitive big-screen oscilloscope. Only minor changes required. No electronic experience necessary. Illustrated plans \$2.00. **RELCO-A25**, Box 10563, Houston, Tex. 77018

JAPANESE transistors, wholesale prices, free catalog. **WEST PACIFIC ELECTRONICS**, Box 25837, W. Los Angeles, Calif. 90025

TTL IC Semiconductor, Parts discount price list. 10¢. **TOTELEK**, Box 222, Goodyear, Ariz. 85338

NAME brand digital test equipment, discount prices. Free catalog and price list. **SALEN ELECTRONICS**, Box 82, Skokie, Ill. 60076

TUNERS repaired realigned and neutralized by specialists. Uhf or vhf \$9.75, combo \$15.00. Major parts extra. Ship to: **RAINBOW TUNER LABS**, 4158 Greeby St., Phila., Pa. 19135.

HIGH quality components at low prices. **SOLAR ELECTRONIC ENTERPRISES**, Box 778, Edmonton, Alberta, Canada T5J 2L4

AUDIO components, TV's, calculators, test equipment. List of wholesalers \$3. **AUDIOSALES**, Box 39R, Bluepoint, N.Y. 11715

SALE calculator chips CT5005 \$9.95. IC's, LED's clock kits, chips. **ASTRO LABS**, Box 524, Mesa, Arizona 85201

NEW challenge to professional thieves. Patent pending auto 100% theftproof device. Great improvement to steering-column lock. Ready for demonstration. Looking for buyer. Company preferred. **AUTOLAB**, 502 Dryden Road, Ithaca, N.Y. 14850

CANADIAN'S free catalog LED's I.C.'s, transistors, SCR's diodes, parts. **CORONET ELECTRONICS**, 649 Notre Dame St. W., Montreal, Canada

FREE catalog. Reeds, tantalums, transistors, PUT's, LED's, parts. **CHANEY**, Box 15431, Lakewood, Colo. 80215

GIANT 126 page Canadian surplus catalog, \$1.00. **ETCO ELECTRONICS**, Dept. RE, Box 741, Montreal, Canada

DIGITAL electronics! Complete schematics, parts lists, theories—Discrete Component Digital Clock, \$3.00. Increase technical competence, hobby skills—Complete course in Digital Electronics is highly effective, \$10.00. Free literature. **DYNASIGN**, Box 60R2, Wayland, Mass. 01778

MOST VERSATILE Stereo Theatre TRUCK DEVELOPED!

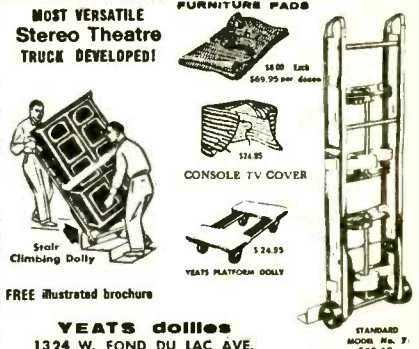

FURNITURE PADS
18 00 Each
\$69.95 per dozen

CONSOLE TV COVER
\$24.95

YEATS PLATFORM DOLLY
STANDARD MODEL No. 7 \$69.50

FREE illustrated brochure

YEATS dollies
1324 W. FOND DU LAC AVE.
MILWAUKEE, WIS. 53205

F.C.C. EXAM MANUAL

PASS FCC EXAMS! Memorize, study—1973 Test Answers! for FCC First and Second class Radio-telephone licenses. Newly revised multiple-choice questions and diagrams cover all areas tested in FCC exams—plus—"Self-Study Ability Test." \$9.95 postpaid.

COMMAND PRODUCTIONS P.O. BOX 26348 — E
 RADIO ENGINEERING DIVISION • SAN FRANCISCO, CALIF. 94126

MORE BARGAINS IN SURPLUS ELECTRO-OPTICS from B & F ENTERPRISES
 Just off the press our Best Catalog yet with 104 Illustrated pages of Surplus Electronics, Optics, and Much More...

NICKEL CADMIUM BATTERIES



- 0.5 ampere hour 1.25 volt sealed button cell 2 for \$1.00
- Vented 4.0 ampere hour cell, plastic case \$2.75
- 24 volt pack, sealed cells, mfg sonotone, size 12" x 1 1/4" x 1 1/4" capacity 0.6 ampere hours \$11.75

CORE MEMORY STACKS



One of our most popular sellouts. Two types available are the 4096 words x 9 bits (36, 864 bits) easily organized as 4096 x 8 bits, and 8192 words x 4 bits (32,768 bits), manufactured by Litton Industries and RCA for Honeywell. Ideal for Minicomputers, some electronics, but no power supplies are included on the card.

- 4096 x 9 Memory \$60.00
- 8192 x 4 Memory \$45.00

LED READOUTS



Popular OPCOA SLA-7, without decimal point. 0.27" numeral height, we formerly sold these at \$4.25, and they sold extremely well. Because of a fortunate purchase we can offer them at a super-low price. Use for clocks, counters, calculators

- SLA-7 Readouts \$2.50

CALCULATOR KEYBOARD

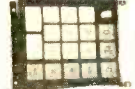

This is a Flex-Key series SK keyboard made for pocket calculators. Only 2.36" x 3.76" x 0.45" thick; Switch matrix for Cal Tex 5001, 5002 or Mostek 5010 or 5012 chips. Smooth, quiet key travel, double short keys, completely sealed, impervious to dust, moisture and even direct liquid spills.

- CK \$8.00
- 10 or more \$6.00

12 VOLT 0.750 AMPERE HOUR SEALED NICKEL CADMIUM BATTERIES

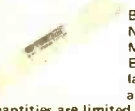

Brand new, manufactured by Gould National. Size: 1" dia. x 9-3/8" L. Manufacturer's list price is \$24.50. Excellent for photo-flash, burglar alarms, etc. Fully guaranteed, available at a fraction of original cost—quantities are limited, won't last long, so order now!

- 12V 0.75 AHSNCB \$9.75

7-SEGMENT DIGITAL DISPLAY — \$1.70 each



Bright blue-green display tube, with numerical display characters. Tube exhibits very fast display speed and easy-to-read characters of .57" H x .36" W, with decimal point. Complete with instructions to make a decade counting unit or a 6-digit clock. Tubes are brand new, bulk packed, and manufactured by Tung-Sol, no. 1705. Sh. Wt. 4 oz.

- 7SDD-1705 \$1.70 each; or 6 for \$8.50, 10 for \$14.00, 100 for \$125.00, 1000 for \$950.00

COLLINS CRYSTAL FILTERS



Anyone who is familiar with super high quality communications receivers is familiar with the Collins filter. 455 Kc center frequency 300 Hz bandwidth. Part number 526 7073 009, type X455-KF 300. Full technical information provided.

- Collins Crystal Filter \$14.75

LOUDSPEAKER SYSTEM COMPONENT SPECIAL!



We have made an excellent purchase of an excess inventory of a local manufacturer's speaker systems, although we are not allowed to mention the mfg's name, the specs should make it self-evident. The woofer is a 12" free-edge (acoustic suspension) unit, with 2" voice coil and a No. 2 magnet. The mid-range is a 5" sealed back speaker and 3-1/2" flare dome tweeter for best high frequency dispersion.

Crossover between woofer & mid-range is by an R-L-C network, while high frequency crossover is by an R-C network. Balance controls are provided for both mid-range and tweeter. Plans for a suitable enclosure are provided. The level controls provide frequency response to suit room acoustics, with realism that will delight even the most critical listener. Response — 25 to 20K + Hz., Power — 40 watts RMS. Impedance — 8 ohms.

- Sh. Wt. 12 lbs.
- LSCS \$36.00
- 2LSCS 2 for \$65.00

TELSA COIL KIT



Here's a truly basic kit for those who like to "roll their own." All the parts for an exciting adventure into high-frequency, high voltage. Add your own metal housing — a small chassis or universal box is ideal.

Tesla coils are patterned after the design of Nikola Tesla (1857-1943) an American electrical genius who built entire cities with energy radiated from such coils — but no luck!

Today's Tesla coils are popular with experimenters and students, and especially for science fair and educational demonstrations. Ours is a high-frequency push-pull oscillator coupled to a television flyback transformer, which steps up an external 12 VDC power supply to many thousand volts.

SPECIAL NOTE: Although current output is relatively low, some hazard is inherent in all high voltage devices. This kit is intended for the experimenter who is mature enough to observe reasonable precaution in its use.

- TESLA COIL KIT \$7.50

DECADE COUNTING UNITS WITH READOUTS

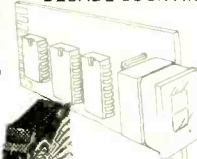

Always one of B & F's most popular items, now revised to include drilled boards, I.C. sockets, and right-angle socket for readout. Arranged so that units can be stacked side by side and straight pieces of wire bussed through for power, ground and reset. Several different units are available as follows:

- 7490 Basic 10 MHz counter. Used in frequency counters and events.
- 74196 Same as 7490 except presettable 50 MHz unit. Used where higher speed and/or presetability is required.
- 74192 Bi-Directional Counter, 32 MHz operation. Has two input lines, one that makes the unit count up, the other down. Uses include timers, where the counter is preset to a number and counts down to zero, monitoring a sequence of events, i.e., keeping track of people in a room by counting up for entries and down for departures.
- 7475 Adds latch capability. Used in counter so displays continue displaying frequency while new frequency is being counted for uninterrupted display. Basic decoder module. Drives basic seven segment display which is included for all modules.
- 7447

NEWEST DCU!

This DCU combines all of the features of our other counting units, that is, high speed counting, up-down operation, storage, and preset. In addition it includes a comparator (7485) and a thumbwheel switch in order to provide comparison and preset capability. With this combination you can do the following:

1. Count up or down at speeds to 33 MegaHertz.
2. Store previous count during new count.
3. Preset to any number, count down (or up) and generate a logic level when count of zero is reached. Stack several units and generate logic level for any count greater than zero.
4. Preset to zero, count up (or down) and generate a logic level for any number greater or equal to the number preset in the thumbwheel switch. Stack several DCU's and generate a logic level showing whether number is greater than, equal to, or less than numbers preset on switches.

- 910 K 7490-7447 Counter \$8.25
- 910 LK 7490-7475-7447 Counter \$9.25
- 911 LK 74196-7475-7447 Counter \$10.25
- 912 K 74192-7447 Counter \$9.25
- 913 K 74192-7475-7447-7485 Universal DCU \$14.50

I.B.M. POWER SUPPLY REGULATOR PARTS!



Like new assembly surplus from the I.B.M. Company contains the following: (6) 150-Watt transistors, (6) heat sinks, (6) 15Ω 5W resistors, 12V, 20 Amp circuit breaker, a 16-ohm 10-Watt resistor, 50-Watt resistor, terminal strip, (2) 16-pin P.C. edge connector for regular cards. An 8000 mfd, 15V computer grade capacitor is also provided. All in a nice mounting — looks as if it could be a neat

unit to make a lab-type power supply. Unit is sold as an assembly, or in parts. Quantity is limited.

- Sh. Wt. 20 lbs. 18MPSRA \$7.50
- 3 for \$20.00 18MPSRA \$20.00/3
- 8 for \$52.00 18MPSRA \$52.00/8

- Heat sinks capable of dissipating 150 watts of power
- Price \$1.00 ea.
- Transistors, 2N441 or 2N442 type, TO-36 case \$1.00 ea.
- Heat sink with transistor \$1.50 ea.
- 4 for \$5.00 \$5.00/4
- Connectors, 2 for \$1.50 \$1.50/2
- Capacitor, \$1.50 \$1.50 ea.

HEWLETT PACKARD SOLID STATE NUMERIC INDICATOR

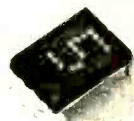

These fantastic L.E.D. indicators have built-in decoder/driver with memory. They use a 4 x 7 dot array for much better readability. They are packaged in a standard Dual-In-Line (DIP) package with built-in contrast filter. Completely DTL TTL compatible. HP part number 5082-7300 (right hand decimal) HP 5082 \$9.75

COMPACT 1mW LASER TUBE



Large manufacturer sells his over-stock tubes to us, all guaranteed to be in perfect condition. Most compact 1mW laser tube (TEM) on the market, only 8-1/2" long, uses a special tapered bore design, unique in the industry. Cavity design, internal hemispherical mirror system with coaxial mounting of all elements, maintain beam alignment and power stability under mechanical stress and changes in temperature. SPECIFICATIONS: red laser, 1mW power, TEM, 632.8nm wavelength, 1.10mm beam diameter, 0.85 mrad divergence, linear polarization, size: 8.5 x 1.75" diameter. These can be useful for alignment systems, measurement systems, and for illumination, etc., in equipment such as levels, transits, ranging, inspection displays, holography, etc. Operation life beyond 10,000 hours. This is not a toy tube, but a laser designed to meet rigid industry standards. List price is over \$200.00 each.

- Sh. Wt. 3 lbs. C1mWLT \$97.50
- 2 for \$180.00 C1mWLT \$180.00/2
- 10 for \$850.00 C1mWLT \$850.00/10
- 100 for \$7500 C1mWLT \$7500.00/100

Portable supply—operates from 12 vdc input. Useful for field experiments with laser. Available only with purchase of tube. Price \$25.00

AIRCRAFT AUTO BOAT QUARTZ CRYSTAL CHRONOMETER

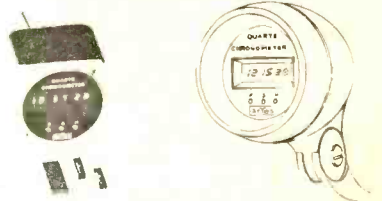

Revolutionary! was the reaction of our customers when they saw our latest kit. Measuring only 2 1/2" x 2 1/2" x 2 3/8", and accurate to 10 seconds a month, this chronometer promises to entirely replace mechanical clocks in cars, boats and airplanes.

Fits into a standard 2 1/2" instrument panel cutout. The displays are bright L.E.D. displays that should last a lifetime. Setting controls are recessed and operate from a pointed object such as a pencil point or paper clip, in order to keep non-authorized hands off. The clock should only have to be reset at very great intervals, or in the event of power loss (i.e., replacing battery in car). The clock is wired so that the timing circuits are always running, but the displays are only lit when the ignition is on, resulting in negligible power drain. The low price is only possible because of a new one chip MOS clock. Operates from 10-14 Volts D.C. An accessory unit which mounts on the back adapts the unit 59 20-28 volts for twin engine aircraft and larger boats using 24 Volts ignition. Know how disgusted you are with the usual car clock? Order this fine unit now for rallying, sports events, navigation, or just to have a fine chronometer that will give you a lifetime of superbly accurate time.

- Quartz Chronometer, Kit Form \$69.50
- Quartz Chronometer, Wired \$99.50
- 24 Volt Adapter \$10.00

New-Style AUTO/BOAT/PLANE QUARTZ CRYSTAL CHRONOMETER

As you can see from the illustration, we have provided a new enclosure for our most popular kit, the ARIES Model AR-720K Quartz Crystal Chronometer. This enclosure can be mounted in many convenient variations, i.e., over or under the dashboard, over the center drive tunnel, or under the roof above the windshield.

- Automotive style quartz crystal chronometer \$75.00
- Same assembled, calibrated, tested \$99.00

Send in an order and get on our special custom customer Mailing List.

CATALOG: Check reader's card or write.

ALL ITEMS (WHERE WEIGHT IS NOT SPECIFIED) POSTAGE PAID IN THE U.S.A.

CHARGES WELCOME!

Phone in charges to 617 531-5774 or 617 532-2323. BankAmericard — Mastercharge, \$10.00 minimum. No C.O.D.'s please.

B.&F. ENTERPRISES Mass. 01960
 Phone (617) 531-5774
 119 Foster Street
 Peabody, Mass. 01960

INSTRUMENT CASES

- Clear Anodized Panel Chassis
 - Scratch-Resist Paint Finish Cover
 - Attached Rubber Feet & Hardware
 - .063 Brushed Aluminum Construction
- VP-11 3.4"x5.5"x2.0" ... \$8.90
 VP-14 8.9"x6.6"x3.4" ... \$9.95
 SP-24 14"x12"x(6.9-3.8)" \$14.95
 16 other off-the-shelf models available.



INSTANT IC BREADBOARD

Used by R & D circuit designers in industry now available to hobbyists at low cost.
 5.5x7.7x.063 G10 glass epoxy board. Predrilled socket holes with solder con sockets.
 Attached rubber feet.
 2oz. etched board, solder plated (MIL-STD 275c) Send \$4.90 plus postage.
 For etched alum. front panel with prepunched holes add \$1.00.
INSTANT INSTRUMENTS INC.
 306 RIVER STREET
 HAVERHILL MA 01830

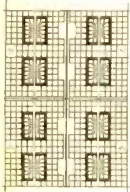

SLA-3 7 segment LED readouts
 .77" numbers. 45 ma/seg. \$9.95

1N4886 40W POWER VARACTOR
 \$4.95

MULTI-TURN TRIM POTS
 Similar to Bourns 3010 style
 3/16" x 5/8" x 1 1/4"
 50, 100, 500, 2000, 5000,
 10,000 and 20,000 ohms.
 \$1.50 3/\$4.00

PRINTED CIRCUIT BOARD
 4 1/2"x6 1/2" double sided fiber-glass board, 1/16" thick, un-etched \$1.60 ea. 5/\$2.50

NIXIE TUBES
 Similar to Raytheon 8754 tubes, with socket & data sheet \$2.25 3/\$6.00

TIS 73 N FET \$1.75
 2N4891 UJT \$1.50
 ER 900 TRIGGER DIODES 4/\$1.00

VERIPAX PC BOARD
 This board is a 1/16" single sided paper epoxy board, 4 1/2"x6 1/2" (standard veripax), DRILLED and ETCHED which will hold up to 21 single 14 pin IC's or 8, 16 or LSI DIP IC's with bussers for power supply connections. It is also etched for a 22 pin connector \$5.25

- FLV 100 Visible LED \$1.59
- ME-4 IR LED \$1.59
- MV5026 Vis. LED \$1.59
- MT-2 PHOTO TRANS. \$1.90
- MCT-2 OPTO-ISOL. \$1.00
- MCD-2 OPTO-ISOL. \$1.00
- Green G.P OSL-16 LED \$1.25
- Red G.P OSL-3 LED \$1.95
- Hi Intensity VIS. RED with reflector \$1.25
- MCA 2-30 photo darlington relay \$1.95

TRIACS

PRV	1A	10A	15A	20A*
100	.40	.70	1.00	1.20
200	.70	1.10	1.50	1.60
300	.90	1.35	1.90	2.00
400	1.10	1.60	2.30	2.40
500	1.50	2.00	2.70	2.80

Terms: FOB Cambridge, Mass.
 Send check or Money Order. Include Postage. Minimum Order \$3.00

Send 20¢ for our latest catalog featuring Transistors and Rectifiers; 325 Elm St., Cambridge, Mass.

Technical Excellence in Electronics.

On our small, friendly campus the emphasis is on living as well as learning. Extra-curricular social activities, student clubs, a student operated radio station, student government, new dormitory and a full sports program help provide a world of your own in which to prepare for tomorrow. Associate Degree in Engineering Electronics. B.S. obtainable. G.I. approved.



VALPARAISO TECHNICAL INSTITUTE
 Dept. C, Yellowstone Trail, Valparaiso, Indiana 46333

BUILD A "SPACE-AGE" TV CAMERA!!

ONLY KNOWN SOLID-STATE CAMERA IN KIT FORM!
 Also available factory assembled. Ideal for experiments, industry, education, etc. High quality performance backed by over seven years of lab and field testing. Fully constructed. Completely self-contained. Connects to any TV set without modification. Easy-to-follow assembly manual. Model XT-1A, Series 2 complete with vidicon \$149.00 PP anywhere in USA. Canada (fast vidicon tube \$116.95pp). Many other kits, parts and plans also available.
 U.S. and Canada: PHONE OR WRITE FOR CATALOG... DIAL 402-967-3771

BOX 453-RE **ATV Research** DAKOTA CITY, NEBR. 68731

TRANSISTOR SPECIALS

Part No.	Type	Specs	Price
2N3137	NPN SI TO-5	.6W 20V .5A 70MHz 500HF	4/\$1.00
MPS3393	NPN SI TO-92	.3W 25V .1A 190	2 4/\$1.00
2N3866	NPN SI TO-5	.5W 30V .1A	Power \$1.75
2N1605	NPN GE TO-5	.15W 24V .1A	14 125 5/\$1.00
2N5324	PNP GE TO-3	60W 250V 10A	20 35 \$1.50
2N1015D	NPN SI TO-82	150W 200V 7.5A	.025 10 \$1.45
2N3584	NPN SI TO-66	35W 250V 2A	10 100 \$1.50
2N3055	NPN SI TO-3	115W 100V 15A	.01 50 \$1.25
2N3772	NPN SI TO-3	150W 60V 30A	.2 30 \$1.35
2N5296	NPN SI TO-220	36W 40V 4A	8 60 \$0.50
2N6109	PNP SI TO-220	36W 40V 4A	8 60 \$0.55
2N4898	PNP SI TO-66	25W 40V 4A	4 46 \$0.60
MJ2251	NPN SI TO-66	10W 225V .5A	10 40 \$0.70
2N3638	PNP SI TO-5	.3W 25V .5A	10 67 5/\$1.00

CAPACITORS

6V 30 UF TANT 5/\$1
 4V 4.7UF TANT. 5/\$1
 20V 10UF ELECT. 5/\$1
 50V 100UF ELECT \$4.40

DATA-LIT 707 Direct replacement for MAN-1 LED readouts \$3.75

MAN-3 LED READOUTS \$2.50

MAN-4 LED READOUTS \$3.25

Full Wave Bridges

PRV	2A	6A
200	.95	1.25
400	1.15	1.50
600	1.35	1.75

1103 1024 bit Ram \$8.00
 NEC 6003 2048 bit RAM \$14.50
 1101 256 bit RAM \$4.00
 8225 64 bit read-write RAM \$4.95

5311—Clock Chip, 6 Digit BCD hold count, Output Strobe \$11.95
 5314—Clock Chip, 6 Digit hold count, Output Strobe ... \$9.95

DECADE COUNTER KIT
 CONSISTING OF:
 1—NIXIE TUBE and SOCKET
 1—7490 1—7475 1—7441
 Special priced at \$5.95

TTL IC SERIES

74100—	.50	7465—	.35
7400—	.28	7472—	.50
7401—	.28	7473—	.60
7402—	.28	7474—	.50
7403—	.28	7475—	1.00
7404—	.33	7476—	.75
7405—	.30	7480—	.70
7406—	.50	7483—	1.25
7408—	.32	7486—	1.50
7410—	.28	7490—	1.50
7411—	.32	7492—	1.30
7412—	.40	7493—	1.30
7413—	.85	7495—	1.30
7416—	.50	74121—	.70
7417—	.50	74123—	1.10
7420—	.28	74125—	1.50
7422—	.32	74126—	1.50
7426—	.35	74151—	1.25
7430—	.28	74157—	1.50
7437—	.60	74164—	2.20
7438—	.55	74165—	2.20
7440—	.28	74176—	1.95
7441—	1.50	74177—	1.95
7442—	1.50	74192—	1.75
7446—	1.50	74193—	1.75
7447—	1.50	74195—	1.25
7448—	1.50	8211—	1.50
7450—	.28	8220—	1.50

Silicon Power Rectifiers

PRV	1A	3A	12A	50A
100	.06	.11	.30	.90
200	.07	.16	.35	1.25
400	.09	.20	.50	1.50
600	.11	.25	.70	1.80
800	.15	.35	.90	2.30
000	.20	.45	1.10	2.75

14 PIN DIP WIRE WRAP SOCKETS \$5.00

ASC II ENCODED TERMINAL KEY BOARDS \$60.00

- LINEAR CIRCUITS**
- PA234 1W audio ampl. \$1.25
 - LM309K 5V IA regulator \$2.25
 - 536 FET input oper amp \$3.25
 - 537 Precision 741 \$2.50
 - 540 70W Power driver \$2.04
 - 560 phase lock loop \$3.25
 - 561 phase lock loop \$3.25
 - 565 phase lock loop \$3.35
 - 567 Tone decoder \$3.25
 - 703 RF-IF amplifier \$1.80
 - Dual 709 \$1.95
 - 709C operational Amp \$1.50
 - 723 Regulator \$1.75
 - 741 operational Amp \$1.50
 - 747 Dual 741 \$1.25
 - TVR 2002 high power 723 \$1.00
 - CA3065 FM/TV amp \$1.35
 - LM 308 oper amp \$1.50
 - 101 oper amp \$1.75
 - 741A oper amp \$1.60
 - 320 —5V reg. \$2.25
 - 320 —15V reg. \$2.25
 - 424 Zero volt switch \$1.25
 - 748 oper amp \$1.95

Silicon Control Rectifiers

PRV	1.5A	6A	10A	70A
100	.40	.50	.60	3.50
200	.60	.70	.80	6.50
400	1.00	1.20	1.30	9.50
600			1.70	11.00

ADVERTISING INDEX

RADIO ELECTRONICS does not assume responsibility for any errors which may appear in the Index below.

READER SERVICE CARD NO.	PAGE
Barta.....	100
Bell & Howell Schools.....	64-67
12 B&K, Division of Dynascan Corp.....	30
69 Brooks Radio & TV Corp.....	97
21 BSR USA Ltd.....	81
1 Castle TV Tuner Service, Inc.....	Cover II
7 Channellock Inc.....	22
72 Chapman Manufacturing Co., Inc.....	98
13 Cleveland Institute of Electronics.....	54-57
CREI, Division of the McGraw-Hill Continuing Education Co.....	36-39
9 Crown International.....	26
14 Delta Products, Inc.....	71
78 Edmund Scientific Co.....	110
65 EICO, Electronic Instrument Co.....	92
26 Electronic Chemical.....	86
76 Electronic Distributors, Inc.....	100
EMC, Electronic Measurements Corp.....	92
63 E & L Instruments Inc.....	100
75 Enterprise Development Corp.....	90
74 Fordham Radio Supply Co.....	99
64 GC Electronics.....	91
67 Grantham School of Electronics.....	95
GTE Sylvania Electronic Components.....	2
GTE Sylvania Electronic Components.....	27
100 Heath Co.....	24-25
100 Heath Co.....	74-77
2 ICS School of Electronics.....	1
73 Indiana Home Study Institute.....	99
94 International Components Corp.....	14
5 International Crystal Mfg. Co.....	16
76 Jensen Tool & Alloys.....	100
4 Jerrold Electronics.....	7
66 Lafayette Electronics.....	93-94
79 Leader.....	Cover III
71 Lectrotech, Inc.....	98
11 Micro-Instrumentation Telemetry Systems, Inc.....	29
29 Midwest HiFi.....	88
C. H. Mitchell Co.....	100
27 Mountain West Alarm Supply Co.....	87
30 National Camera Co.....	88
National Technical Schools.....	18-21
National Radio Institute.....	8-11
10 Olson Electronics.....	28
19 PAIA Electronics.....	81
Panasonic-Parts Division.....	73
18 PTS Electronics, Inc.....	80
20 Quietrole Co.....	81
81 Radio Shack.....	15
RCA Electronic Components Semiconductors.....	85, 87
22 Rectifier Components Corp.....	82
70 Rye Industries.....	98
62 Schober Organ.....	89
61 Security Systems Management School.....	89
6 Sennheiser Electronic Corp.....	17
8 Shure Bros.....	23
17 Southwest Technical Products.....	78
24 Sprague.....	83
Supreme Publications.....	82
25 Tab Books.....	86
Technics by Panasonic.....	Cover IV
16 Telematic.....	78
15 Telvac Instrument Co.....	78
23 Tri-Star Corp.....	83
3 Turner Service Corp.....	5
82 TV Tech. Aids.....	99
68 Ungar, Div. of Eldon Ind., Inc.....	96
83 McMahon's Vingage Radio M. Weinschenker Elec.....	86 89
80 Winegard.....	13
28 Xcelite Inc.....	88
MARKET CENTER	
ATV Research Corp.....	108
84 Babylon Electronics.....	101
91 B.F. Enterprises.....	107, 109
Command Productions.....	106
85 Delta Electronics.....	102
87 Digi-Key.....	102
Instant Instruments Inc.....	102, 108
90 International Electronics Unlimited.....	106
Lakeside Industries.....	102
Lesco Electronics.....	102
Logic Newsletter.....	102
86 Meshna Electronics, John Jr.....	104
88 Polypaks.....	103, 105
Solid State Sales.....	108
Surplus Center.....	104
89 United Sales.....	104
Valparaiso Technical Institute.....	108
Yeats Appliance Dolly Sales Co.....	106

SOLID STATE SALES
 Post Office Box 74D Somerville, Mass. 02143 Tel. (617) 547-4005

MORE BARGAINS IN SURPLUS ELECTRONICS from B & F ENTERPRISES

Just off the press our Best Catalog yet with 104 illustrated pages of surplus Electronics, Optics, and Much More...

DIGITAL CLOCK CHIP

These large scale integrated (LSI) chips eliminate 14 to 20 MSI TTL chips in the design of an electronic clock. Features 12 or 24 hour operation, 6 digits, internal multiplexing, operated on 50 or 60 Hz input, or a schematic is provided for crystal control. Logic gates between the counter allow setting at the rate of one hour digit per second, or, one minute digit per second. A "hold" input allows stopping the chain. The multiplexer samples the outputs of the hours, minutes and seconds counters (in the six digit model), routing this data to a programmable read only memory (ROM), which is programmed to provide BCD and seven segment outputs. All outputs are compatible with bipolar devices, necessitating few external components for the display interface. Only one power supply is required for operation.

- 5314 chip (24 pin plastic) used for 7 segment displays such as LED's, numitrons, minitrons and Sperry displays. Price \$9.95
- 5311 chip (28 pin ceramic) includes BCD output to above for interface to nixies, computer inputs, etc., in addition to 7 segment outputs. Price \$14.95

1/4-Watt RESISTOR ASSORTMENT!!

Brand-new 5% tolerance resistors, individually-bagged 5 to a bag, each bag marked with values. 70 different values, 10 ohms to 10 megohms in a 1: 1.5 : 2.2 : 3.3 : 4.7 : 6.8 : 1 sequence. A complete laboratory supply of resistors at less than 5 cents apiece

Sh. Wt. 2lbs.	1/4WRA	\$15.00
4 bags for \$55.00	1/4WRA	\$55.00/4

KEYBOARDS:



Teletype format ASCII coded keyboard, with parity check line (see fig. A). Coding is by means of a built in diode matrix, which can be modified from ASCII by inserting or removing diodes. Keys are 26 characters, all numbers, plus shift, ctrl, alt, line feed, carriage return, rpt, brk, rub out, here is, and usual typewriter symbols. Mfr controls research and microswitch. Requires +5 volts, uses DTL circuitry, compatible with DTL or TTL. 52 keys, 3 integrated circuits, about 200 diodes. Brand new, guaranteed. 15 pin connector on 10" cable.

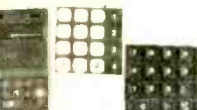

- KB-01 Non-decoded alphanumeric keyboard, Figure "C", single form, SPST contact on each key. \$44.50
- KB-3 Figure "D", calculator keyboard in calculator case, pressure sensitive elastomer contacts, manufactured for Aris. \$24.50
- KB-4 Touch-tone keyboard, Figure "E", manufactured by Chromerics. No electronics included. \$9.50
- KB-5 Desk calculator keyboard, Figure "F", manufactured by Control Research. \$9.00
- KB-6 \$15.75

RT 270A/GRC TRANSCEIVER

This is a prime government surplus item, until recently in scarce supply and selling for hundreds of dollars. Consists of a double conversion FM superhetrodyne receiver and a FM transmitter linked thru a common antenna circuit. Range is 747 to 58.4 MHz continuous. Size is 7-3/8 x 4-3/16 x 12-15/16. Built-in calibrator and heat oscillators permit fast alignment

- RT 270A/GRC New, including 1 MHz crystal \$35.00
- RT 2700A/GRC Used, excellent, less crystal \$20.00
- *** 1 MHz crystal only \$5.00

TRANSISTORIZED FLUORESCENT CAMPING/EMERGENCY LIGHT KIT!

This transistor inverter powered camping and emergency light will provide a bright portable light from a 12-Volt D.C. battery. A cigarette lighter adapter is provided for automotive operation, or the unit may be run from other 12-Volt lantern batteries. The advantages of this unit over more conventional incandescent lamps is the vastly greater light output for equivalent power input and the superior distribution and color of the light. The camping/emergency light is enclosed in a weather-tight plexiglass tube, with the electronics built into the tube. Completion time should be less than two hours, making it a nice evening's project, even for the beginner.

Sh. Wt. 3 lbs.	TFCELK	\$12.50
----------------	--------	---------

CALCULATOR CHIPS

- Chip "A" 12 digit, fixed automatic decimal point, no constant, mfg by mostec or caltex. 40 pin i.c. \$11.75
- Chip "B" 8 digit, floating point, 7 segment output, constant, single 40 pin i.c. mfg by nortec and microsystems international. Price \$19.75

5-VOLT, 5-AMPERE LOGIC SUPPLY

These high-quality supplies originally cost \$118.00 in production quantities. Due to a manufacturer's closeout, we can offer them at less than one-quarter the price. Unit is cooled by a Pamoator fan, is fully adjustable ($\pm 10\%$) and is rated for continuous duty service at full load in an industrial environment. Brand new in original cartons - can be used as a lab or prototype supply. This is a best value in B&F's extensive line of electronic surplus. 5V5A Supply \$34.50

COPPER-CLAD CIRCUIT CARD MATERIAL

Make your own circuits with this card stock. We have fiberglass, epoxy G-10, cloth epoxy, etc., in thicknesses of 1/32", 1/16", and 1/8". Can be used as-is for screen-processed parts, or can be coated with photoresist (available from Kodak and others) for photo process.

	Single-Copper Clad		Double Copper Clad	
Size	1-4	5-9	10-25	10-25
6x12	1.00	.80	.70	1.20 1.00 .75
12x12	1.60	1.40 1.25	2.00	1.75 1.55
12x18	2.30	2.10 1.80	2.75	2.45 2.00

Note: Prices quoted are PER UNIT price (or designated quantity).

6032 INFRA-RED CONVERTER TUBE

With this tube, an appropriate power supply, optics and I.R. light source, one can "see in the dark". Tube converts infrared radiation imaged on front to visible image on back of tube. With it one can see I.R. emitters such as I.R. light emitting diodes, very hot objects. Or see in the dark by using an incandescent light behind a I.R. filter. Full instructions included. Requires 10-20,000 volts to operate.

- 6032 tube only, with data \$7.50
- 6032 tube, with solid state voltage converter 12 volts D.C. to 15 KV instructions \$27.50
- 6032 tube, voltage converter and optics instructions \$47.50

GIANT 2 1/2" NUMERAL "NIXIE" CLOCK KIT

New! For factories, offices, and commercial establishments, and those people who like large displays, characters appear as a bright continuous line which can be read from distances as great as 150 feet. All drive circuits are solid state, and unit employs new custom LSI clock chip. Indicates hour, minutes, and seconds. May be wired for 24 hour or 12 hour operation with a simple jumper change. Kit offered complete with or without case for custom installations. Parts include P.C. board, sockets, solid state components, hardware, resistors, caps, viewing filter, etc.

- Sh. Wt. 15 lbs.
- GNNC/C With Case \$98.50
- GNNC Without Case \$84.50

ULTRA LOW COST DIGITAL CLOCK (STANDARD TIME CHRONOMETER)

Aris/BF has sold over 12,000 digital clocks, to the best of our knowledge more than the combined output of all other manufacturers. Because of our huge purchasing power, and the engineering background gained, we can offer the features listed below. Compare with any other manufacturer and see if they can offer all these features:

- Decorator solid walnut case. A striking addition to even the most luxurious living room. Our sketches just don't do it justice.
- Superb accuracy, seconds per month.
- Choice of 50 or 60 Hz operation, 12 or 24 hour display in hours, minutes, seconds.
- BCD outputs, for auxiliary readouts etc.
- Excellent beginners kit, elaborate step by step instructions (debugged by trial construction by experimenters who have never built a kit before. Only a soldering iron, wire snip and screwdriver needed. Guaranteed success. (Maximum repair charge \$10.00).
- Low-cost Digital Clock Kit \$47.50

SUPER QUALITY I.C. SOCKETS

Sockets made by T.I. and Cinch. All are low-profile, compact types.

- 14 Pin Dip Solder Tale Sockets 3 for \$1.25 16 for \$5.00
- 16 Pin Dip Solder Tale Sockets 2 for \$1.00 13 for \$5.00
- 14 Pin Dip Gold Wire Wrap Socket 2 for \$1.25 10 for \$5.00
- 16 Pin Dip Gold Wire Wrap Socket 2 for \$1.50 8 for \$5.00
- 10 Pin to 5 Gold Sockets (Cinch) 2 for \$1.00 13 for \$5.00

Now available 24, 28, & 40 Pin sockets Only \$1.00 ea.

RADIATION SURVEY METER

At this giveaway price, no one should be without one of these. In the event of a reactor explosion or atomic attack it could save your life. "CD" type Radiation Meter in good condition with carrying straps and instruction manual. Picture is of a typical unit in bright plastic waterproof case. Counter gives readings from 0.01 γ /hr to 50 γ /hr. Batteries required are one (NEDA 13) D cell and one (NEDA 215) 22 $\frac{1}{2}$ v hearing aid battery, not supplied. Will last approx. 400 hrs. of intermittent operation on one set of batteries. Last time we offered these we were sold out in a short time. All units are clean, like new. Untested.

Sh. wt. 3 lbs. GCCDT \$7.00

COMPUTER GRADE ELECTROLYTIC CAPACITORS

These brand new capacitors are in great demand for IC logic circuit filters, power supplies and energy storage networks. Some of them are big enough to take out the noise in the most stubborn cases. Capacitance (first number) is given in MF.

COMPUTER GRADE CAPS - ALL NEW

Wt. (lb)	Cap (mfd)	WVDC	Order No	Price (ea)
1	1500	50	GE1550	.75
1	1300	50	SP1350	.75
3	3000	250	MA3025	3.50
2	17000	30	GE17030	2.00
2	23000	20	GE2320	2.00
3	60000	20	GE60020	3.50
3	140000	6	SP14006	3.50
1	6000	40	GE6040	2.00
2	21500	40	GI21540	3.00
1	10800	20	GI10820	1.75
1	150	250	SA1525	1.00
3	1000	450	SP10045	2.50
1	6000	10	PA6010	.75
1/2	75	350	MA753	.60
1.5	3750	75	SA3775	1.50
1	500	200	CA520	1.25
1	7400	10	CA7410	1.25
1	15000	10	CA1510	1.50

COMPUTER GRADE CAPS - REMOVED FROM EQUIPMENT

Cap.	WVDC	Order No	Price
250	330	CC2533	1.00
300	275	CC3027	1.00
750	165	CC7516	1.00
800	99	CC8099	1.00
900	165	CC9016	1.25
2300	23	CC2323	1.00
3500	62.5	CC3552	1.25
7000	16.5	CC7016	1.25
10000	11	CC1011	1.25

All caps 12 for the price of 10.

NEW - COSMOS INTEGRATED CIRCUIT

Said to be the "New Wave" in integrated circuits of the future. Ultra low power drain (microwatts)

- 4000AE Dual 3 Input Nor & Inv \$.99
- 4001AE Quad 2 Input Nor \$.99
- 4002AE Dual 4 Input Nor \$.99
- 4006AE 18 Stage Static Shift Register \$4.99
- 4007AE Dual Complementary Pair & Inv \$.99
- 4009AE Hex Buffer, Inverting \$2.19
- 4010AE Hex Buffer, Non Inverting \$2.19
- 4011AE Quad 2 Input Nand \$.99
- 4012AE Dual 4 Input Nand \$.99
- 4014AE 8 Stage Static Shift Register \$5.99
- 4017AE Decade Counter W/Decoder \$5.99
- 4020AE 14 Stage Binary Ripple Counter \$5.99

Send in an order and get on our special customer Mailing List.

CATALOG: Check reader's card or write.
ALL ITEMS (WHERE WEIGHT IS NOT SPECIFIED) POSTAGE PAID IN THE U.S.A.
CHARGES WELCOME!

Phone in charges to 617 531-5774 or 617 532-2323. BankAmericard - Mastercharge. \$10.00 minimum. No C.O.D.'s please.

B & F ENTERPRISES Mass. 01960
Phone (617) 531-5774
119 Foster Street
Peabody, Mass. 01960

Circle 109 on reader service card

LIVE IN THE WORLD OF TOMORROW...TODAY!

A BETTER LIFE STARTS HERE

3-CHANNEL COLOR ORGAN KIT

Easy to build low-cost kit needs no technical knowledge. Completed unit has 3 bands of audio frequencies to modulate 3 independent strings of colored lamps (i.e. "lows"-reds, "middles"-greens, "highs"-blues. Just connect hi-fi, radio, power lamp etc. & plug ea. lamp string into own channel (max. 300w ea.). Kit features 3 neon indicators, color intensity controls, controlled individ SCR circuits; isolation transformer; custom plastic housing; instr.



Stock No. 41,831EH\$17.50 Ppd.

KNOW YOUR ALPHA FROM THETA!

For greater relaxation, concentration, listen to your Alpha-Theta brainwaves. Ultra-sensitive electrode headband slips on/off in seconds—eliminates need for messy creams, etc. Atch'd to amplifier, filters brainwaves, signals beep for ea. Alpha or Theta wave passed. Monitoring button simulates Alpha sound audio & visual (L.E.D.) feedback. Reliable, easy-to-use unit—comparable to costlier models. Completely safe. Comprehen. instr. bkit.



No. 1635EH (8x3x4"; 24 oz.) .. \$124.50 Ppd.
Stock No. 71,809EH. (Low Cost "Starter" Unit)\$49.95 Ppd.

130 EXPERIMENTS IN OPTICS . . .



and photography! Optix® Experiments Kit is a complete optical & photography lab for 130 exciting experiments. Lets you recreate the periscope, telescope, microscope, kaleidoscope! . . . Build a 35mm reflex camera with interchangeable lens system! Make, develop photographic film! Enjoy the fun and fascination of having your own optics lab. Fully illustrated 112-pg. manual, 8½"x11", clearly explains usage of this stimulating kit's 114 precision engineered components.



Stock No. 71,646EH\$22.50 Ppd.

(And our FREE CATALOG is packed with exciting and unusual ecological & physical science items—plus 4,500 finds for fun, study or profit . . . for every member of the family.) Great for unusual christmas gifts!

ELECTRONIC CALCULATOR—\$79.95!

Terrific buy, reduced from \$199.50! Top quality American made with big machine capabilities. Adds, subtracts, multiplies, divides, does mixed calculations—silently in milliseconds! 8-digit entry, readout; floating decimal; +/- change key; zero suppression; automatic constant; error correction; recall key. Easily operated in home or office. 110-120v AC. 6-1/2X9X2". 3 lb. 6-month guarantee. Instructions.



Stock No. 78,006EH\$79.95 Ppd.
No. 78,007EH (6-oz. PORTABLE)\$89.95 Ppd.
No. 78,008EH (ECONOMY MODEL—NO MEMORY)\$59.95 Ppd.

AUTHENTIC ACUPUNCTURE MODEL

Learn first-hand about Asiatic needle probing from exact duplicate of models used in Red China. 10½" free-standing model clearly shows 12 all-important meridian lines and approx 500 specific points an acupuncturist must learn to pierce. Precise enough to serve as teaching aid for doctors, teachers & medical students. Fully illustr instructive 12-page bkit. See why this 5000 yr. old healing & pain removal method has had such impact on Amer. medicine. Polyethylene (rubberized).



Stock No. 71,778EH\$12.00 Ppd.

3" ASTRONOMICAL TELESCOPE



See moon shots, orbits, stars, phases of Venus, planets close up. 60 to 180 power. New Improved, aluminized and overcoated 3" diameter f/10 primary mirror, ventilated cell. Equatorial mount with locks on both axes. Equipped with 60x eyepiece and mounted Barlow lens. 3x finder telescope, hardwood tripod. Included FREE: "STAR CHART", "HOW TO USE YOUR TELESCOPE" book.

Stock No. 85,050EH\$34.95 Ppd.
DELUXE 3" REFLECTOR TELESCOPE
Stock No. 80,162EH\$62.50 Ppd.
4¼" REFLECTOR TELESCOPE (45x to 270x)
Stock No. 85,105EH\$110.00 FOB
4¼" REFLECTOR TELESCOPE WITH CLOCK DRIVE Stock No. 85,107EH \$145.00 FOB
6" REFLECTOR TELESCOPE Stock No. 85,187EH\$215.00 FOB
6" REFLECTOR W/(ELECTRIC) CLOCK DRIVE No. 85,086EH\$249.50 FOB

MAIL COUPON FOR GIANT FREE CATALOG!

164 PAGES • MORE THAN 4,500 UNUSUAL BARGAINS!

Completely new '74 Catalog. Packed with huge selection of telescopes, microscopes, binoculars, magnets, magnifiers, prisms, photo components, ecology and Unique Lighting items, parts, kits, accessories — many hard-to-get surplus bargains. 100's of charts, illustrations. For hobbyists, experimenters, schools, industry.

EDMUND SCIENTIFIC CO.

300 Edscorp Building, Barrington, N. J. 08007

Please rush Free Giant Catalog "EH"

Name _____

Address _____

City _____

State _____ Zip _____

COMPLETE & MAIL WITH CHECK OR M.O.

EDMUND SCIENTIFIC CO.

300 Edscorp Building, Barrington, N.J. 08007

How Many	Stock No.	Description	Price Each	Total

PLEASE SEND GIANT FREE CATALOG "EH" MERCHANDISE TOTAL \$

ADD HANDLING CHARGE—\$1.00 ON ORDERS UNDER \$5.00; 50¢ ON ORDERS OVER \$5.00

TOTAL \$ _____

I enclose check

money order for \$ _____

NAME _____

ADDRESS _____

CITY _____ STATE _____ ZIP _____



Circle 78 on reader service card

3" DUAL TRACE, DUAL CHANNEL SCOPE.

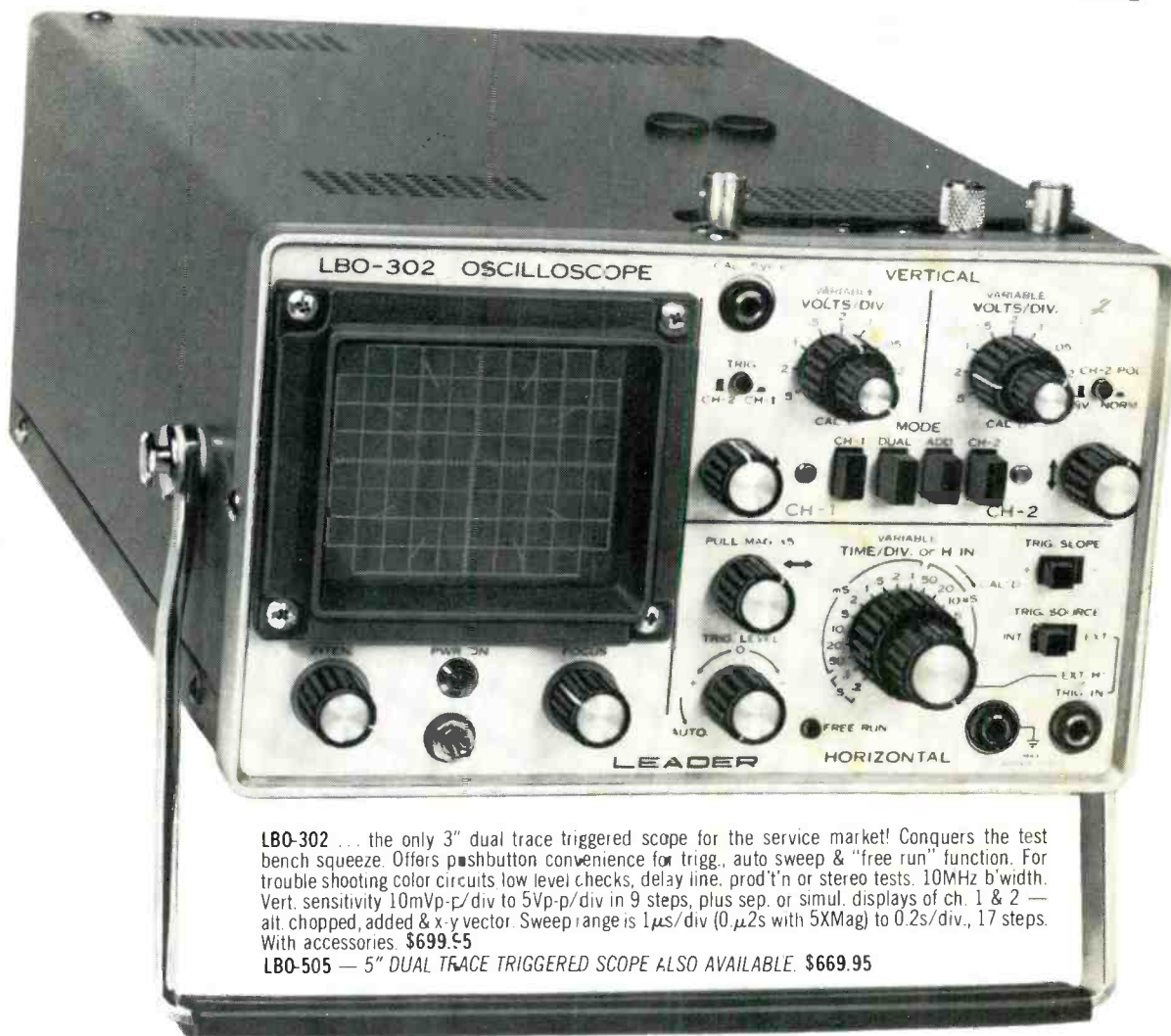

LBO-302 ... the only 3" dual trace triggered scope for the service market! Conquers the test bench squeeze. Offers pushbutton convenience for trigg., auto sweep & "free run" function. For trouble shooting color circuits low level checks, delay line, prod'n or stereo tests. 10MHz b'width. Vert. sensitivity 10mVp-p/div to 5Vp-p/div in 9 steps, plus sep. or simul. displays of ch. 1 & 2 — alt. chopped, added & x-y vector. Sweep range is 1 μ s/div (0.1 μ s with 5XMag) to 0.2s/div., 17 steps. With accessories. \$699.95

LBO-505 — 5" DUAL TRACE TRIGGERED SCOPE ALSO AVAILABLE. \$669.95

LEADER, NATURALLY.

"Put us to the test"

LEADER INSTRUMENTS CORP.

151 Dupont Street Plainview, L.I., N.Y. 11803 (516) 822-9300

Circle 79 on reader service card

The Technics SA-5400X. 4-amplifier 4-channel and 4-amplifier 2-channel.

Technics doesn't force you to choose between 2-channel or 4-channel. We give you both in one unit. The SA-5400X.

It's a very impressive 4-channel receiver. Each of its 4 amplifiers delivers 11 watts RMS, 8 Ω , each channel driven. And its full discrete capabilities include jacks for a CD-4 demodulator. Plus jacks for both 4-channel and 2-channel tape sources. And two tape monitor circuits.

There are also two different matrix decoding circuits that can handle all the popular matrix methods.

The SA-5400X is a great 2-channel receiver, too. Because it has Balanced Transformerless (BTL) circuitry. Our special way of strapping the front and rear amplifiers in tandem for 4-amplifier 2-channel. Which more than doubles the power per channel in stereo. Producing 25 watts RMS per channel (each channel driven) at 8 Ω .

The amplifiers all have direct-coupled circuitry which vastly improves their low-

frequency performance and power bandwidth. And a special phono-equalizer circuit so you can use virtually any kind of phono cartridge efficiently.

There's also a very potent FM section that boasts sensitivity of 2.0 μ v (IHF). With a 4-pole MOS FET and IF amplifiers whose ceramic filters yield 65 dB selectivity.

We knew you'd have a hard time trying to make up your mind about which kind of receiver to buy. So we put both 2-channel and 4-channel in one easy-to-afford unit.

The SA-5400X. The concept is simple. The execution is precise. The performance is outstanding. The name is Technics.

200 PARK AVE., NEW YORK, N.Y. 10017
FOR YOUR NEAREST AUTHORIZED
TECHNICS DEALER, CALL TOLL FREE
800 447-4700. IN ILLINOIS, 800 322-4400.

Technics

by Panasonic

